

Contents

1 : General Information

100 : Service Information

100-00 : General Information

Description and Operation

About This Manual

Application and Use of Specifications

General Service Information

Health and Safety Precautions

How To Use This Manual

Important Safety Instructions

Road/Roller Testing

Solvents, Sealants and Adhesives

Standard Workshop Practices

100-01 : Identification Codes

Description and Operation

Identification Codes

100-02 : Jacking and Lifting

Description and Operation

Jacking

Lifting

100-04 : Noise, Vibration and Harshness

General Procedures

Exhaust System Neutralizing

Description and Operation

Noise, Vibration and Harshness (NVH)

Diagnosis and Testing

Noise, Vibration and Harshness (NVH)

2 : Chassis

204 : Suspension

204-00 : Suspension System - General Information

Specifications

Specifications

General Procedures

Front Toe Adjustment (57.65.01)

Rear Toe Adjustment (57.65.08)

Wheel Bearing Inspection

Description and Operation

Wheel Alignment Angles

Diagnosis and Testing

Suspension System

204-01 : Front Suspension

Specifications

Specifications

Description and Operation

Front Suspension

Diagnosis and Testing

Front Suspension

Removal and Installation

Lower Arm (60.35.02)
Shock Absorber and Spring Assembly (60.30.02)
Front Stabilizer Bar (60.10.01)
Front Stabilizer Bar Bushing (60.10.04)
Front Wheel Bearing and Wheel Hub (60.25.03)
Wheel Knuckle (60.25.23)
Assembly & Disassembly
Shock Absorber and Spring Assembly (60.30.21)

204-02 : Rear Suspension

Specifications
Specifications
Description and Operation
Rear Suspension
Diagnosis and Testing
Rear Suspension
Removal and Installation
Damper
Front Lower Arm - 4-Door (64.35.51)
Front Lower Arm - Wagon (64.35.51)
Rear Lower Arm (64.35.52)
Spring (64.20.01)
Rear Stabilizer Bar (64.35.08)
Rear Stabilizer Bar Link (64.35.24)
Upper Arm (64.25.31)
Wheel Hub (64.15.14)
Wheel Knuckle (64.15.22)
Wheel Knuckle Front Bushing (64.15.28)
Wheel Knuckle Rear Bushing (64.15.30)

204-04 : Wheels and Tires

Specifications
Specifications
Description and Operation
Safety Precautions
Wheels and Tires
Diagnosis and Testing
Wheels and Tires
Removal and Installation
Tire Low Pressure Sensor - VIN Range: J28493->V99999
Tire Pressure Monitoring System (TPMS) Front Antenna - VIN Range: J28493->V99999
Tire Pressure Monitoring System (TPMS) Main Antenna - VIN Range: J28493->V99999
Tire Pressure Monitoring System (TPMS) Module - VIN Range: J28493->V99999
Tire Pressure Monitoring System (TPMS) Rear Antenna - VIN Range: J28493->V99999
Wheel and Tire (74.20.05)

205 : Driveline

205-00 : Driveline System - General Information

Description and Operation
Driveline System
Diagnosis and Testing
Driveline System

205-01 : Driveshaft

Specifications
Specifications
General Procedures
Driveshaft Runout and Balancing
Description and Operation
Driveshaft
Diagnosis and Testing

Driveshaft

Removal and Installation

Driveshaft (47.15.01)

205-02 : Rear Drive Axle/Differential

Specifications

Specifications

Description and Operation

Rear Drive Axle and Differential

Diagnosis and Testing

Rear Drive Axle and Differential

Removal and Installation

Axle Assembly (51.25.13)

In Vehicle Repair

Axle Shaft Seal (51.20.04)

Drive Pinion Flange

Drive Pinion Seal (51.20.01)

205-04 : Front Drive Halfshafts

Specifications

Specifications

Description and Operation

Front Drive Halfshafts

Removal and Installation

Front Halfshaft LH (47.10.15)

Front Halfshaft RH - 2.0L/2.5L/3.0L (47.10.16)

Front Halfshaft RH - 2.0L Diesel/2.2L Diesel (47.10.16)

Inner Constant Velocity (CV) Joint Boot (47.10.18)

Intermediate Shaft

Outer Constant Velocity (CV) Joint Boot (47.10.19)

205-05 : Rear Drive Halfshafts

Specifications

Specifications

Description and Operation

Rear Drive Halfshafts

Diagnosis and Testing

Rear Drive Halfshafts

Removal and Installation

Rear Halfshaft (47.10.13)

Outer Constant Velocity (CV) Joint Boot (47.10.32)

206 : Brake System

206-00 : Brake System - General Information

Specifications

Specifications

General Procedures

Brake Disc Runout Check

Brake System Bleeding (70.25.03)

Description and Operation

Brake System

Diagnosis and Testing

Brake System

206-03 : Front Disc Brake

Specifications

Specifications

Description and Operation

Front Disc Brake

Diagnosis and Testing

Front Disc Brake

Removal and Installation
Brake Caliper (70.55.02)
Brake Disc (70.10.10)
Brake Pads (70.40.02)

206-04 : Rear Disc Brake

Specifications
Specifications
Description and Operation
Rear Disc Brake
Diagnosis and Testing
Rear Disc Brake
Removal and Installation
Brake Caliper (70.55.03)
Brake Disc (70.10.11)
Brake Disc Shield (70.10.19)
Brake Pads (70.40.03)

206-05 : Parking Brake and Actuation

Specifications
Specifications
General Procedures
Parking Brake Cable Adjustment - Vehicles With: Manually Adjusted Parking Brake, VIN
Range: D55322->E24053 (70.35.10)
Parking Brake Cable Adjustment - Vehicles With: Manually Adjusted Parking Brake, VIN
Range: E24054->V99999 (70.35.10)
Description and Operation
Parking Brake
Diagnosis and Testing
Parking Brake
Removal and Installation
Parking Brake Cable - Vehicles With: Manually Adjusted Parking Brake (70.35.29)
Parking Brake Cable - Vehicles With: Self-Adjusting Parking Brake (70.35.29)
Parking Brake Control - Vehicles With: Manually Adjusted Parking Brake (70.35.08)
Parking Brake Control - Vehicles With: Self-Adjusting Parking Brake (70.35.08)

206-06 : Hydraulic Brake Actuation

Specifications
Specifications
Description and Operation
Hydraulic Brake Actuation
Diagnosis and Testing
Hydraulic Brake Actuation
Removal and Installation
Brake Fluid Reservoir (70.30.16)
Brake Master Cylinder (70.30.08)
Brake Pedal and Bracket (70.35.03)
Brake Pedal Cross-Shaft

206-07 : Power Brake Actuation

Specifications
Specifications
Description and Operation
Brake Booster
Diagnosis and Testing
Power Brake System
Removal and Installation
Brake Booster - LHD (70.50.17)
Brake Booster - RHD (70.50.17)
Brake Vacuum Pump - 2.0L
Brake Vacuum Pump - 2.0L Diesel/2.2L Diesel

206-09 : Anti-Lock Control - Stability Assist

Specifications

Specifications

Description and Operation

Anti-Lock Control - Stability Assist

Diagnosis and Testing

Anti-Lock Control - Stability Assist - VIN Range: C00344->J12991

Anti-Lock Control - Stability Assist - VIN Range: J12992->V99999

Removal and Installation

Anti-Lock Brake System (ABS) Module - VIN Range: C00001->J12991 (70.60.02)

Front Wheel Speed Sensor (70.60.03)

Hydraulic Control Unit (HCU) - VIN Range: C00001->J12991 (70.60.18)

Hydraulic Control Unit (HCU) - VIN Range: J12992->V99999 (70.60.18)

Rear Wheel Speed Sensor (70.60.04)

Stability Assist Module

Steering Wheel Rotation Sensor (86.56.58)

Yaw Rate Sensor - 2.0L/2.5L/3.0L/2.0L Diesel (86.56.57)

Yaw Rate Sensor - 2.2L Diesel (86.56.57)

211 : Steering System

211-00 : Steering System - General Information

Specifications

Specifications

General Procedures

Power Steering System Filling

Power Steering System Flushing (57.15.08)

Description and Operation

Steering System

Diagnosis and Testing

Steering System

211-02 : Power Steering

General Procedures

Start Up Procedure After Power Steering Pump/Gear Overhaul

Description and Operation

Power Steering

Diagnosis and Testing

Power Steering

Removal and Installation

Power Steering Control Valve Actuator - 2.5L/3.0L (57.10.32)

Power Steering Fluid Cooler - 2.0L Diesel (57.15.11)

Power Steering Fluid Cooler - 2.2L Diesel (57.15.11)

Power Steering Fluid Reservoir (57.15.08)

Power Steering Pump - 2.0L/2.5L/3.0L (57.20.14)

Power Steering Pump - 2.0L Diesel/2.2L Diesel (57.20.14)

Steering Gear - 2.0L Diesel/2.2L Diesel (57.10.01)

Steering Gear - 2.0L/2.5L/3.0L (57.10.01)

211-03 : Steering Linkage

Specifications

Specifications

Description and Operation

Steering Linkage

Diagnosis and Testing

Steering Linkage

Removal and Installation

Steering Gear Boot (57.10.29)

Tie Rod End (57.55.02)

211-04 : Steering Column

Specifications

Specifications

Description and Operation

Steering Column

Diagnosis and Testing

Steering Column

Removal and Installation

Ignition Switch Lock Cylinder (57.40.29)

Steering Column (57.40.01)

Steering Column Coupling

Steering Wheel (57.60.01)

211-05 : Steering Column Switches

Description and Operation

Steering Column Switches

Diagnosis and Testing

Steering Column Switches

Removal and Installation

Steering Column Multifunction Switch LH (86.65.78)

Steering Column Multifunction Switch RH (86.65.41)

3 : Powertrain

303 : Engine

303-00 : Engine System - General Information

Technical Data

Description and Operation

Diagnosis and Testing

General Procedures

Bearing Inspection

Camshaft Bearing Journal Clearance

Camshaft Bearing Journal Diameter

Camshaft End Play

Camshaft Lobe Lift

Camshaft Surface Inspection

Connecting Rod Cleaning

Connecting Rod Large End Bore

Crankshaft End Play

Crankshaft Main Bearing Journal Clearance

Crankshaft Main Bearing Journal Diameter

Cylinder Block Distortion

Cylinder Bore Out-of-Round

Cylinder Head Distortion

Exhaust Manifold Cleaning and Inspection

Flywheel Inspection

Piston Diameter

Piston Inspection

Piston Pin Diameter

Piston Pin to Bore Diameter

Piston Ring End Gap

Piston Ring-to-Groove Clearance

Valve Seat Inspection

Valve Spring Free Length

Valve Stem Diameter

303-01A : Engine - 2.0L/2.5L/3.0L

Specifications

Specifications

General Procedures

Valve Clearance Adjustment (12.29.48)

Valve Clearance Check (12.29.47)

Description and Operation

Engine

Diagnosis and Testing

Engine

Removal

Engine - Vehicles With: Manual Transaxle (12.41.01)

Engine - Vehicles With: Automatic Transaxle (12.41.01)

Installation

Engine - Vehicles With: Manual Transaxle (12.41.01)

Engine - Vehicles With: Automatic Transaxle (12.41.01)

In Vehicle Repair

Camshafts LH (12.13.19)

Crankshaft Front Seal (12.21.14)

Crankshaft Pulley (12.21.09)

Crankshaft Rear Seal (12.21.20)

Cylinder Head LH (12.29.02)

Engine Front Cover (12.65.01)

Engine Front Mount (12.45.01)

Exhaust Manifold LH (30.15.55)

Flexplate (12.53.13)

Exhaust Manifold RH (30.15.56)

Flywheel (12.53.07)

Intake Manifold (30.15.01)

Lower Intake Manifold (30.15.61)

Oil Cooler (12.60.68)

Oil Pan (12.60.44)

Oil Pressure Sender

Oil Pump (12.60.26)

Timing Drive Components (12.65.13)

Valve Cover LH (12.29.43)

Valve Cover RH (12.29.44)

Disassembly

Engine

Disassembly/Assembly of subassemblies

Cylinder Head (12.29.22)

Piston (12.17.02)

Assembly

Engine

303-01B : Engine - 2.0L Diesel/2.2L Diesel

Specifications

Specifications

Description and Operation

Engine

Removal

Engine - 2.0L Diesel (12.41.01)

Engine - 2.2L Diesel (12.41.01)

Installation

Engine - 2.0L Diesel (12.41.01)

Engine - 2.2L Diesel (12.41.01)

In Vehicle Repair

Crankshaft Front Seal (12.21.14)

Crankshaft Rear Seal (12.21.20)

Engine Front Cover (12.65.01)

Engine Front Mount (12.45.01)

Flexplate (12.53.13)

Flywheel (12.53.07)

Intake Manifold (30.15.01)

Oil Pan (12.60.44)

Timing Chain

Valve Cover

Disassembly

Engine

Assembly

Engine

303-03A : Engine Cooling - 2.0L/2.5L/3.0L

Specifications

Specifications

General Procedures

Cooling System Backflushing

Cooling System Draining, Filling and Bleeding

Cooling System Draining and Vacuum Filling

Cooling System Flushing

Description and Operation

Engine Cooling

Diagnosis and Testing

Engine Cooling

Removal and Installation

Block Heater (86.62.18)

Coolant Expansion Tank (26.15.01)

Cooling Fan Module (26.25.38)

Cooling Fan Motor (26.25.24)

Cooling Fan Motor and Shroud (26.25.25)

Cooling Module (26.40.16)

Radiator (26.40.01)

Thermostat (26.45.07)

Water Pump (26.50.01)

Water Pump Housing (26.50.07)

303-03B : Engine Cooling - 2.0L Diesel/2.2L Diesel

Specifications

Specifications

General Procedures

Cooling System Draining, Filling and Bleeding

Cooling System Draining and Vacuum Filling

Description and Operation

Engine Cooling

Removal and Installation

Cooling Fan Motor and Shroud (26.25.25)

Cooling Module (26.40.16)

Radiator (26.40.01)

Water Pump (26.50.01)

303-04A : Fuel Charging and Controls - 2.0L/2.5L/3.0L

Specifications

Specifications

Description and Operation

Fuel Charging and Controls

Diagnosis and Testing

Fuel Charging and Controls - 2.0L

Fuel Charging and Controls - 2.5L/3.0L, VIN Range: E96603->J28492

Fuel Charging and Controls - 2.5L/3.0L, VIN Range: J28493->V99999

Removal and Installation

Fuel Charging Wiring Harness (86.70.22)

Fuel Injection Supply Manifold (19.60.13)

Fuel Injectors (18.10.02)

Fuel Pulse Damper - 2.5L/3.0L (18.30.98)

Throttle Body (19.70.04)

303-04B : Fuel Charging and Controls - 2.0L Diesel/2.2L Diesel

Specifications

Specifications

General Procedures

Fuel Injection Component Cleaning

Description and Operation

Fuel Charging and Controls

Diagnosis and Testing

Fuel Charging and Controls

Removal and Installation

Fuel Injection Pump

Fuel Injection Supply Manifold (19.60.13)

Fuel Injector (18.10.01)

Fuel Metering Valve

Fuel Return Line Venturi

303-04C : Fuel Charging and Controls - Turbocharger

Specifications

Specifications

Description and Operation

Turbocharger

Diagnosis and Testing

Turbocharger

Removal and Installation

Turbocharger

303-05 : Accessory Drive

Specifications

Specifications

Description and Operation

Accessory Drive

Diagnosis and Testing

Accessory Drive

Removal and Installation

Accessory Drive Belt - 2.0L Diesel/2.2L Diesel (12.10.40)

Accessory Drive Belt - 2.0L/2.5L/3.0L (12.10.40)

Accessory Drive Belt Tensioner - 2.0L Diesel/2.2L Diesel (12.10.41)

Accessory Drive Belt Tensioner - 2.0L/2.5L/3.0L (12.10.41)

Power Steering Pump Belt - 2.0L Diesel/2.2L Diesel

Power Steering Pump Belt Tensioner - 2.0L Diesel/2.2L Diesel

Water Pump Belt - 2.0L/2.5L/3.0L (12.10.44)

Water Pump Belt Tensioner - 2.0L/2.5L/3.0L (12.10.45)

303-06 : Starting System

Specifications

Specifications

Description and Operation

Starting System

Diagnosis and Testing

Starting System - 2.0L

Starting System - 2.5L/3.0L

Removal and Installation

Starter Motor - 2.0L Diesel (86.60.01)

Starter Motor - 2.2L Diesel (86.60.01)

Starter Motor - 2.0L/2.5L/3.0L (86.60.01)

303-07A : Engine Ignition - 2.0L/2.5L/3.0L

Specifications

Specifications

Description and Operation

Engine Ignition

Diagnosis and Testing

Engine Ignition - 2.0L

Engine Ignition - 2.5L/3.0L

Removal and Installation

Ignition Coil-On-Plug LH (18.20.44)

Ignition Coil-On-Plug RH (18.20.43)

303-07B : Glow Plug System

Specifications

Specifications

Description and Operation

Glow Plug System

Diagnosis and Testing

Glow Plug System

Removal and Installation

Glow Plugs

303-08 : Engine Emission Control - 2.0L Diesel/2.2L Diesel

Specifications

Specifications

Description and Operation

Engine Emission Control

Diagnosis and Testing

Engine Emission Control

Removal and Installation

Exhaust Gas Recirculation (EGR) Cooler

Exhaust Gas Recirculation (EGR) Cooler to EGR Valve Tube

Exhaust Gas Recirculation (EGR) Valve (17.45.01)

303-12A : Intake Air Distribution and Filtering - 2.0L/2.5L/3.0L

Description and Operation

Intake Air Distribution and Filtering

Diagnosis and Testing

Intake Air Distribution and Filtering

Removal and Installation

Air Cleaner (19.10.05)

Air Cleaner Element (19.10.08)

Air Cleaner Outlet Pipe (19.10.31)

303-12B: Intake Air Distribution and Filtering - 2.2L Duratorq-TDCi (110kW/150PS) - Puma/2.0L Duratorq-TDCi

Specification

Description and Operation

Intake Air Distribution and Filtering

Diagnosis and Testing

Intake Air Distribution and Filtering

Removal and Installation

Air Cleaner

Air Cleaner Element

Air Cleaner Outlet Pipe

Charge Air Cooler - 2.0L Duratorq-TDCi

Charge Air Cooler - 2.2L Duratorq-TDCi (110kW/150PS) - Puma

303-13: Evaporative Emissions

Specification

Description and Operation

Evaporative Emissions

Diagnosis and Testing

Evaporative Emissions - 2.0L NA V6 - AJV6

Evaporative Emissions - 2.5L NA V6 - AJV6/3.0L NA V6 - AJ27

Removal and Installation

Evaporative Emission Canister - 2.0L NA V6 - AJV6

Evaporative Emission Canister - 2.5L NA V6 - AJV6/3.0L NA V6 - AJ27

Evaporative Emission Canister Purge Valve

303-14A: Electronic Engine Controls - 2.5L NA V6 - AJV6/2.0L NA V6 - AJV6/3.0L NA V6 - AJ27

Specification

Description and Operation

Electronic Engine Controls

Diagnosis and Testing

Electronic Engine Controls - 2.0L NA V6 - AJV6

Electronic Engine Controls - 2.5L NA V6 - AJV6/3.0L NA V6 - AJ27, VIN Range: E96603->J28492

Electronic Engine Controls - 2.5L NA V6 - AJV6/3.0L NA V6 - AJ27, VIN Range: J28493->V99999

General Procedures

Powertrain Control Module (PCM) Long Drive Cycle Self-Test

Powertrain Control Module (PCM) Short Drive Cycle Self-Test

Removal and Installation

Camshaft Position (CMP) Sensor

Catalyst Monitor Sensor LH

Catalyst Monitor Sensor RH

Crankshaft Position (CKP) Sensor

Engine Control Module (ECM)

Fuel Temperature Sensor - 2.5L NA V6 - AJV6/3.0L NA V6 - AJ27

Heated Oxygen Sensor (HO2S) LH

Heated Oxygen Sensor (HO2S) RH

Knock Sensor (KS)

Mass Air Flow (MAF) Sensor

Oil Temperature Sensor

Throttle Position (TP) Sensor

Variable Camshaft Timing (VCT) Oil Control Solenoid

303-14B: Electronic Engine Controls - 2.2L Duratorq-TDCi (110kW/150PS) - Puma/2.0L Duratorq-TDCi Specification

Description and Operation

Electronic Engine Controls

Diagnosis and Testing

Electronic Engine Controls

Removal and Installation

Camshaft Position (CMP) Sensor

Catalytic Converter Temperature Sensor

Crankshaft Position (CKP) SensorCylinder Head Temperature (CHT) Sensor

Diesel Particulate Filter (DPF) Temperature Sensor

Engine Control Module (ECM)

Engine Oil Pressure (EOP) Sensor

Fuel Temperature Sensor

Knock Sensor (KS)Manifold Absolute Pressure and Temperature (MAPT) Sensor

Manifold Absolute Pressure (MAP) Sensor

Mass Air Flow (MAF) Sensor

307: Automatic Transmission/Transaxle

307-01A: Automatic Transmission/Transaxle - Vehicles With: 5-Speed Automatic Transaxle - JATCO Specification

Description and Operation

Transmission Description - Vehicles With: 5-Speed Automatic Transaxle - JATCO

Diagnosis and Testing

Diagnostic Strategy - Vehicles With: 5-Speed Automatic Transaxle - JATCO

General Procedures

Transmission Fluid Drain and Refill

Transmission Fluid Level Check

Transmission Range (TR) Sensor Adjustment

In-Vehicle Repair

Halfshaft Seal LH

Halfshaft Seal RH

Main Control Valve Body

Shift Solenoids (SS)
Transaxle Support Insulator
Transmission Control Module (TCM)
Transmission Range (TR) Sensor

Removal
Transaxle

Disassembly and Assembly of Subassemblies
Input Shaft Seal

Installation
Transaxle

307-01B: Automatic Transmission/Transaxle - Vehicles With: 6-Speed Automatic Transaxle - AWF21
Specification

Description and Operation

Transmission Description - Vehicles With: 6-Speed Automatic Transaxle - AWF21
Transmission Electronic Control System - Vehicles With: 6-Speed Automatic Transaxle - AWF21

Diagnosis and Testing

Diagnostic Strategy - Vehicles With: 6-Speed Automatic Transaxle - AWF21

General Procedures

Transmission Fluid Drain and Refill
Transmission Fluid Level Check

In-Vehicle Repair

Main Control Valve Body
Selector Shaft Seal
Transmission Control Module (TCM)
Transmission Internal Wiring Harness
Transmission Fluid Pan

Removal and Installation

Transmission Control Unit Solenoids
Torque Converter
Torque Converter Seal
Turbine Shaft Speed (TSS) Sensor

Removal

Transmission

Installation

Transmission

307-02A: Transmission/Transaxle Cooling - Vehicles With: 5-Speed Automatic Transaxle - JATCO
Specification

Description and Operation

Transmission Cooling - Vehicles With: 5-Speed Automatic Transaxle - JATCO

Diagnosis and Testing

Transmission Cooling

Removal and Installation

Transmission Fluid Cooler
Transmission Fluid Cooler Tubes

307-02B: Transmission/Transaxle Cooling - Vehicles With: 6-Speed Automatic Transaxle - AWF21
Specification

Description and Operation

Transmission Cooling - Vehicles With: 6-Speed Automatic Transaxle - AWF21

Diagnosis and Testing

Transmission Cooling

Removal and Installation

Transmission Fluid Cooler
Transmission Fluid Cooler Return Tube

Transmission Fluid Cooler Supply Tube

307-05A: Automatic Transmission/Transaxle External Controls - Vehicles With: 5-Speed Automatic Transaxle - JATCO

Specification

Description and Operation

External Controls - Vehicles With: 5-Speed Automatic Transaxle - JATCO

Diagnosis and Testing

External Controls

General Procedures

Selector Lever Cable Adjustment

Removal and Installation

Selector Lever Cable and Bracket

Selector Lever Assembly

307-05B: Automatic Transmission/Transaxle External Controls - Vehicles With: 6-Speed Automatic Transaxle - AWF21

Specification

Description and Operation

External Controls - Vehicles With: 6-Speed Automatic Transaxle - AWF21

Diagnosis and Testing

External Controls

General Procedures

Selector Lever Cable Adjustment

Removal and Installation

Selector Lever Assembly

Selector Lever Knob

308: Manual Transmission/Transaxle, Clutch and Transfer Case

308-00: Manual Transmission/Transaxle and Clutch - General Information

Specification

Description and Operation

Manual Transmission and Clutch

Diagnosis and Testing

Manual Transmission and Clutch

General Procedures

Clutch System Bleeding - Vehicles With: 5-Speed Manual Transmission - MT75

Clutch System Bleeding - Vehicles With: 6-Speed Manual Transaxle - MMT6

Gearshift Cable Adjustment

Release Hub and Bearing Check

308-01: Clutch

Specification

Description and Operation

Clutch

Diagnosis and Testing

Clutch

Removal and Installation

Clutch Disc and Pressure Plate

308-02: Clutch Controls

Specification

Description and Operation

Clutch Controls

Diagnosis and Testing

Clutch Controls

Removal and Installation

Clutch Master Cylinder

Clutch Slave Cylinder - Vehicles With: 5-Speed Manual Transmission - MT75

Clutch Slave Cylinder - Vehicles With: 6-Speed Manual Transaxle - MMT6

308-03: Manual Transmission/Transaxle

Specification

Description and Operation

Manual Transaxle - Vehicles With: 5-Speed Manual Transmission - MT75

Manual Transaxle - Vehicles With: 6-Speed Manual Transaxle - MMT6

Diagnosis and Testing

Manual Transaxle

General Procedures

Transaxle Draining and Filling - Vehicles With: 5-Speed Manual Transmission - MT75

Transaxle Draining and Filling - Vehicles With: 6-Speed Manual Transaxle - MMT6

In-Vehicle Repair

Halfshaft Seal LH

Halfshaft Seal RH

Input Shaft Seal

Selector Mechanism - Vehicles With: 5-Speed Manual Transmission - MT75

Selector Mechanism - Vehicles With: 6-Speed Manual Transaxle - MMT6

Support Insulator

Removal

Transaxle - 2.0L Duratorq-TDCi

Transaxle - 2.2L Duratorq-TDCi (110kW/150PS) - Puma

Transaxle - 2.5L NA V6 - AJV6/2.0L NA V6 - AJV6/3.0L NA V6 - AJ27

Installation

Transaxle - 2.0L Duratorq-TDCi

Transaxle - 2.2L Duratorq-TDCi (110kW/150PS) - Puma

Transaxle - 2.5L NA V6 - AJV6/2.0L NA V6 - AJV6/3.0L NA V6 - AJ27

308-06: Manual Transmission/Transaxle External Controls

Specification

Description and Operation

External Controls

Diagnosis and Testing

External Controls

Removal and Installation

Gearshift Cables - Vehicles With: 5-Speed Manual Transmission - MT75

Gearshift Cables - Vehicles With: 6-Speed Manual Transaxle - MMT6

Gearshift Lever - Vehicles With: 5-Speed Manual Transmission - MT75

Gearshift Lever - Vehicles With: 6-Speed Manual Transaxle - MMT6

308-07: Transfer Case

Specification

Description and Operation

Transfer Case

General Procedures

Transfer Case Draining and Filling

In-Vehicle Repair

Halfshaft Seal RH

Transfer Case Rear Output Shaft Seal

Removal

Transfer Case

Installation

Transfer Case

309-00: Exhaust System Specification

Description and Operation

Exhaust System

Diagnosis and Testing

Exhaust System

Removal and Installation

Catalytic Converter - 2.2L Duratorq-TDCi (110kW/150PS) - Puma/2.0L Duratorq-TDCi

Catalytic Converter LH - 2.5L NA V6 - AJV6/2.0L NA V6 - AJV6/3.0L NA V6 - AJ27

Catalytic Converter RH - 2.5L NA V6 - AJV6/2.0L NA V6 - AJV6/3.0L NA V6 - AJ27

Diesel Particulate Filter (DPF)

Diesel Particulate Filter (DPF) Differential Pressure Sensor

Exhaust Flexible Pipe - 2.2L Duratorq-TDCi (110kW/150PS) - Puma/2.0L Duratorq-TDCi

Front Muffler - 2.2L Duratorq-TDCi (110kW/150PS) - Puma/2.0L Duratorq-TDCi

Front Muffler - 2.5L NA V6 - AJV6/2.0L NA V6 - AJV6/3.0L NA V6 - AJ27

Muffler and Tailpipe - 2.2L Duratorq-TDCi (110kW/150PS) - Puma/2.0L Duratorq-TDCi, 2.0L

Muffler and Tailpipe - 2.5L NA V6 - AJV6/3.0L NA V6 - AJ27

Muffler Inlet Pipe - 2.5L NA V6 - AJV6/2.0L NA V6 - AJV6/3.0L NA V6 - AJ27

Muffler Inlet Pipe - Vehicles With: Diesel Particulate Filter (DPF)

310-00: Fuel System - General Information

Specification

Description and Operation

Fuel System

Diagnosis and Testing

Fuel System

General Procedures

Fuel System Pressure Check

Fuel System Pressure Release

Fuel Tank Draining - 2.2L Duratorq-TDCi (110kW/150PS) - Puma/2.0L Duratorq-TDCi

Fuel Tank Draining - 2.5L NA V6 - AJV6/2.0L NA V6 - AJV6/3.0L NA V6 - AJ27

Quick Release Coupling - Push Connect

Spring Lock Couplings

310-01: Fuel Tank and Lines

Specification

Description and Operation

Fuel Tank and Lines

Diagnosis and Testing

Fuel Tank and Lines

Removal and Installation

Fuel Filter - 2.2L Duratorq-TDCi (110kW/150PS) - Puma/2.0L Duratorq-TDCi

Fuel Filter - 2.5L NA V6 - AJV6/2.0L NA V6 - AJV6/3.0L NA V6 - AJ27

Fuel Level Sender - 2.0L NA V6 - AJV6

Fuel Level Sender - 2.2L Duratorq-TDCi (110kW/150PS) - Puma/2.0L Duratorq-TDCi

Fuel Level Sender LH - 2.5L NA V6 - AJV6/3.0L NA V6 - AJ27

Fuel Level Sender RH - 2.5L NA V6 - AJV6/3.0L NA V6 - AJ27

Fuel Level Sensor - 2.2L Duratorq-TDCi (110kW/150PS) - Puma/2.0L Duratorq-TDCi

Fuel Pump Module - 2.0L NA V6 - AJV6

Fuel Pump Module - 2.5L NA V6 - AJV6/3.0L NA V6 - AJ27

Fuel Tank - 2.0L NA V6 - AJV6

Fuel Tank - 2.2L Duratorq-TDCi (110kW/150PS) - Puma/2.0L Duratorq-TDCi

Fuel Tank - 2.5L NA V6 - AJV6/3.0L NA V6 - AJ27

Fuel Tank Filler Pipe

Gas Fuel Tank Pressure Sensor

Fuel Transfer Pump

Inertia Fuel Shutoff (IFS) Switch

310-02: Acceleration Control
Specification

Description and Operation
Acceleration Control

Diagnosis and Testing
Acceleration Control

General Procedures
Accelerator Cable Adjustment - 2.0L NA V6 - AJV6

Removal and Installation
Accelerator Cable - 2.0L NA V6 - AJV6
Accelerator Pedal

310-03: Speed Control
Specification

Description and Operation
Speed Control

Diagnosis and Testing
Speed Control - 2.0L NA V6 - AJV6
Speed Control - 2.5L NA V6 - AJV6/3.0L NA V6 - AJ27

Removal and Installation
Speed Control Deactivator Switch
Speed Control Module
Speed Control Switch

4: Electrical

412-00: Climate Control System - General Information
Specification

Description and Operation
Climate Control System

Diagnosis and Testing
Climate Control System

General Procedures
Air Conditioning (A/C) Compressor Leak Detection
Air Conditioning (A/C) System Flushing
Air Conditioning (A/C) System Recovery, Evacuation and Charging
Contaminated Refrigerant Handling
Discharging and Recovery
Electronic Leak Detection
Inspection and Assembly Requirements
Leak Detection
Refrigerant Oil Adding
Refrigerant System Tests

412-01: Air Distribution and Filtering

Description and Operation
Air Distribution and Filtering

Diagnosis and Testing
Air Distribution and Filtering

Removal and Installation
Center Registers
Driver Side Register
Front Footwell Duct LH
Front Footwell Duct RH
Passenger Side Register
Pollen Filter

412-02A: Heating and Ventilation
Specification

Description and Operation

Heating and Ventilation

Diagnosis and Testing

Heating and Ventilation

Removal and Installation

Blower Motor

Evaporator Core Housing

Heater Core

Disassembly and Assembly

Evaporator Core Housing

412-02B: Auxiliary Heating
Specification

Description and Operation

Electric Booster Heater

Fuel Fired Booster Heater

Diagnosis and Testing

Auxiliary Heater

Fuel Fired Booster Heater

Removal and Installation

Electric Booster Heater

Fuel Fired Booster Heater

412-03: Air Conditioning
Specification

Description and Operation

Air Conditioning

Diagnosis and Testing

Air Conditioning

Removal and Installation

Air Conditioning (A/C) Compressor - 2.5L NA V6 - AJV6/2.0L NA V6 - AJV6/3.0L NA V6 - AJ27

Air Conditioning (A/C) Compressor - 2.2L Duratorq-TDCi (110kW/150PS) - Puma/2.0L Duratorq-TDCi

Air Conditioning (A/C) Pressure Transducer

Clutch and Clutch Field Coil - 2.5L NA V6 - AJV6/2.0L NA V6 - AJV6/3.0L NA V6 - AJ27

Condenser Core

Evaporator Core

Evaporator Core Orifice

Suction Accumulator

412-04: Control Components

Description and Operation

Control Components

Diagnosis and Testing

Control Components

Removal and Installation

Air Discharge Temperature Sensor

Air Inlet Blend Door Actuator

Ambient Air Temperature Sensor

Climate Control Assembly

Defrost Vent/Register Blend Door Actuator

Footwell Vent/Duct Blend Door Actuator

Sunload Sensor

Temperature Blend Door Actuator

413: Instrumentation and Warning Systems

413-00: Instrument Cluster and Panel Illumination

Diagnosis and Testing

Instrument Cluster and Panel Illumination

413-01: Instrument Cluster

Description and Operation

Instrument Cluster

Diagnosis and Testing

Instrument Cluster

Removal and Installation

Instrument Cluster

413-06: Horn

Description and Operation

Horn

Diagnosis and Testing

Horn

Removal and Installation

Horn

Horn Switch

413-08: Information and Message Center

Description and Operation

Information and Message Center

Diagnosis and Testing

Information and Message Center

Removal and Installation

Message Center

Message Center Switch

413-09: Warning Devices

Description and Operation

Warning Devices

Diagnosis and Testing

Warning Devices

General Procedures

Oil Change Indicator Reset

Removal and Installation

Low Washer Fluid Warning Indicator Switch

413-13: Parking Aid

Description and Operation

Parking Aid

Diagnosis and Testing

Parking Aid

Removal and Installation

Front Parking Aid Sensor

Front Parking Aid Speaker

Parking Aid Module - 4-Door

Parking Aid Module - Wagon

Rear Parking Aid Sensor

Rear Parking Aid Speaker - 4-Door

Rear Parking Aid Speaker - Wagon, VIN Range: D86655->E43419

Rear Parking Aid Speaker - Wagon, VIN Range: E43420->V99999

414: Battery and Charging System

414-00: Charging System - General Information

Description and Operation

Charging System

Diagnosis and Testing

Charging System - 2.5L NA V6 - AJV6/2.0L NA V6 - AJV6/3.0L NA V6 - AJ27

Charging System - 2.2L Duratorq-TDCi (110kW/150PS) - Puma/2.0L Duratorq-TDCi

General Procedures

Battery Charging

414-01: Battery, Mounting and Cables

Specification

Description and Operation

Battery and Cables

Diagnosis and Testing

Battery

General Procedures

Battery Connect

Battery Disconnect and Connect

Removal and Installation

Battery

Battery Cables - 2.5L NA V6 - AJV6/2.0L NA V6 - AJV6/3.0L NA V6 - AJ27

Battery Cables - 2.2L Duratorq-TDCi (110kW/150PS) - Puma/2.0L Duratorq-TDCi

Battery Tray

414-02: Generator and Regulator

Specification

Description and Operation

Generator

Diagnosis and Testing

Generator

Removal and Installation

Generator - 2.5L NA V6 - AJV6/2.0L NA V6 - AJV6/3.0L NA V6 - AJ27

Generator - 2.2L Duratorq-TDCi (110kW/150PS) - Puma/2.0L Duratorq-TDCi

415: Information and Entertainment Systems

415-00: Information and Entertainment System - General Information

Diagnosis and Testing

Audio System

415-01: Audio Unit

Description and Operation

Audio System

Diagnosis and Testing

Audio System

Removal and Installation

Audio Unit

Audio Unit Amplifier - 4-Door

Audio Unit Amplifier - Wagon

Compact Disc (CD) Changer - 4-Door

Compact Disc (CD) Changer - Wagon

Steering Wheel Audio Controls

415-02: Antenna

Specification

Description and Operation

Antenna

Diagnosis and Testing

Antenna

Removal and Installation

Antenna - Wagon

Module

415-03: Speakers

Description and Operation

Speakers

Diagnosis and Testing

Speakers

Removal and Installation

Front Door Speaker

Front Door Tweeter Speaker

Parcel Shelf Speaker

Rear Door Speaker

Rear Door Tweeter Speaker

417: Lighting

417-01: Exterior Lighting

Specification

Description and Operation

Exterior Lighting

Diagnosis and Testing

Headlamps

General Procedures

Headlamp Adjustment

Removal and Installation

Ballast

Front Fog Lamp

Headlamp Assembly

Headlamp Bulb - Vehicles With: High Intensity Discharge Headlamps

Headlamp Leveling Module

Headlamp Leveling Sensor

Headlamp Switch

High Mounted Stoplamp - 4-Door

High Mounted Stoplamp - Wagon

Rear Lamp Assembly - 4-Door

Rear Lamp Assembly - Wagon

417-02: Interior Lighting

Description and Operation

Interior Lighting

Diagnosis and Testing

Interior Lighting

Removal and Installation

Front Interior Lamp

Rear Interior Lamp

417-04: Daytime Running Lamps (DRL)

Description and Operation

Daytime Running Lamps (DRL)

Diagnosis and Testing

Daytime Running Lamps (DRL)

418: Electrical Distribution

418-00: Module Communications Network

Description and Operation
Communications Network

Diagnosis and Testing
Communications Network - VIN Range: E96603->J28492
Communications Network - VIN Range: J28493->V99999

418-01: Module Configuration

Diagnosis and Testing
Module Configuration

General Procedures
Module Configuration

418-02: Wiring Harnesses

Description and Operation
Wiring Harness

General Procedures
Wiring Harness Repair

419: Electronic Feature Group

419-01A: Anti-Theft - Active

Description and Operation
Anti-Theft - Active

Diagnosis and Testing
Anti-Theft - Active

Removal and Installation
Anti-Theft Alarm Horn

419-01B: Anti-Theft - Passive

Description and Operation
Anti-Theft - Passive

Diagnosis and Testing
Anti-Theft - Passive

General Procedures
Anti-Theft Security Access
Key Programming Using Diagnostic Equipment
Removal and Installation
Passive Anti-Theft System (PATS) Transceiver

419-02: Remote Convenience

Description and Operation
Universal Transmitter

Diagnosis and Testing
Universal Transmitter

General Procedures
Universal Transmitter Programming

419-07: Navigation System

Description and Operation
Navigation System

Diagnosis and Testing
Navigation System

Removal and Installation

Navigation System Antenna - 4-Door, VIN Range: E96603->J39905

Navigation System Antenna - 4-Door, VIN Range: J39906->V99999

Navigation System Antenna - Wagon

Navigation System Display Module

Navigation System Module - 4-Door

Navigation System Module - Wagon

419-08: Cellular Phone

Specification

Description and Operation

Cellular Phone

Diagnosis and Testing

Cellular Phone

Cellular Phone - Vehicles With: Bluetooth

Removal and Installation

Bluetooth Module

Handset Holder

Module - 4-Door

Module – Wagon

419-10: Multifunction Electronic Modules

Specification

Description and Operation

Module Controlled Functions

Diagnosis and Testing

Multifunction Electronic Module

Removal and Installation

Generic Electronic Module (GEM)

Multifunction Voice Activated Module - 4-Door

Multifunction Voice Activated Module - Wagon

5: Body and Paint

501: Body and Paint

501-02: Front End Body Panels

Description and Operation

Front End Body Panels

Removal and Installation

Air Deflector - 2.2L Duratorq-TDCi (110kW/150PS) - Puma/2.0L Duratorq-TDCi

Cowl Vent Screen

Fender Splash Shield

Radiator Splash Shield

501-03: Body Closures

Specification

Description and Operation

Body Closures

General Procedures

Door Alignment

Hood Alignment

Liftgate Alignment

Luggage Compartment Lid Alignment

Removal and Installation

Weatherstrip

501-05: Interior Trim and Ornamentation
Specification

Description and Operation

Interior Trim

Removal and Installation

A-Pillar Trim Panel
B-Pillar Lower Trim Panel
B-Pillar Upper Trim Panel
Cowl Side Trim Panel
C-Pillar Trim Panel - 4-Door
C-Pillar Trim Panel - Wagon
D-Pillar Trim Panel
Front Door Trim Panel
Front Scuff Plate Trim Panel
Headliner - 4-Door
Headliner - Wagon
Liftgate Trim Panel
Loadspace Scuff Plate Trim Panel
Loadspace Trim Panel
Parcel Shelf
Rear Door Trim Panel
Rear Scuff Plate Trim Panel
Rear Window Blind
Sun Visor

501-08: Exterior Trim and Ornamentation
Specification

Description and Operation

Exterior Trim

Removal and Installation

Door Moulding
Liftgate Moulding
Radiator Grille
Rear Spoiler - Wagon
Rocker Panel Moulding
Roof Rail
Window Moulding

501-09: Rear View Mirrors
Specification

Description and Operation

Rear View Mirrors

Diagnosis and Testing

Rear View Mirrors

Removal and Installation

Auto-Dimming Interior Mirror
Exterior Mirror
Exterior Mirror Control Switch
Exterior Mirror Cover
Exterior Mirror Glass
Exterior Mirror Motor
Interior Mirror

501-10: Seating
Specification

Description and Operation

Seats

Diagnosis and Testing

Seats

Removal and Installation

- Front Seat
- Front Seat Backrest
- Front Seat Cushion
- Front Seat Front Height Adjustment Motor
- Front Seat Rear Height Adjustment Motor
- Front Seat Recliner Motor
- Front Seat Track Motor
- Lumbar Assembly
- Rear Seat Backrest - 4-Door
- Rear Seat Backrest - 4-Door, Vehicles With: 70/30 Split Seat
- Rear Seat Backrest - Wagon, Vehicles With: 70/30 Split Seat
- Rear Seat Backrest Latch - Wagon
- Rear Seat Bolster - 4-Door
- Rear Seat Bolster - Wagon
- Rear Seat Cushion
- Seat Base
- Seat Control Switch

Disassembly and Assembly

- Front Seat Backrest
- Front Seat Cushion
- Rear Seat Backrest - 4-Door, Vehicles With: 70/30 Split Seat
- Rear Seat Backrest - Wagon, Vehicles With: 70/30 Split Seat
- Rear Seat Backrest
- Rear Seat Bolster
- Rear Seat Cushion

501-11: Glass, Frames and Mechanisms Specification

Description and Operation

- Glass, Frames and Mechanisms

Diagnosis and Testing

- Glass, Frames and Mechanisms

General Procedures

- Door Window Motor Initialization
- Liftgate Window Glass Adjustment

Removal and Installation

- Front Door Window Glass
- Front Door Window Regulator and Motor
- Liftgate Window Glass
- Rear Door Fixed Window Glass
- Rear Door Window Glass
- Rear Door Window Regulator
- Rear Door Window Regulator and Motor
- Rear Quarter Window Glass
- Rear Window Glass Using Cheese Wire
- Rear Window Glass Using Cutting Tool
- Window Control Switch
- Windshield Glass Using Cheese Wire
- Windshield Glass Using Cutting Tool

501-12: Instrument Panel and Console

Description and Operation

- Instrument Panel

Removal and Installation

- Floor Console
- Instrument Panel
- Overhead Console
- Overhead Console Switch Moulding

501-14: Handles, Locks, Latches and Entry Systems
Specification

Description and Operation

Handles, Locks, Latches and Entry Systems

Diagnosis and Testing

Locks, Latches and Entry Systems

General Procedures

Remote Transmitter Programming

Removal and Installation

Exterior Front Door Handle

Front Door Lock Actuator

Front Door Lock Cylinder

Fuel Filler Door Release Handle and Cable - 4-Door

Fuel Filler Door Release Handle and Cable - Wagon

Liftgate Latch Actuator

Liftgate Window Glass Release Switch

Luggage Compartment Lid Latch Actuator

Rear Door Lock Actuator

501-16: Wipers and Washers
Specification

Description and Operation

Wipers and Washers

Diagnosis and Testing

Wipers and Washers

Removal and Installation

Headlamp Washer Pump

Rain Sensor

Rain Sensor Module

Rear Window Wiper Motor

Windshield and Rear Window Washer Pump

Windshield Washer Pump

Windshield Washer Reservoir

Windshield Wiper Motor

Wiper Mounting Arm and Pivot Shaft

Wiper Pivot Arm

501-17: Roof Opening Panel
Specification

Description and Operation

Roof Opening Panel

Diagnosis and Testing

Roof Opening Panel

General Procedures

Motor Synchronization

Roof Opening Panel Alignment

Removal and Installation

Air Deflector

Lifter Arms

Roof Opening Panel Control Switch

Roof Opening Panel Drain Hose

Roof Opening Panel Frame

Roof Opening Panel Glass

Roof Opening Panel Motor

Roof Opening Panel Shield

Roof Opening Panel Weatherstrip

501-19: Bumpers

Specification

Description and Operation

Bumpers

Removal and Installation

Front Bumper Cover

Front Bumper Cover Insert

Rear Bumper - 4-Door

Rear Bumper - Wagon

Rear Bumper Cover - 4-Door

Rear Bumper Cover - Wagon

Rear Bumper Cover Insert - 4-Door

Rear Bumper Cover Insert - Wagon

501-20A: Safety Belt System

Specification

Description and Operation

Safety Belt System

Diagnosis and Testing

Safety Belt System

Removal and Installation

Front Safety Belt Retractor

Front Safety Belt Shoulder Height Adjuster

Rear Center Safety Belt Retractor - 4-Door

Rear Center Safety Belt Retractor - Wagon

Rear Safety Belt Buckle

Rear Safety Belt Retractor - 4-Door

Rear Safety Belt Retractor - Wagon

Safety Belt Buckle and Pretensioner

501-20B: Supplemental Restraint System

Specification

Description and Operation

Air Bag Supplemental Restraint System (SRS)

Diagnosis and Testing

Air Bag Supplemental Restraint System (SRS)

General Procedures

Air Bag Disposal

Removal and Installation

Clockspring

Crash Sensor

Driver Air Bag Module

Driver Lower Air Bag Module

Occupant Classification Sensor

Passenger Air Bag Deactivation (PAD) Indicator

Passenger Air Bag Module

Restraints Control Module (RCM)

Seat Position Sensor

Side Air Curtain Module - 4-Door

Side Air Curtain Module - Wagon

Side Impact Sensor

502: Frame and Mounting

502-00: Uni-Body, Subframe and Mounting System

Specification

Description and Operation

Frame Assembly

General Procedures

Underbody Misalignment Check

Removal and Installation

Front Subframe - 2.5L NA V6 - AJV6/2.0L NA V6 - AJV6/3.0L NA V6 - AJ27

Front Subframe - 2.2L Duratorq-TDCi (110kW/150PS) - Puma/2.0L Duratorq-TDCi

Front Subframe Front Bushing

Front Subframe Rear Bushing

Rear Axle Crossmember Bushing

Rear Subframe

Rear Subframe Bushing

About This Manual

Notes, Cautions and Warnings

Throughout this manual, important information is highlighted by the use of notes, cautions and warnings. NOTES give additional information on a topic or procedure, CAUTIONS are given to prevent damage to the vehicle, and WARNINGS are given to prevent personal injury.

Application and Use of Specifications

Torque Specifications

Torque specifications, when available, are shown in the torque specifications chart located at the front of the relevant section.

General Service Information

Repairs and Replacements

When service parts are required, it is essential that only genuine Jaguar/Daimler replacements are used.

Attention is drawn to the following points concerning repairs and the fitting of replacement parts and accessories:

- Safety features embodied in the vehicle may be impaired if other than genuine parts are fitted. In certain territories, legislation prohibits the fitting of parts which are not produced to the vehicle manufacturer's specification.
- Torque wrench setting figures given in this manual must be strictly adhered to. Locking devices, where specified, must be fitted. If the efficiency of a locking device is impaired during removal it must be renewed.
- Owners purchasing accessories while travelling abroad should make sure that the accessory and its fitted location on the vehicle conform to mandatory requirements existing in their country of origin.
- The vehicle warranty may be invalidated by the fitting of other than genuine Jaguar/Daimler parts. All Jaguar/Daimler replacements have the full backing of the factory warranty.
- Jaguar/Daimler dealers are obliged to supply only genuine service parts.

Vehicle Specifications

Purchasers are advised that the specification details set out in this manual apply to a range of vehicles and not to any specific one. For the specification of a particular vehicle, purchasers should consult their dealer.

The Manufacturer reserves the right to vary the specifications, with or without notice, and at such times and in such manner as the Manufacturer thinks fit. Major as well as minor changes may be involved, in accordance with the Manufacturer's policy of continuous improvement.

Whilst every effort is made to make sure the accuracy of the particulars contained in this manual, neither the Manufacturer nor the Dealer, by whom the manual is supplied, shall in any circumstances be held liable for any inaccuracy or the consequences thereof.

Service Repair Operation Numbering

A master index of numbered operations has been compiled for universal application to all vehicles manufactured by Jaguar Cars Ltd.

Each operation is allocated a number from the master index and cross-refers with an identical number in the Repair Operation Times schedule. The number consists of six digits arranged in three pairs.

Each maintenance procedure in this manual is described in the sequence necessary to complete the operation in the minimum time, as specified in the Repair Operation Times schedule.

References to Bank-1 and Bank-2

References to Bank-1 and Bank-2 are made with regard to the engine. When viewed from the flywheel the right-hand bank will be Bank-1 and the left-hand bank will be Bank-2.

Special Tools

Any special tools and equipment required to perform a maintenance procedure, are shown at the beginning of each procedure. When possible, illustrations are given to assist in identifying the tool needed.

Disconnecting/Connecting the Battery

Always stop the engine before disconnecting the battery negative lead and make sure the battery positive lead is isolated i.e. wrapped in a suitable cloth.



WARNING: Radio code saving devices must not be used when conducting work on Air Bag or Fuel systems. It must be noted that, when using these devices, the vehicle electrical system is still live albeit with a reduced current flow.

NOTE:

Before disconnecting the battery make sure that the radio receiver/cassette player/mini disc player and compact disc player keycodes are known and, that no data is required from the engine control module (ECM) as battery disconnection will erase any fault codes and idle/drive values held in the Keep Alive Memory (KAM). It is not necessary to disconnect or remove electronic control modules.

Always disconnect the battery before commencing repair operations which require:

- The vehicle to be jacked up
- Work on the engine
- Work underneath the vehicle
- Arc welding

Alternatively a Radio Code Saver may be used. With the battery disconnected, a Radio Code Saver will allow sufficient current to pass to maintain the radio receiver/cassette player/mini disc player and compact disc player memory, operate the clock and supply the door operated interior lights while isolating the battery in the event of a short circuit.

Reconnecting the Battery



WARNING: If the battery has been on bench charge the cells may be giving off explosive hydrogen gas. Avoid creating sparks, and if in doubt cover the vent plugs or covers with a damp cloth.

Always make sure that all electrical systems are switched OFF before reconnecting the battery to avoid causing sparks or damage to sensitive electrical equipment.

Always reconnect the battery positive lead first and the negative last, ensuring that there is a good electrical contact and the battery terminals are secure.

Restart the clock (where fitted) and set it to the correct time.

Re - enter the radio receiver/cassette player/mini disc player and compact disc player keycodes and preset frequencies, if known.

Following reconnection of the battery, the engine should be allowed to idle until it has reached normal operating temperature as the stored idle and drive values contained within the ECM have been lost. Allow the vehicle to idle for a further three minutes. Drive the vehicle at constant speeds of approximately 48 km/h (30 mph), 64 km/h (40 mph), 80 km/h (50 mph), 96 km/h (60 mph) and 112 km/h (70 mph) for three minutes each. This may cause a driveability concern if the procedure is not carried out. This will allow the ECM to relearn idle values.

Connecting a Slave Battery Using Jump Leads



WARNING: If the slave battery has recently been charged and is gassing, cover the vent plugs or covers with a damp cloth to reduce the risk of explosion should arcing occur when connecting the jump leads.



CAUTION: A flat battery condition may have been caused by an electrical short circuit. If this condition exists there will be an apparently live circuit on the vehicle even when all normal circuits are switched off. This can cause arcing when the jump leads are connected.



CAUTION: Whilst it is not recommended that the vehicle is jump started, it is recognized that this may occasionally be the only practical way to mobilize a vehicle. In such an instance the discharged battery must be recharged immediately after jump starting to avoid permanent damage.

- Always make sure that the jump leads are adequate for the task. Heavy duty cables must be used.
- Always make sure that the slave battery is of the same voltage as the vehicle battery. The batteries must be connected in parallel.
- Always make sure that switchable electric circuits are switched off before connecting jump leads. This reduces the risk of sparks occurring when the final connection is made.

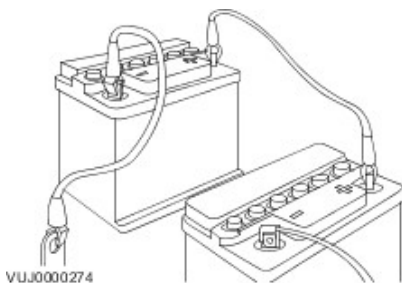

WARNING: Make sure that the ends of the jump leads do not touch each other or ground against the vehicle body at any time while the leads are attached to the battery. A fully charged battery, if shorted through jump leads, can discharge at a rate well above 1000 amps causing violent arcing and very rapid heating of the jump leads and terminals, and can even cause the battery to explode.

Always connect the jump leads in the following sequence.

- Slave battery positive first then vehicle battery positive.
- Slave battery negative next and then vehicle ground at least, 300 mm (12 in) from the battery terminal e.g. engine lifting bracket.

Always reduce the engine speed to idle before disconnecting the jump leads.

Before removing the jump leads from the vehicle that had the discharged battery, switch on the heater blower (high) or the heated rear screen, to reduce the voltage peak when the leads are removed.

Always disconnect the jump leads in the reverse order to the connecting sequence and take great care not to short the ends of the leads.

Do not rely on the alternator to restore a discharged battery. For an alternator to recharge a battery, it would take in excess of 8 hours continuous driving with no additional loads placed on the battery.

Component Cleaning

To prevent ingress of dirt, accumulations of loose dirt and greasy deposits should be removed before disconnecting or dismantling components or assemblies.

Components should be thoroughly cleaned before inspection prior to reassembly.

Cleaning Methods:

- Dry Cleaning
- Removal of loose dirt with soft or wire brushes.
- Scraping dirt off with a piece of metal or wood.
- Wiping off with a rag.



CAUTION: Compressed air is sometimes wet so use with caution, especially on hydraulic systems.

- Blowing dirt off with compressed air. (Eye protection should be worn when using this method).
- Removal of dry dust using vacuum equipment. This method should always be used to remove friction lining material dust (asbestos particles).
- Steam Cleaning

Calibration of Essential Measuring Equipment



WARNING: Failure to comply may result in personal injury or damage to components.

It is of fundamental importance that certain essential equipment e.g. torque wrenches, multimeters, exhaust gas analysers, rolling roads etc., are regularly calibrated in accordance with the manufacturers instructions.

Use of Control Modules

Control modules may only be used on the vehicle to which they were originally fitted. Do not attempt to use or test a control module on any other vehicle.

Functional Test

On completion of a maintenance procedure, a thorough test should be carried out, to make sure that the relevant vehicle systems are working correctly.

Preparation

Before disassembly, clean the surrounding area as thoroughly as possible. When components have been removed, blank off any exposed openings using grease-proof paper and masking tape. Immediately seal fuel, oil and hydraulic lines when separated, using plastic caps or plugs, to prevent loss of fluid and the entry of dirt. Close the open ends of oilways, exposed by component removal, with tapered hardwood plugs or readily visible plastic plugs. Immediately a component is removed, place it in a suitable container; use a separate container for each component and its associated parts. Before dismantling a component, clean it thoroughly with a recommended cleaning agent; check that the agent will not damage any of the materials within the component. Clean the bench and obtain marking materials, labels, containers and locking wire before dismantling a component.

Dismantling

Observe scrupulous cleanliness when dismantling components, particularly when parts of the brake, fuel or hydraulic systems are being worked on. A particle of dirt or a fragment of cloth could cause a dangerous malfunction if trapped in these systems. Clean all tapped holes, crevices, oilways and fluid passages with compressed air. Do not permit compressed air to enter an open wound. Always use eye protection when using compressed air.

Make sure that any O-rings used for sealing are correctly refitted or renewed if disturbed. Mark mating parts to make sure that they are replaced as dismantled. Whenever possible use marking materials which avoid the possibilities of causing distortion or the initiation of cracks, which could occur if a center punch or scriber were used. Wire together mating parts where necessary to prevent accidental interchange (e.g roller bearing components). Tie labels on to all parts to be renewed and to parts requiring further inspection before being passed for reassembly. Place labelled parts and other parts for rebuild in separate containers. Do not discard a part which is due for renewal until it has been compared with the new part, to make sure that the correct part has been obtained.

Inspection

Before inspecting a component for wear or performing a dimensional check, make sure that it is absolutely clean; a slight smear of grease can conceal an incipient failure. When a component is to be checked dimensionally against figures quoted for it, use the correct equipment (surface plates, micrometers, dial gauges etc.) in serviceable condition. The use of makeshift equipment can be dangerous. Reject a component if its dimensions are outside the limits quoted, or if damage is apparent. A part may be refitted if its critical dimension is exactly to the limit size and it is otherwise satisfactory. Use Plastigauge 12 Type PG-1 for checking bearing surface clearance, e.g. big end bearing shell to crank journal. Instructions for the use of Plastigauge and a scale giving bearing clearances in steps of 0,0025 mm (0.0001 in) are supplied with the package.

On-Board Diagnostics (OBD)

This vehicle uses programmed electronic control systems to provide engine management and emission regulation, automatic transmission operation and anti-lock braking control. These control systems are integral with the On-Board Diagnostics (OBD) facility which is used in conjunction with either the Jaguar approved diagnostic system or the more restricted scan tools.

The OBD information in this manual provides diagnostic and rectification procedures for emission related electrical and mechanical systems. The information is intended to facilitate fault diagnosis and the subsequent rectification of the vehicle without recourse to the Jaguar approved diagnostic system.

The manual covers the following OBD topics:

- General Information
- Engine Management System
- Automatic Transmission
- Anti-lock Braking System

Each section comprises one or more of the following sub-sections as required.

The Description and Operation sub-section includes:

- A general illustration and parts list to help the identification of the particular system or component.
- A brief description of the system operating characteristics and monitoring procedure accompanied by a component illustration.
- Additional information, where appropriate, is provided in the form of component calibrations, characteristics and cross sectional views.
- A localized circuit diagram is included to provide circuit identification, connectors, splices, fuses, wire gauge and colors. See Circuit Diagrams.

The Diagnosis and Testing sub-section is dedicated to fault analysis and rectification, and includes:

- Recommended special tools.
- Symptom chart; a chart containing all relevant Diagnostic Trouble Codes (DTC), their possible causes and an indication of the appropriate test.
- Specific pinpoint test(s), designed so that fault diagnosis can be carried out in a logical and efficient manner.

The Removal and Installation sub-section covers:

- Removal procedure(s), formatted in the recommended sequence.
- Illustrated guide to the use of special tools.
- Illustrations to support the relevant text.
- Installation procedure as above and including special recommendations for processes, lubricants and tightening torques.

Circuit Diagrams

To understand the relationship between the vehicle electrical system and the system circuit diagrams, Refer to the Electrical Guide.

In the interest of clarity, single lines may represent multiple wires. Refer to the color code (1st alpha) followed by the wire reference (numeric/alpha/numeric) to trace origin and destination.

e.g. BW 647B002. BW (black with white trace) 647 (wire reference) B002 (stage from origin).

Glossary of Terms

This glossary of terms is intended to cover mainly emissions-related (to SAE J 1930) terminology, and other abbreviations that may be used in this manual.

The required term may be looked-up in the left-hand column, and subsequent columns give the standard acronym, unit or abbreviation, and definition.

Term(s)	Acronym / Unit / Abbreviation	Definition
Accelerator Pedal	AP	
Accelerator Pedal Position Sensor	APP	Is a multitrack sensor which inputs the drivers demand into the engine control module (ECM)
After Bottom Dead Center	ABDC	Event occurring after BDC
After Top Dead Center	ATDC	Event occurring after TDC
Airbag / Supplementary Restraint System	Airbag, SRS	Airbag restraint system for driver and front seat passenger
Air Cleaner	ACL	
Air Conditioning	A/C	
Air Conditioning Control Module	A/CCM	Module controlling air conditioning, heating and ventilation
Air Conditioning Signal	ACS	Air conditioning compressor clutch operation is signalled to the ECM which induces idle speed corrections to compensate for engine load changes
Alternating current	ac	
Air Fuel Ratio	AFR	Nominally 14.7 parts air to one part fuel
Ampere	A	SI unit of current
Ampere hour	Ah	
ABS Control Module	ABS CM	System which prevents wheel lock-up under braking by sensing lack of rotation of a wheel(s) and diverting fluid pressure away from it (them)
ABS / Traction Control Control Module	ABS/TCCM	System which prevents wheel lock-up under braking by sensing lack of rotation of a wheel(s) and diverting fluid pressure away from it (them)
Atmosphere	atm	Unit of pressure (1.01325 bar)
Barometric Absolute Pressure Sensor	BARO Sensor	Sensor measuring the pressure of surrounding air at any given temperature and altitude
Battery positive voltage	B+	The positive voltage from a battery or any circuit connected directly to it
Before Bottom Dead Center	BBDC	Event occurring before BDC
Before Top Dead Center	BTDC	Event (usually ignition) occurring before TDC
Blower	BLR	Device which supplies a current of air at moderate pressure, e.g. heater or A/C blower
Body Processor Module	BPM	Control module for body electrical systems, e.g. interior lamps, windshield wash / wipe control
Bottom Dead Center	BDC	Lowest point of piston travel in a reciprocating engine
Brake horsepower	BHP	Effective horsepower developed by an engine or motor, as measured by a brake applied to its output shaft
Brake Mean Effective Pressure	BMEP	The part of the effective pressure developed in a cylinder that would result in a cylinder output equal to the bhp of the engine
Brake On/Off	BOO	Indicates the position of the brake pedal
British Standard	BS	Standard specification issued by the British Standards Institution
British Standard Automotive	BSau	
Bus	Topology of a communication network	
Bypass Air	BPA	Mechanical control of throttle bypass air
Camshaft Position Sensor	CMP Sensor	Indicates camshaft position
Canadian Motor Vehicle Safety Standard	CMVSS	
Canister Purge	CANP	Controls purging of the EVAP canister
Carbon dioxide	CO ₂	Colorless gas with a density of approximately 1.5 times that of air
Carbon monoxide	CO	Poisonous gas produced as the result of incomplete combustion
Case Ground	CSE GND	Control module casing ground
Catalytic converter		In-line exhaust system device used to reduce the level of engine exhaust emissions

Celsius	C	SI term for the Centigrade scale, with freezing point at zero and boiling point at 100 degrees
Central Processor Unit	CPU	The section of a computer that contains the arithmetic, logic and control circuits. It performs arithmetic operations, controls instruction processing, and provides timing signals and other housekeeping operations
Cylinder Head Temperature Sensor	CHT Sensor	A sensor for measuring the temperature of the cylinder head
Closed Loop	CL	
Closed Loop System	CL System	Control system with one or more feedback loops
Column/Mirror Control Module	C/MCM	A self-contained group of electrical /electronic components, designed as a single replaceable unit, and controlling one or more processes
Controller Area Network	CAN	A communication system which allows control modules to be linked together.
Crankshaft Position Sensor	CKP Sensor	Generates crankshaft position information in conjunction with the CKPTR (also generates speed information in certain applications)
Crankcase Ventilation System	CV	System which scavenges camshaft cover and crankcase emissions and feeds them into the inlet manifold
Cubic centimeter	cm ³	
Curb weight		Weight of vehicle with fuel, lubricants and coolant, but excluding driver, passengers or payload
Data Link Connector	DLC	Connector providing access and/or control of the vehicle information, operating conditions, and diagnostic information
Data Output Line	DOL	Circuit that sends certain information from the ECM to the instrument cluster
Degree	deg, °	Angle or temperature
Department of Transportation (US)	DOT	Which is a fibre optic ring network, can be diagnosed through the SCP network, and with the optical bus tester.
Deutsche Institut fur Normung	DIN	German standards regulation body
Diagnostic Module	DM	Supplemental Restraint System (non -controlling) module for diagnostics overview
Diagnostic Test Mode	DTM	A level of capability in an OBD system. May include different functional states to observe signals, a base level to read DTCs, a monitor level which includes information on signal levels, bi-directional control with on/off board aids, and the ability to interface with remote diagnosis
Diagnostic Trouble Code	DTC	An alpha/numeric identifier for a fault condition identified by the On-Board Diagnostic (OBD) system
Differential pressure		Pressure difference between two regions e.g. between intake manifold and atmospheric pressures
Differential Pressure Feedback EGR	DPFE	An EGR system that monitors differential EGR pressure across a remote orifice to control EGR flow
Direct current	dc	Current which flows in one direction only, though it may have appreciable pulsations in its magnitude
Domestic Data Bus	D2B	
Exhaust Gas Recirculation Temperature Sensor	EGRT	Sensing EGR function based on temperature change
Engine Management System	EMS	The engine management system conditions and reads inputs, supplies processing capability, and provides output drivers to control actuators as directed by software and calibration
Engine Oil Pressure	EOP	
EGR Vacuum Regulator	EVR	Controls EGR flow by changing vacuum to the EGR valve
EGR Valve Position	EVP	An EGR system that directly monitors EGR valve position to control EGR flow
Electrically Erasable Programmable Read-Only Memory	EEPROM	
Electrically Programmable Read-Only memory	EPROM	
Electronic Secondary Air Injection	EAIR	A pump-driven system for providing secondary air using an electric air pump
Engine Control Module	ECM	
Engine Coolant Level	ECL	
Engine Coolant Temperature	ECT	
ECT Sensor	ECTS	Thermistor which provides engine coolant temperature signal to the ECM to trigger enrichment circuits which increase injector 'on' time for cold start and warm-up
Engine speed	RPM	

Environmental Protection Agency	EPA	
Evaporative Emission	EVAP	System designed to prevent fuel vapor from escaping into the atmosphere. Typically includes a charcoal filled canister to absorb fuel vapor
Evaporative Emission Control Valve	EVAPP	
Exhaust Gas Recirculation	EGR	System which reduces NOx emissions by adding exhaust gases to the incoming fuel/air charge
Exhaust Gas Recirculation Solenoid Vacuum Valve	EGRS	
Exhaust Gas Recirculation Temperature Sensor	EGRT Sensor	
Exhaust Gas Recirculation Valve	EGR Valve	
Fan Control	FC	Engine cooling fan control
Federal Motor Vehicle Safety Standard (US)	FMVSS	
Figure	Fig.	Illustration reference
Flash Electrically Erasable Programmable Read-Only Memory	FEEPROM	
Flash Erasable Programmable Read-Only Memory	FEPROM	
Flywheel Sensor	CKFS	Sensor mounted so as to be triggered by each flywheel ring gear tooth to give an engine speed signal
Fuel Injection	FI	Solenoid operated devices that spray a metered quantity of fuel into the inlet ports
Fuel Pressure Regulator Control	FPRC	Controls fuel pressure regulator; used primarily to give extra fuel at cold start-up
Fuel Pump	FP	Pumps fuel from the fuel tank to the fuel injection system
Fuel Pump Monitor	FP Module	Monitors operation of fuel pump
Fuel Pump Relay	FP Relay	Relay which controls electrical current to fuel pump
Fuel rich/lean		Qualitative evaluation of air/fuel ratio based on a ratio known as stoichiometry, or 14.7:1 (Lambda)
Generic Electronic Module	GEM	
Generator	GEN	Rotating machine which converts mechanical energy into electrical energy
Gramme centimeter	gcm	
Gramme (force)	gf	
Gramme (mass)	g	
Ground	GND	Electrical conductor used as a common return for an electrical circuit or circuits, and with a relative zero potential
Hard fault		A fault currently present in the system
Headlamp	HL	
Heated Oxygen Sensor	HO2S	Electrically heated oxygen sensor which induces fueling corrections
Hertz (frequency)	Hz	Frequency, one cycle per second
High Mounted Stoplamp	HMSL	
High tension	HT	
Hour	hour	
Hydrocarbon	HC	
Idle Air Control	IAC	Stepper motor driven device which varies the volume of air by-passing the throttle to maintain the programmed idle speed
Ignition amplifier	IA	Device which amplifies the ignition system output
Ignition ground	IGN GND	
Injection Pressure Sensor	IPS	
Inertia Fuel Shut-off	IFS	An inertia system that shuts off the fuel supply when activated by pre-determined force limits brought about by (e.g.) collision
Inertia Fuel Shut-off Switch	IFS Switch	Shuts down fuel and ignition systems in the event of a vehicle impact
Intake air		Air drawn through a cleaner and distributed to each cylinder for use in combustion
Intake Air Temperature	IAT	Temperature of intake air
Intake Air Temperature Sensor	IAT Sensor	Device used to measure IAT

Intake Air Temperature Sensor Ignition	IAT Sensor Ignition	Thermistor which signals the ECM to retard the ignition timing in response to high inlet air temperatures
Intake Air Temperature Sensor Injection	IAT Sensor Injection	Thermistor which inputs air density information to the ECM
Internal diameter	i.dia	
International Standards Organisation	ISO	
Kilogramme (mass)	kg	
Kilogramme (force)	kgf	
Kilogramme force per square centimeter	kgf/cm ²	
Kilometer	km	
Kilometer per hour	km/h	
Kilopascal	kPa	
Kilovolt	kV	
Knock Sensor	KS	Sensor which detects the onset of detonation, and signals the ECM to retard the ignition
Left-hand	LH	
Left-hand drive vehicle	LHD	
Left-hand thread	LHthd	
Liquid Crystal Display	LCD	Optical digital display system, applied voltage to which varies the way the crystals reflect light, thereby modifying the display
Litre	L	
Low Tension	LT	Primary circuit of the ignition system, linking the battery to the primary winding in the ignition coil
Malfunction Indicator Lamp	MIL	A required on-board indicator to alert the driver of an emission related malfunction
Manifold Absolute Pressure	MAP	Absolute pressure of the intake manifold air
Manifold Absolute Pressure Sensor	MAP Sensor	Sensor located in the ECM and ported to the intake manifold
Manifold Surface Temperature	MST	
Mass Air Flow	MAF	System which provides information on the mass flow rate of the intake air to the engine
Mass Air Flow Sensor	MAF Sensor	Hot-wire sensor which monitors air flow into the intake manifold for fueling and ignition control
Maximum	max.	
Meter (measurement)	m	
Metric (screw thread, e.g. M8)	M	
Microfarad	MFD	Unit of electrical capacitance, one millionth of a farad
Millimeter	mm	
Millimeter of mercury	mmHg	
Millisecond	ms	
Minimum	min.	
Minute	minute	
Model year	MY	
Motorized In-Car Aspirator	MIA	Device which constantly samples cabin temperature by passing air over a sensor, and communicates with the A/CCM to modify A/C system performance to suit
Multi Protocol Adapter	MPA	An interpreter for the various data languages present on a vehicle
National Institute of Occupational Safety and Health (US)	NIOSH	
Newton	N	SI unit of force. 1 N = 0.2248 pounds force
Newton Meter	Nm	SI unit of torque. Must not be confused with nm (nanometer)
Nox		Compounds of nitrogen and oxygen formed at high temperatures. Major source of exhaust-gas air pollution
Non-Volatile Random Access Memory	NVRAM	RAM which retains memory even if power supply is interrupted
Normally aspirated	N/A	Fueling system using intake air at atmospheric pressure; not supercharged or turbocharged
Normally Closed	NC	
Normally Open	NO	

North American Specification	NAS	Vehicles for sale in the USA and Canadian markets
Number	No.	
Occupational Safety and Health Administration (US)	OSHA	
On-Board Diagnostic	OBD	A system that monitors some or all computer input and output control signals. Signal(s) outside the pre-determined limits imply a fault in the system or a related system
Original Equipment Manufacturer	OEM	
Outside Diameter	o. dia	
Oxides of nitrogen	Nox	
Oxygen Sensor	O2S	A sensor which detects oxygen content in the exhaust gases
Parameter Identification	PID	An index number referring to a parameter within a module without knowledge of its storage location
Park Neutral Position	PNP	
Park Neutral Position Switch	PNP Switch	Indicates the selected non-drive modes of the (automatic) transmission
Part number	part no.	
Pulse Width Modulated	PWM	
Programmable Electronic Control Units System	PECUS	Process whereby a common ECM is programmed on the production line to suit the market requirements of a particular vehicle
Programmable Read-only Memory	PROM	ROM with some provision for setting the stored data after manufacture
Random Access Memory	RAM	Fast access memory store which is accessible for entry or extraction of data
Read-Only Memory	ROM	Fast access memory in which data is fixed and may not be changed
Reservoir	RES	Container, usually for oils, coolants or hydraulic fluids
Rest Of The World	ROW	
Return	RTN	A dedicated sensor ground circuit
Revolutions Per Minute	RPM	Shaft speed of a device, usually an engine or motor
Right-hand	RH	
Right-hand drive	RHD	
Scan Tool	ST	Device that interfaces with and communicates information on a data link
Seat Control Module	SCM	Module controlling the seat motor systems (not electric raise/lower-only seats)
Secondary Air		Air provided to the exhaust system
Secondary Air	AIR	System used for a period of time each time the engine is started, unless certain temperature criteria are met. Pumps air directly into the exhaust system which generates extra heat and reduces the time taken for the catalytic converters to reach operating temperature
Secondary Air Injection Bypass	AIR Bypass	Vents secondary air to atmosphere
Secondary Air Injection Check Valve	AIR Check Valve	Valve which prevents back-flow of exhaust gas to the AIR system when the system is inoperative
Secondary Air Injection Diverter	AIR Diverter	Diverts secondary air to either the catalyst or exhaust manifold
Secondary Air Injection Magnetic Clutch	AIR Clutch	Clutch mounted on the AIRP drive shaft
Secondary Air Injection Pump	AIR Pump	Mechanically driven rotary vane pump, driven through the AIRPC
Secondary Air Injection Relay	AIR Relay	Controls the injection of air into the exhaust system
Secondary Air Injection Switching Valve	AIR Switching Valve	Vacuum operated valve backing-up the AIRC
Security & Locking Control Module	SLCM	Module controlling the vehicle's security and closure-locking functions
Sensor	S	Generic name for a device that senses either the absolute value or a change in a physical quantity such as temperature, pressure or flow rate, and converts that change into an electrical quantity signal
Service Repair Operation (number)	SRO	Number generated by Jaguar Methods & Techniques system which relates to the time allowed to complete a repair operation. Further information on the system can be found in the separate Jaguar Publications (for each model range) entitled 'Repair Operation Times'
Shift Solenoid	SS	Controls shifting in an automatic transmission
Signal return	SIG RTN	

Sliding Roof Control Module	SRCM	
Society of Automotive Engineers	SAE	
Speed Control Control Module	SCCM	Module controlling Speed Control System
Square centimeter	cm ²	
Standard	std	
Standard Corporate Protocol	SCP	A high-speed, serial communications system linking all body system control modules. Control messages and data are passed between modules at up to 786 messages per second
Supercharger	SC	An intake system which utilizes a supercharger (mechanically driven device that pressurizes intake air, thereby increasing density of charge air and the consequent power output from a given displacement)
Supercharger Bypass	SCB	
Tachometer	TACH	A circuit that provides input for an electronic tachometer display
Thermal Vacuum Valve	TVV	Controls vacuum levels or routing based on temperature
Throttle Body	TB	Device containing the throttle
Throttle Position	TP	
Throttle Position Sensor	TP Sensor	Interprets throttle position and movement to identify idle, acceleration and full-power demands
Throttle Manifold Absolute Pressure Sensor	TMAP	Combines the inlet air temperature and manifold pressure sensor in one component
Top Dead Center	TDC	
Torque Converter Clutch	TCC	
Transmission Control Module	TCM	Controls the shifting pattern of the (automatic) transmission
Transmission Control Switch	TCS	Modifies the operation of electronically controlled transmissions
Transmission Oil Temperature	TOT	Indicates temperature of transmission fluid
Transmission Range	TR	The range in which the transmission is operating
Turbine Shaft Speed	TSS	Indicates rotational speed of transmission output shaft or turbine shaft
Vacuum Solenoid Valve	VSV	Vacuum operated valve used in the speed control system
Vacuum Solenoid Valve (atm)	VSV(VA)	Vacuum atmospheric valve used in the speed control system
Vacuum Solenoid Valve (rel)	VSV(VR)	Vacuum release valve used in the speed control system
Vacuum Solenoid Valve (vac)	VSV(VV)	Vacuum valve used in the speed control system
Variable Valve Timing	VVT	A system by which the relationship of the crankshaft and camshaft may be altered during engine running
Vehicle Battery Adapter	VBA	Provides electrical power to the Jaguar approved diagnostic system and supplies a battery reference level
Vehicle Control Monitor	VCM	Instrument panel display which warns of faults
Vehicle Emission Control Information Label	VECI Label	
Vehicle Identification Number	VIN	Number assigned to the vehicle by the manufacturer, primarily for licensing and identification purposes
Vehicle Interface Adapter	VIA	Extends the Jaguar approved diagnostic system capability and provides a parallel interface to vehicle harnesses and ECMs
Vehicle Speed Sensor	VSS	Sensor which provides vehicle speed information
Viscosity Index	VI	
Voltage Regulator	VR	Device which regulates the variable output voltage of a generator
Watt	W	SI unit of power (1 hp = 745.7 watts)
Wide Open Throttle	WOT	Full throttle position

Health and Safety Precautions

Prolonged and repeated contact with mineral oil will result in the removal of natural oils from the skin, leading to dryness, irritation and dermatitis. In addition, used engine oil contains potentially harmful contaminants which may cause skin cancer. Washing facilities and adequate means of skin protection should be provided.

Observe these recommendations:

- Wear protective clothing, including impervious gloves where practicable.
- Do not put oily rags in pockets. Avoid contaminating clothes, particularly underwear, with oil.
- Overalls must be cleaned regularly. Discard oil impregnated clothing and footwear which cannot be washed or cleaned.
- First Aid treatment should be obtained immediately for open cuts or wounds.
- Use barrier creams, applying before each work period, to enable easier removal of dirty oil and grease from the skin.
- Wash with soap and water to make sure that all oil is removed (skin cleaner and a nail brush will help). The use of preparations containing lanolin will help to replace the natural skin oils which have been removed.
- Do not use petrol, kerosene, gas oil, thinners or solvents for washing skin.
- If skin disorders develop, obtain medical advice immediately.
- Where practical, degrease components prior to handling.
- Where there is a risk of fluids coming into contact with the eyes, eye protection should be worn, for example, goggles or a face shield. An eye wash facility should be provided.

The Health and Safety Precautions subsection refers to some commonly used chemicals and materials, hazards associated with their use, and safety measures to be taken. Some of these chemicals may be included in the following list either in their own right or as an ingredient in a sealer or adhesive.

Acids and Alkalis

See also Battery Acids.

e.g. caustic soda, sulphuric acid.

Used in batteries and cleaning materials.

Irritant and corrosive to the skin, eyes, nose and throat. Cause burns. Can destroy ordinary protective clothing.

Avoid splashes to the skin, eyes and clothing. Wear suitable protective impervious apron, gloves and goggles. Do not breath mists.

Ensure access to eye wash bottles, shower and soap are readily available for splashing accidents.

Display Eye Hazard sign.

Air Bags

See also Fire, Chemical Materials - General

Highly flammable, explosive – observe No Smoking policy.

Used as a safety restraint system mounted in the steering wheel.

The inflator contains a high - energetic propellant which, when ignited, produces a VERY HOT GAS (2500° C).

The gas generant used in air bags is Sodium Azide. This material is hermetically sealed in the module and is completely consumed during deployment. No attempt should be made to open an air bag inflator as this will lead to the risk of exposure to Sodium Azide. If a gas generator is ruptured, full protective clothing should be worn when dealing with the spillage.

After normal deployment, gloves and safety goggles should be worn during the handling process.

Deployed air bags should be disposed of in a plastic bag in accordance with local regulations at an approved chemical waste site.

Following any direct contact with gas generant.

- Wash affected areas thoroughly with water.
- Seek medical assistance if necessary.

Air Bags - Do's

- Do store in an airbag safe when not fitted to the vehicle.
- Do store modules in an upright position.
- Do keep modules dry.

- Do carry modules with the cover side pointing away from the body.
- Do place modules with their cover side upwards.
- Do carefully inspect modules for damage.
- Do stand to one side when connecting modules.
- Do make sure all test equipment is properly calibrated and maintained.
- Do wash your hands after handling deployed air bags.

Air Bags - Do Nots

- Do not store highly flammable material together with modules or gas generators.
- Do not store gas generators at temperatures exceeding 80° C.
- Do not store modules upside down.
- Do not attempt to open a gas generator housing.
- Do not expose gas generators to open flame or sources of heat.
- Do not place anything on top of a module cover.
- Do not use damaged modules.
- Do not touch a fired module or gas generator for at least 10 minutes.
- Do not use any electrical probes on the wiring circuit.

Air Conditioning Refrigerant

See also Chlorofluorocarbon, Chemical Materials

Highly flammable, combustible – observe No Smoking policy.

Skin contact may result in frostbite.

Instructions given by the manufacturer must be followed. Avoid naked lights, wear suitable protective gloves and goggles.

If refrigerant comes into contact with the skin or eyes, rinse the affected areas with water immediately. Eyes should also be rinsed with an appropriate irrigation solution and should not be rubbed. SEEK MEDICAL ASSISTANCE IF NECESSARY.

Air Conditioning Refrigerant - Do Nots

- Do not expose refrigerant bottles to sunlight or heat.
- Do not stand refrigerant bottles upright; when filling, hold them with the valve downwards.
- Do not expose refrigerant bottles to frost.
- Do not drop refrigerant bottles.
- Do not vent refrigerant to atmosphere under any circumstance.
- Do not mix refrigerants i.e. R12 (Freon) and R134a.

Antifreeze

See also Fire, Solvents.

e.g. isopropanol, ethylene glycol, methanol.

Highly flammable, flammable, combustible.

Used in vehicle coolant systems, brake air pressure systems, screenwash solutions.

Vapors may be given off from coolant antifreeze (glycol) when heated. Avoid breathing these vapors.

Antifreeze may be absorbed through the skin in toxic or harmful quantities. Antifreeze, if swallowed can be fatal and medical attention should be sought immediately.

These products must not be used in any cooling or industrial water system which is connected or linked to general, food preparation or drinking water supplies.

Asbestos

Used in brake and clutch linings, transmission brake bands and gaskets. Jaguar original production and replacement items are asbestos free.

See also Warning Symbols on Vehicles at the end of this subsection.

Breathing asbestos dust may cause lung damage or, in some cases, cancer.

The use of drum cleaning units, vacuum cleaning or damp wiping is preferred.

Asbestos dust waste should be dampened, placed in a sealed container and marked to make sure safe disposal. If any cutting or drilling is attempted on materials containing asbestos the item should be dampened and only hand tools or low speed power tools used.

Battery Acids

See also Acids and Alkalis.

Gases released during charging are explosive. Never use naked flames or allow sparks near charging or recently charged batteries.

Ensure adequate ventilation.

Brake and Clutch Linings and Pads

See Asbestos.

Brakes Fluids (Polyalkylene Glycols)

See also Fire.

Splashes to the skin and eyes may cause irritation. Avoid skin and eye contact as far as possible. Inhalation vapor hazards do not arise at ambient temperatures because of the very low vapor pressure.

Brazing

See Welding.

Chemical Materials

See also Legal Aspects.

Chemical materials such as solvents, sealers, adhesives, paints, resin foams, battery acids, antifreeze, brake fluids, fuels, oils and grease should always be used with caution and stored and handled with care. They may be toxic, harmful, corrosive, irritant or highly flammable and give rise to hazardous fumes and dusts.

The effects of excessive exposure to chemicals may be immediate or delayed; briefly experienced or permanent; cumulative; superficial; life threatening; or may reduce life - expectancy.

Chemical Materials - Do's

- Do carefully read and observe hazard and precaution warnings given on material containers (labels) and in any accompanying leaflets, posters or other instructions. Material health and safety data sheets can be obtained from manufacturers.
- Do remove chemical materials from the skin and clothing as soon as practical after soiling. Change heavily soiled clothing and have it cleaned.
- Do organise work practices and protective clothing to avoid soiling of the skin and eyes, breathing vapors, aerosols, dusts or fumes, inadequate container labelling fire and explosion hazards.
- Do wash before breaks, before eating, smoking, drinking or using toilet facilities when handling chemical materials.
- Do keep work areas clean, uncluttered and free of spills.
- Do store chemical materials according to national and local regulations.
- Do keep chemical materials out of the reach of children.

Chemical Materials - Do Nots

- Do not mix chemical materials except under the manufacturer's instructions; some chemicals can form other toxic or harmful chemicals, give off toxic or harmful fumes or become explosive when mixed together.
- Do not spray chemical materials, particularly those based on solvents, in confined spaces e.g. when people are inside a vehicle.
- Do not apply heat or flame to chemical materials except under the manufacturer's instructions. Some are highly flammable and some may release toxic or harmful fumes.
- Do not leave containers open. Fumes given off can build up to toxic, harmful or explosive concentrations. Some fumes are heavier than air and will accumulate in confined areas, pits etc.
- Do not transfer chemical materials to unlabeled containers.
- Do not clean hands or clothing with chemicals. Chemicals, particularly solvents and fuels, will dry skin and may cause irritation leading to dermatitis or be absorbed through the skin in toxic or harmful quantities.
- Do not use emptied containers for other materials except when they have been cleaned under supervised conditions.
- Do not sniff or smell chemical materials. Brief exposure to high concentrations of fumes can be toxic or harmful.

Chlorofluorocarbons (CFC)

There is concern in the scientific community that CFCs and Halons are depleting the upper ozone layer which filters out harmful ultraviolet radiation. Decreased filtration of ultraviolet radiation may result in increases in skin cancer, cataracts and immune system suppression in humans, as well as decreased productivity of crops and aquatic systems.

CFCs are used primarily as refrigerants in vehicle air conditioning systems and as aerosol propellants. Halons are used as fire extinguishants.

Jaguar supports worldwide elimination of CFC usage and it is recommended that Company subsidiaries and affiliates should phase out CFC usage as soon as acceptable substitutes are commercially available.

Clutch Fluids

See Brake fluids.

Clutch Linings and Pads

See Asbestos.

Corrosion Protection Materials

See also Solvents, Fire.

Highly flammable, flammable – observe No Smoking policy.

These materials are varied and the manufacturer's instructions should be followed. They may contain solvents, resins, petroleum products etc. Skin and eye contact should be avoided. They should only be sprayed in conditions of adequate ventilation and not in confined spaces.

Cutting

See Welding.

Dewaxing

See Solvents and Fuels (Kerosene).

Dusts

Powder, dusts or clouds may be irritant, harmful or toxic. Avoid breathing dusts from powdery chemical materials or those arising from dry abrasion operations. Wear respiratory protection if ventilation is inadequate.

Fine dusts of combustible material can present an explosion hazard. Avoid explosive limits and/or sources of ignition.

Electric Shock

Electric shock can result from the use of faulty electrical equipment or from the misuse of equipment in good condition.

Ensure that electrical equipment is maintained in good condition and frequently tested. Faulty equipment should be labelled and preferably removed from the work station.

Ensure that flexes, cables, plugs and sockets are not frayed, kinked, cut, cracked or otherwise damaged.

Ensure that electrical equipment and flexes do not come into contact with water.

Ensure that electrical equipment is protected by the correct rated fuse.

Never misuse electrical equipment and never use equipment which is in any way faulty. The results could be fatal.

Ensure that the cables of mobile electrical equipment cannot get trapped and damaged, such as in a vehicle hoist.

Ensure that the designated electrical workers are trained in basic First Aid.

In cases of electrocution:

- Switch off the power supply before approaching the victim.
- If this is not possible push or drag the victim from the source of electricity using dry non - conductive material.
- Commence resuscitation if trained to do so.
- SUMMON MEDICAL ASSISTANCE.

Engine Oils

See Lubricants and Grease.

Exhaust Fumes

These contain asphyxiating, harmful and toxic chemicals and particles such as carbon oxides, nitrogen oxides, aldehydes, lead and aromatic hydrocarbons. Engines should be run only under conditions of adequate exhaust extraction or general ventilation and not in confined spaces.

Gasolene (petrol) engine

There may not be adequate warning of odour or of irritation before toxic or harmful effects arise. These may be immediate or delayed.

Fibre Insulation

See also Dusts.

Used in noise and sound insulation.

The fibrous nature of surfaces and cut edges can cause skin irritation. This is usually a physical and not a chemical effect.

Precautions should be taken to avoid excessive skin contact through careful organization of work practices and the use of gloves.

Fire

See also Welding, Foams, Legal Aspects.

Many of the materials found on or associated with the repair of vehicles are highly flammable. Some give off toxic or harmful fumes if burnt.

Observe strict fire safety when storing and handling flammable materials or solvents, particularly near electrical equipment or welding processes.

Ensure, before using electrical or welding equipment, that there is no fire hazard present.

Have a suitable fire extinguisher available when using welding or heating equipment.

First Aid

Apart from meeting any legal requirements it is desirable for someone in the workshop to be trained in First Aid procedures.

Splashes in the eye should be flushed carefully with clean water for at least ten minutes.

Soiled skin should be washed with soap and water.

Individuals affected by inhalation of gases, fumes etc. should be removed to fresh air immediately. If effects persist, consult a doctor.

If liquids are swallowed inadvertently, consult a doctor giving him the information on the container or label. Do not induce vomiting unless this action is indicated on the label.

Fluoroelastomer

See Viton.

Foams - Polyurethane

See also Fire.

Used in sound and noise insulation. Cured foams used in seat and trim cushioning.

Follow manufacturer's instructions.

Unreacted components are irritating and may be harmful to the skin and eyes. Wear gloves and goggles.

Individuals with chronic respiratory diseases, asthma, bronchial medical problems, or histories of allergic diseases should not work in or near uncured materials.

The components, vapors or spray mists can cause direct irritation, sensitivity reactions and may be toxic or harmful.

Vapors and spray mists must not be inhaled. These materials must be applied with adequate ventilation and respiratory protection. Do not remove the respirator immediately after spraying, wait until the vapor/mists have cleared.

Burning of the uncured components and the cured foams can generate toxic and harmful fumes. Smoking, naked flames or the use of electrical equipment during foaming operations and until vapors/mists have cleared should not be allowed. Any heat cutting of cured foams or partially cured foams should be conducted with extraction ventilation.

Freon

See Air Conditioning Refrigerant.

Fuels

See also, Fire, Legal Aspects, Chemicals and Solvents.

Avoid skin contact with fuel where possible. Should contact occur, wash the affected skin with soap and water.

Gasoline (Petrol)

Highly flammable - observe No Smoking policy.

Swallowing can result in mouth and throat irritation and absorption from the stomach can result in drowsiness and unconsciousness. Small amounts can be fatal to children. Aspiration of liquid into the lungs e.g. through vomiting, is a very serious hazard.

Gasoline dries the skin and can cause irritation and dermatitis on prolonged or repeated contact. Liquid in the eye causes severe pain.

Motor gasoline may contain appreciable quantities of benzene, which is toxic upon inhalation, and the concentration of gasoline vapors must be kept very low. High concentrations will cause eye, nose and throat irritation, nausea, headache, depression and symptoms of drunkenness. Very high concentrations will result in rapid loss of consciousness.

Ensure there is adequate ventilation when handling and using gasoline. Great care must be taken to avoid the serious consequences of inhalation in the event of vapor build up arising from spillages in confined spaces.

Special precautions apply to cleaning and maintenance operations on gasoline storage tanks.

Gasoline should not be used as a cleaning agent. It must not be siphoned by mouth. See First Aid.

Gas - oil (Diesel Fuel)

See warnings and cautions in relevant manual sections.

Combustible.

Gross or prolonged skin contact with high boiling point gas oils may also cause serious skin disorders including skin cancer.

Kerosene (Paraffin)

Used also as heating fuel, solvent and cleaning agent.

Flammable - observe No Smoking policy.

Irritation of the mouth and throat may result from swallowing. The main hazard from swallowing arises if liquid aspiration into the lungs occurs.

Liquid contact dries the skin and can cause irritation or dermatitis. Splashes in the eye may be slightly irritating.

In normal circumstances the low volatility does not give rise to harmful vapors. Exposure to mists and vapors from kerosene at elevated temperature should be avoided (mists may arise in dewaxing). Avoid skin and eye contact and make sure there is adequate ventilation.

Gas Cylinders

See also Fire.

Gases such as oxygen, acetylene, argon and propane are normally stored in cylinders at pressures of up to 13.790 kPa, (2000 lb/in²) and great care should be taken in handling these cylinders to avoid mechanical damage to them or to the valve gear attached. The contents of each cylinder should be clearly identified by appropriate markings.

Cylinders should be stored in well ventilated enclosures, and protected from ice and snow, or direct sunlight. Fuel gases (e.g. acetylene and propane) should not be stored in close proximity to oxygen cylinders.

Care should be exercised to prevent leaks from gas cylinders and lines, and to avoid sources of ignition.

Only trained personnel should undertake work involving gas cylinders.

Gases

See Gas Cylinders.

Gaskets (Fluoroelastomer)

See Viton.

General Workshop Tools and Equipment

It is essential that all tools and equipment are maintained in good condition and the correct safety equipment is used where required.

Never use tools or equipment for any purpose other than that for which they were designed. Never over – load equipment such as hoists, jacks, axle and chassis stands or lifting slings. Damage caused by overloading is not always immediately apparent and may result in a fatal failure the next time that the equipment is used.

Do not use damaged or defective tools or equipment, particularly high speed equipment such as grinding wheels. A damaged grinding wheel can disintegrate without warning and cause serious injury.

Wear suitable eye protection when using grinding, chiselling or sand blasting equipment.

Wear a suitable breathing mask when using abrasive blasting equipment, working with asbestos-based materials or using spraying equipment.

Ensure adequate ventilation to control dusts, mists and fumes.

High Pressure Air, Lubrication and Oil Test Equipment

See also Lubricants and Greases.

Always keep high pressure equipment in good condition, and regularly maintained, particularly at joints and unions.

Never direct a high pressure nozzle, e.g. diesel injector, at the skin as the fluid may penetrate to the under - lying tissue etc., and cause serious injury.

Halon

See CFCs.

Legal Aspects

Many laws and regulations make requirements relating to health and safety in the use and disposal of materials and equipment in workshops. Some of these laws which apply in the U.K. are listed. Similar laws exist for other territories:

- The Factories Act (1961).
- The Asbestos Regulations (1969).
- Highly Flammable Liquids and Liquefied Petroleum Gases Regulations (1972).
- Control of Pollution Act (1974).
- Health and Safety at Work Act (1974).
- The Classification, Packaging and Labelling of Dangerous Substances Regulations (1978, 1981, 1983, 1984).
- Control of Lead at Work Regulations (1980).
- Control of Substances Hazardous to Health (COSHH) Regulations (1989).
- Abrasive Wheels Regulations (1970).
- Reporting of injuries, diseases and dangerous occurrences regulations 1985 (RIDDOR).

Workshops should be familiar, in detail, with these and associated laws and regulations.

Consult the local factory inspectorate if in any doubt.

Lubricants and Greases

Avoid all prolonged and repeated contact with mineral oils. All lubricants and greases may be irritating to the eyes and skin.

Used Engine Oil

Prolonged and repeated contact with mineral oil will result in the removal of natural oils from the skin, leading to dryness, irritation and dermatitis. In addition, used engine oil contains potentially harmful contaminants which may cause skin cancer. Adequate means of skin protection and washing facilities must be provided.

Do not employ used engine oils as lubricants or for any application where appreciable skin contact is likely to occur.

There are publications describing the problems and advising on precautionary measures. For the UK a typical Health and Safety Executive publication is: SHW 397: Cautionary Notice: Effects of mineral oil on the skin.

Health Protection Precautions

- Avoid prolonged and repeated contact with oils, particularly used engine oils.
- Wear protective clothing, including impervious gloves where practicable.
- Do not put oily rags into pockets.
- Avoid contaminating clothing.
- Heavily soiled clothing and oil - impregnated footwear should not be worn. Overalls must be cleaned regularly.
- First Aid treatment should be obtained immediately for open cuts and wounds.
- Use barrier creams, applying them before each work period, to help the removal of oil from the skin.
- Wash with soap and water to make sure all oil is removed (skin cleansers and nail brushes will help). Preparations containing lanoline replace the natural skin oils which have been removed.
- Do not use gasoline (petrol), kerosene (paraffin), diesel fuel (gas oil), thinners or solvents for cleaning skin.
- If skin disorders develop, obtain medical advice without delay.
- Where practical, degrease components prior to handling.
- Where there is a risk of eye contact, eye protection should be worn, for example, chemical goggles or face shields; in addition an eye wash facility should be provided.

Environmental Precautions

Burning used engine oil in small space heaters or boilers can be recommended only for units of approved design. In the UK the heating system must meet the requirements of HM Inspectorate of Pollution for small burners of less than 0.4 MW. If in doubt check with the appropriate local authority and/or manufacturer of approved appliances.

Dispose of used oil and used oil filters through authorized waste disposal contractors or licensed waste disposal sites, or to the waste oil reclamation trade, batteries should also be disposed off under similar arrangements. If in doubt, contact the relevant local authority for advice on disposal facilities.

It is illegal to pour used oil, antifreeze and automatic transmission fluid on to the ground, down sewers, drains, or into water courses.

Noise

Some operations may produce high noise levels which could, in time, damage hearing. In these cases, suitable ear protection must be worn.

Noise Insulation Materials

See Foams, Fibre Insulation.

O-Rings (Fluoroelastomer)

See Viton.

Paints

See also body and paint manual.

See also Solvents, Chemical Materials.

Highly flammable, flammable - observe No Smoking policy

Pressurized Equipment

See High Pressure Air, Lubrication and Oil Test Equipment.

Solder

Solders are mixtures of metals such that the melting point of the mixture is below that of the constituent metals (normally lead and tin). Solder application does not normally give rise to toxic lead fumes, provided a gas/air flame is used. Oxy - acetylene flames should not be used, as they are much hotter and will cause lead fumes to be produced.

Some fumes may be produced by the application of any flame to surfaces coated with grease etc. and inhalation of these should be avoided.

Removal of excess solder should be undertaken with care, to make sure that fine lead dust is not produced, which can give toxic effects if inhaled. Respiratory protection may be necessary.

Solder spillage and filings should be collected and removed promptly to prevent general air contamination by lead.

High standards of personal hygiene are necessary in order to avoid ingestion of lead or inhalation of solder dust from clothing.

Solvents

See also Chemical Materials, Fuels (Kerosene), Fire.

e.g. acetone, white spirit, toluene, xylene, trichloroethane.

Used in cleaning and dewaxing materials, paints, plastics, resins, thinners etc.

Some may be highly flammable or flammable.

Skin contact will degrease the skin and may result in irritation and dermatitis following repeated or prolonged contact. Some can be absorbed through the skin in toxic or harmful quantities.

Splashes in the eye may cause severe irritation and could lead to loss of vision.

Brief exposure of high concentrations of vapors or mists will cause eye and throat irritation, drowsiness, dizziness, headaches and, in the worst circumstances, unconsciousness.

Repeated or prolonged exposure to excessive but lower concentrations of vapors or mists, for which there might not be adequate warning indications, can cause more serious toxic or harmful effects.

Aspiration into the lungs (e.g. through vomiting) is the most serious consequence of swallowing.

Avoid splashes to the skin, eyes and clothing. Wear protective gloves, goggles and clothing if necessary.

Ensure good ventilation when in use, avoid breathing fumes, vapors and spray mists and keep containers tightly sealed. Do not use in confined spaces.

When spraying materials containing solvents, e.g. paints, adhesive, coatings, use extraction ventilation or personal respiratory protection in the absence of adequate general ventilation.

Do not apply heat or flame except under specific and detailed manufacturer's instructions.

Sound Insulation

See Fibre Insulation, Foams.

Suspended Loads



CAUTION: Never improvise lifting tackle.

There is always a danger when loads are lifted or suspended. Never work under an unsupported, suspended or raised load e.g. suspended engine, etc.

Always make sure that lifting equipment such as jacks, hoists, axle stands, slings, etc., are adequate and suitable for the job, in good condition and regularly maintained.

Transmission Brake Bands

See Asbestos.

Underseal

See Corrosion Protection.

Viton

In common with many other manufacturers' vehicles, some components fitted to the Jaguar range have 'O' rings, seals or gaskets which contain a material known as 'Viton'.

Viton is a fluoroelastomer, that is a synthetic rubber type which contains Fluorine. It is commonly used for 'O' rings, gaskets and seals of all types. Although Viton is the most well known fluoroelastomer, there are others, including Fluorel and Tecnoflon.

When used under design conditions fluoroelastomers are perfectly safe. If, however, they are exposed to temperatures in excess of 400° C,

the material will not burn, but will decompose, and one of the products formed is hydrofluoric acid.

This acid is extremely corrosive and may be absorbed directly, through contact, into the body.

'O' rings, seals or gaskets which have been exposed to very high temperatures will appear charred or as a black sticky substance.

DO NOT, under any circumstances touch them or the attached components.

Enquiries should be made to determine whether Viton or any other fluoroelastomer has been used in the affected 'O' ring, seal or gasket. If they are of natural rubber or nitrile there is no hazard. If in doubt, be cautious and assume that the material may be Viton or any fluoroelastomer.

If Viton or any other fluoroelastomers have been used, the affected area should be decontaminated before the commencement of work.

Disposable heavy duty plastic gloves should be worn at all times, and the affected area washed down using wire wool and a limewater (calcium hydroxide) solution to neutralize the acid before disposing of the decomposed Viton residue and final cleaning of the area. After use, the plastic gloves should be discarded carefully and safely.

Welding

See also Fire, Electric Shock, Gas Cylinders.

Welding processes include Resistance Welding (Spot Welding), Arc Welding and Gas Welding.

Resistance Welding

This process may cause particles of molten metal to be emitted at a high velocity, and the eyes and skin must be protected.

Arc Welding

This process emits a high level of ultra - violet radiation which may cause arc - eye and skin burns to the operator and to other persons nearby. Gas - shielded welding processes are particularly hazardous in this respect. Personal protection must be worn, and screens used to shield other people.

CONTACT LENS WEARERS ARE ADVISED TO REVERT TO ORDINARY SPECTACLES WHEN ARC WELDING as the arc spectrum is believed to emit microwaves which dry out the fluid between the lens and the eye. This may result in blindness when the lens is removed from the eye.

Metal spatter will also occur, and appropriate eye and skin protection is necessary.

The heat of the welding arc will produce fumes and gases from the metals being welded, the rods and from any applied coatings or contamination on the surfaces being worked on. These gases and fumes may be toxic and inhalation of these should be avoided. The use of extraction ventilation to remove the fumes from the working area may be necessary particularly in cases where the general ventilation is poor, or where considerable welding work is anticipated. In extreme cases or confined spaces where adequate ventilation cannot be provided, air-fed respirators may be necessary.

Gas Welding (and Cutting)

Oxy - acetylene torches may be used for welding and cutting, and special care must be taken to prevent leakage of these gases, with consequent risk of fire and explosion.

The process will produce metal spatter and eye and skin protection is necessary.

The flame is bright, and eye protection should be used, but the ultra - violet emission is much less than that from arc welding, and lighter filters may be used.

The process itself produces few toxic fumes, but such fumes and gases may be produced from coatings on the work, particularly during cutting away of damaged body parts, and inhalation of the fumes should be avoided.

In brazing, toxic fumes may be produced from the metals in the brazing rod, and a severe hazard may arise if brazing rods containing cadmium are used. In this event particular care must be taken to avoid inhalation of fumes and expert advice may be required.

SPECIAL PRECAUTIONS MUST BE TAKEN BEFORE ANY WELDING OR CUTTING TAKES PLACE ON VESSELS WHICH HAVE CONTAINED COMBUSTIBLE MATERIALS, E.G. BOILING OR STEAMING OUT OF FUEL TANKS.

Warning Symbols on Vehicles

Decals showing warning symbols will be found on various vehicle components.

These decals must not be removed. The warnings are for the attention of owners/operators and persons carrying out service or repair operations on the vehicle.

The most commonly found decals are reproduced below together with an explanation of the warnings.



VUJ0000269

1 . Components or assemblies displaying the warning triangle and open book symbol advise consultation of the relevant section of the owners handbook before touching or attempting adjustments of any kind.

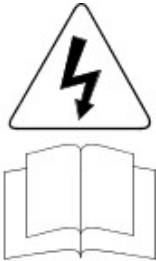

VUJ0000270

2 . Components or assemblies displaying the warning triangle with the electrified arrow and open book symbol give warning of inherent high voltages. Never touch these with the engine running or the ignition switched on. See Electric Shock in this subsection.



VUJ0000271

3 . Jaguar vehicles and replacement parts which contain asbestos are identified by this symbol. See Asbestos in this subsection.



VUJ0000272

4 . Components or assemblies displaying this symbol give warning that the component contains a corrosive substance. See Acids and Alkalis in this subsection.



VUJ0000273

5 . Vehicles displaying the caution circle with a deleted lighted match symbol, caution against the use of naked lights or flames within the immediate vicinity due to the presence of highly flammable or explosive liquids or vapors. See Fire in this subsection.



VUJ0002037

6 . All vehicles fitted with the passenger air bag from the factory have a warning sticker attached to the instrument panel, prohibiting the use of rear facing child seats in the front seating position. Failure to follow this instructions may result in personal injury.

White Spirit

See Solvents.

Safety Precautions



WARNING: Working on the fuel system results in fuel and fuel vapor being present in the atmosphere. Fuel vapor is extremely flammable, hence great care must be taken whilst working on the fuel system. Adhere strictly to the following precautions:

- Do not smoke in the work area.
- Display 'no smoking' signs around the area.
- Disconnect the battery before working on the fuel system.
- Do not connect/disconnect electrical circuits, use electrical equipment or other tools or engage in working practices which in any way may result in the production of sparks.
- Ensure that a CO2 fire extinguisher is close at hand.
- Ensure that dry sand is available to soak up any fuel spillage.
- Empty fuel using suitable fire proof equipment into an authorized explosion proof container.
- Do not empty fuel while working in a workshop or a pit.
- Ensure that working area is well ventilated.
- Ensure that any work on the fuel system is only carried out by experienced and well qualified maintenance personnel.
- Ensure that fume extraction equipment is used where appropriate.



WARNING: Fume extraction equipment must be in operation when solvents are used e.g. Trichloroethane, white spirit, sbp3, methylene chloride, perchlorethylene. Do not smoke in the vicinity of volatile degreasing agents.

Whenever possible, use a ramp or pit whilst working beneath a vehicle, in preference to jacking. Position chocks at the wheels as well as applying the parking brake. Never rely on a jack alone to support a vehicle. Use axle stands, or blocks carefully placed at the jacking points, to provide a rigid location. Check that any lifting equipment used has adequate capacity and is fully serviceable. Ensure that a suitable form of fire extinguisher is conveniently located. When using electrical tools and equipment, inspect the power lead for damage and check that it is properly earthed. Disconnect the earth (grounded) terminal of the vehicle battery. Do not disconnect any pipes of the air conditioning refrigeration system unless you are trained and instructed to do so. A refrigerant is used which can cause blindness if allowed to come into contact with the eyes. Ensure that adequate ventilation is provided when volatile degreasing agents are being used.

Adhere strictly to handling and safety instructions given on containers and labels. Keep oils and solvents away from naked flames and other sources of ignition. Do not apply heat in an attempt to free seized nuts or fittings; as well as causing damage to protective coatings, there is a risk of damage from stray heat to electronic equipment and brake lines. Do not leave tools, equipment, spilt oil etc. around the work area. Wear protective overalls and use barrier cream when necessary.

Environmental Protection

In some countries it is illegal to pour used oil onto the ground, down sewers or drains, or into water courses. The burning of used engine oil in small space heaters or boilers is not recommended unless emission control equipment is fitted. Dispose of used oil through authorized waste disposal contractors, to licensed waste disposal sites or to the waste oil reclamation trade. If in doubt, contact the Local Authority for advice on disposal facilities.

Workshop Manual Organization

This manual covers descriptive, diagnostic (including OBD), and repair aspects to service the vehicle effectively.

The manual is arranged in sections, each section dealing with a specific part of a vehicle system. For example, Section 412-03 covers air conditioning, which is part of the climate control system.

The first digit of the section number indicates the group. There are five groups:

- General Information.
- Chassis.
- Powertrain.
- Electrical.
- Body and Paint.

The second and third digits of the section number indicate the vehicle system.

The last two digits of the section number indicate the part of the system covered by the section.

Important Safety Instructions

Safety Notice

Appropriate service methods and correct repair procedures are essential for the safe, reliable operation of all motor vehicles, as well as the safety of the person doing the work. This manual provides general directions for accomplishing service and repair work with tested effective techniques. Following them will help assure reliability.

There are numerous variations in procedures, techniques, tools, and parts for servicing vehicles, as well as in the skill of the person doing the work. This manual cannot possibly anticipate all such variations and provide advice or cautions as to each. Accordingly, anyone who departs from the instructions provided in the manual must first establish that neither personal safety or vehicle integrity is compromised from choices of methods, tools or parts.

Road/Roller Testing

Road or roller testing may be carried out for various reasons and a procedure detailing pre - test checks, through engine starting and stopping, pre - driving checks, on - test checks to final checks on completion of the test is given overleaf.

Unless complete vehicle performance is being checked, the full road test procedure need not be carried out. Instead, those items particularly relevant to the system/s being checked can be extracted.

Pre - Test Checks



WARNING: If the brake system hydraulic fluid level is low, pedal travel is excessive or a hydraulic leak is found, do not attempt to road test the vehicle until the reason for the low fluid level, excessive pedal travel or hydraulic leak is found and rectified.

It is suggested that pre - test checks, and functional tests of those systems/circuits which affect the safe and legal operations of the vehicle, such as brakes, lights and steering, should always be carried out before the road or roller test.

- Engine oil level
- Engine coolant level
- Tires, for correct pressure, compatible types and tread patterns, and wear within limits.
- There is sufficient fuel in the tank to complete the test.
- All around the engine, transmission and under the vehicle for oil, coolant, hydraulic and fuel leaks. Make a note of any apparent leaks and wipe off the surrounding areas to make it easier to identify the extent of the leak on completion of the test.

Starting the Engine

NOTE:

On initial drive away from cold and within the first 1.5 km (1 mile), do not depress accelerator pedal beyond half travel until the vehicle has attained a minimum speed of 25 km/h (15 miles/h). Never operate at high engine speed or with the accelerator pedal at full travel whilst the engine is cold.

With the ignition switched off, check:

- The handbrake is applied.
- The gear lever is in neutral.
- All instrument gauges (except fuel gauge) read zero.

With the ignition switched on, check:

- Ignition controlled warning lights come on.
- Engine temperature gauge registers a reading compatible with the engine temperature.
- Fuel gauge registers a reading appropriate to the fuel level in the tank.
- The operation of the handbrake warning light and fluid level warning indicator light.

On Road or Roller Test Check:



CAUTION: If road testing, check the brake operation while still travelling at low speed before continuing with the test. If the brakes pull to one side, or appear to be otherwise faulty, do not continue with the road test until the fault has been found and rectified.

- Clutch pedal operation is not stiff or heavy.
- Initial gear engagement is smooth and there is no evidence of clutch drag.
- Handbrake control operates smoothly and the handbrake releases quickly and completely.
- Clutch takes up the drive smoothly, without slip or judder.
- The engine power output is satisfactory, full power is achieved, acceleration is smooth and pedal operation not stiff or heavy, and engine speed returns to idle correctly.
- There is no excessive or abnormally colored smoke from the engine under normal driving, heavy load or overrun conditions.
- Steering operation, including power steering where fitted, is smooth, accurate, not excessively heavy or with excessive free play or vibration. Does not pull to one side and self centres smoothly after cornering.
- Speedometer, oil pressure warning lamp, coolant temperature gauge and tachometer (where fitted) register the correct readings or operate correctly.
- Switches and controls operate smoothly and positively, warning or indicator lights operate correctly and the direction indicator control self cancels when the steering is returned to the straight ahead position.
- Heating and ventilation systems work correctly and effectively.

- Brake operation and efficiency.

Brake Testing



WARNING: When brake testing, avoid breathing the smoke or fumes from hot brakes, this may contain asbestos dust which is hazardous to health, see Health and Safety Precautions.

Avoid brake testing on busy roads where it can cause inconvenience or danger to other road users.



CAUTION: Brake testing which includes heavy brake applications should not be carried out with new brake pads/discs or linings/drums until the components have bedded - in. New brake friction components will not reach full efficiency until the bedding - in process is complete.

Test the brakes at several speeds within the normal operating range using both light and heavy pedal pressure. Note any tendency to snatch, pull or drag, and any undue delay in application or release.

Allow the vehicle to coast and note any tendency to pull to one side, or evidence that the brakes are binding.

After stopping the vehicle (not immediately after a period of heavy braking), carefully check the brake temperature. A disc which feels hot, or appreciably hotter than the others, indicates that the brake is binding.

After completion of the test, check for:

- Oil, coolant, hydraulic, air and fuel leaks.
- Abnormal temperature of any moving components or assemblies, e.g. wheel hubs, transmission, axle etc., which might indicate overtightness or lack of lubrication.

Solvents, Sealants and Adhesives



WARNING: Always handle all solvents, sealers and adhesives with extreme care. Some contain chemicals or give off fumes which can be dangerous to health. Always follow the manufacturers instructions. If in doubt about any substance, particularly a solvent, **DO NOT** use it.



CAUTION: If in doubt about the suitability of any proprietary solvent or sealer for a particular application, contact the manufacturer of the product for information regarding storage, handling and application.

The Solvents, Sealers and Adhesives subsection refers to some commonly used chemicals and materials, hazards associated with their use, and safety measures to be taken.

Adhesives and Sealers

Highly flammable, flammable, combustible – observe No Smoking policy.

Generally should be stored in 'No Smoking' areas. Cleanliness and tidiness in use should be observed e.g. disposable paper covering benches; should be dispensed from applicators where possible; containers, including secondary containers, should be labelled appropriately.

Solvent - based Adhesives/Sealers - See Solvents

Follow manufacturer's instructions.

Water - based Adhesives/Sealers

Those based on polymer emulsions and rubber latexes may contain small amounts of volatile toxic and harmful chemicals. Skin and eye contact should be avoided and adequate ventilation provided during use.

Hot Melt Adhesives

In the solid state, they are safe. In the molten state they may cause burns and health hazards may arise from the inhalation of toxic fumes.

Use appropriate protective clothing and a thermostatically controlled heater with a thermal cut - out and adequate extraction.

Resin - based Adhesives/Sealers e.g. Epoxide and Formaldehyde Resin - based

Mixing should be carried out in well ventilated areas, as harmful or toxic volatile chemicals may be released.

Skin contact with uncured resins and hardeners can result in irritation, dermatitis, and absorption of toxic or harmful chemicals through the skin. Splashes can damage the eyes.

Provide adequate ventilation and avoid skin and eye contact.

Anaerobic, Cyanoacrylate (Super - glues) and other Acrylic Adhesives

Many are irritant, sensitizing or harmful to the skin and/or respiratory tract. Some are eye irritants.

Skin and eye contact should be avoided and the manufacturer's instructions followed.

Cyanoacrylate adhesives (super-glues) **MUST NOT** contact the skin or eyes. If skin or eye tissue is bonded, cover with a clean moist pad and seek immediate medical attention. Do not attempt to pull tissue apart. Use in well ventilated areas as vapors can cause irritation to the nose and eyes.

For two - pack systems see Resin - based and Isocyanate Adhesives/Sealers.

Isocyanate (Polyurethane) Adhesives/Sealers

See also Resin - based Adhesives

Individuals suffering from asthma or respiratory allergies should not work with or near these materials as sensitivity reactions can occur.

Over exposure is irritating to the eyes and respiratory system. Excessive concentrations may produce effects on the nervous system including drowsiness. In extreme cases, loss of consciousness may result. Long term exposure to vapor concentrations may result in adverse health effects.

Prolonged contact with the skin may lead to skin irritation and, in some cases, dermatitis.

Splashes entering the eye will cause discomfort and possible damage.

Any spraying should preferably be carried out in exhaust ventilated booths removing vapors and spray droplets from the breathing zone.

Wear appropriate gloves, eye and respiratory protection.

Standard Workshop Practices

Protecting the Vehicle

Always install covers to protect the fenders before commencing work in the engine compartment. Always install the interior protection kit, wear clean overalls and wash hands or wear gloves before working inside the vehicle. Avoid spilling hydraulic fluid, antifreeze or battery acid on the paintwork. In the event of spillage, wash off with water immediately. Use polythene sheets in the luggage compartment to protect carpets. Always use the recommended service tool, or a satisfactory equivalent, where specified. Protect temporarily exposed screw threads by replacing nuts or installing caps.

Vehicle in Workshop

When working on a vehicle in the workshop always make sure that:

- The parking brake is applied or the wheels are securely chocked to prevent the vehicle moving forwards or backwards
- If the engine is to be run, there is adequate ventilation, or an extraction hose to remove exhaust fumes is installed
- There is adequate room to jack up the vehicle and remove the wheels, if necessary
- Fender covers are always installed if any work is to be carried out in the engine compartment
- The battery is disconnected if working on the engine, underneath the vehicle, or if the vehicle is jacked up



CAUTION: When electric arc welding on a vehicle, always disconnect the generator wiring to prevent the possibility of a surge of current causing damage to the internal components of the generator.

- If using welding equipment on the vehicle, ensure a suitable fire extinguisher is readily available.

Identification Codes

Vehicle Identification Number (VIN)

The official VIN is stamped on the right hand side of the boot compartment floor. An additional quick reference and anti forgery identification number is stamped onto a metal plate and fastened to the instrument panel. It is positioned close to the left-hand side of the vehicle and is visible from the outside.

The vehicle identification number is also located on a vehicle certification label or vin plate which is mounted on the bottom of the 'B' Post.

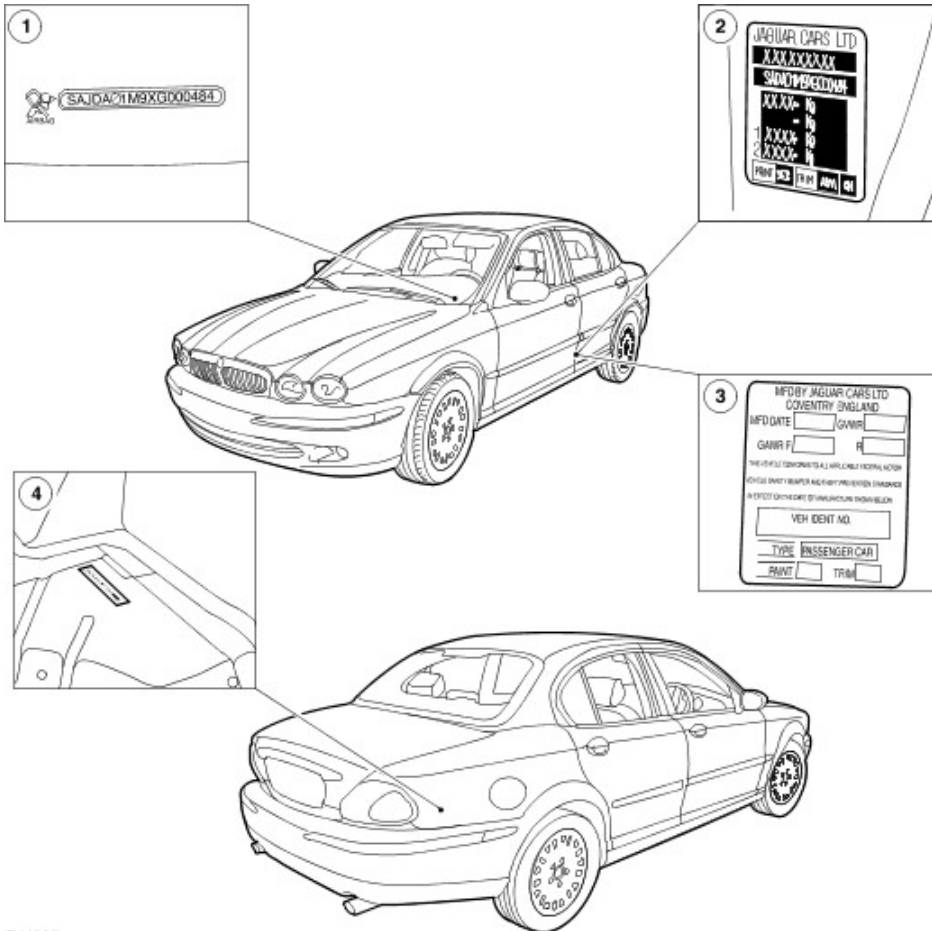

E44825

Item	Part Number	Description
1	—	Quick reference plate
2	—	Certification label (Europe and Rest of the World)
3	—	Certification label (USA)
4	—	Official VIN plate

Vehicle Identification Number (Example)

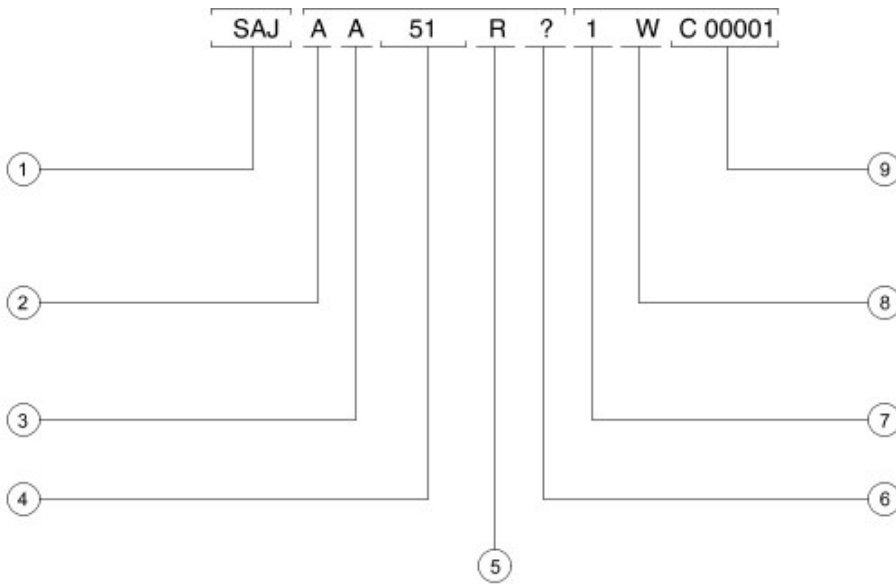

VUJ0003165

Item	Part Number	Description
1	—	World manufacturer identifier
2	—	Market, air bag specification
3	—	Transmission and steering code
4	—	Body code
5	—	Engine emission system
6	—	Check digit
7	—	Model year
8	—	Assembly plant, model line
9	—	Production sequence number

World Manufacturer Identifier

VIN Positions 1, 2 and 3

Codes	Manufacturer	Make	Type
SAJ	Jaguar Cars Limited, England	Jaguar	Passenger Car

Market, Air Bag Specification

VIN position 4

VIN code	Description
A	Rest of World with twin air bags, side air bags and curtain air bags
K	Japan with twin air bags, side air bags and curtain air bags
W	USA with twin air bags, side air bags and curtain air bags
X	Canada with twin air bags, side air bags and curtain air bags
Y	Mexico with twin air bags, side air bags and curtain air bags

Transmission, Steering Code

VIN Position 5

VIN Code	Description
A	AWD Automatic LHS
B	AWD Manual LHS
C	AWD Automatic RHS
D	AWD Manual RHS
E	FWD Automatic LHS

F	FWD Manual LHS
G	FWD Automatic RHS
H	FWD Manual RHS

Body Code

VIN Position 6 and 7

VIN Code	Description
51	4-Door, 5 seat saloon high series
52	4-Door, 5 seat saloon entry series
53	4-Door, 5 seat saloon sport series
54	5-Door, 5 seat wagon high series
55	5-Door, 5 seat wagon entry series
56	5-Door, 5 seat wagon sport series

Engine Emission System

VIN Position 8

NOTE:

*1 EU. Includes the following markets; Austria, Belgium, Cyprus, Czech Rep, Denmark, Estonia, Finland, France, Germany, Greece, Netherlands, Hungary, Italy, Latvia, Lithuania, Luxembourg, Malta, Poland, Portugal, Rep. of Ireland, Slovenia, Slovakia, Spain (including Canary Islands), Sweden, Bulgaria, Romania and UK.

NOTE:

*2 East Europe. Includes the following markets; Croatia and Serbia.

NOTE:

*3 Russia. Includes the following markets; Belarus, Kazakhstan, Ukraine and Uzbekistan.

NOTE:

*4 Middle East. Includes the following markets; Abu Dhabi, Bahrain, Dubai, Jordan, Kuwait, Lebanon, Oman, Qatar, Saudi Arabia.

VIN Code	Engine	Market
F	2.5L	Argentina, Dominican Rep, Guatemala, *4 Middle East, Panama, Uruguay, Philippines and Taiwan
E	3.0L	
N	2.0L	
M	2.5L	*2 East Europe, Morocco, *3 Russia and Chile
L	3.0L	
S	2.0L	
M	2.5L	*1 EU, Israel, Norway, Switzerland, and Turkey
L	3.0L	
N/A	2.0L	
K	2.5L	Brazil
J	3.0L	
N/A	2.0L	
H	2.5L	Egypt, Syria and South Korea
G	3.0L	
P	2.0L	
M	2.5L	Japan
L	3.0L	
S	2.0L	
N/A	2.5L	USA
A	3.0L	
N/A	2.0L	
N/A	2.5L	Canada
A	3.0L	

N/A	2.0L	
N/A	2.5L	Mexico
L	3.0L	
N/A	2.0L	
F	2.5L	Indonesia, Malaysia, Singapore, Sri Lanka and Thailand
E	3.0L	
N	2.0L	
M	2.5L	Australia, Hong Kong and New Zealand
L	3.0L	
S	2.0L	
H	2.5L	South Africa (includes Trinidad and Tobago)
G	3.0L	
P	2.0L	
M	2.5L	Cyprus, Malta and UK (and Eire)
L	3.0L	
N/A	2.0L	
1	2.0L Diesel	Argentina, *2 East Europe, *1 EU, Morocco, Norway, Switzerland, Turkey, Uruguay and *3 Russia
1	2.2L Diesel	Argentina, *2 East Europe, *1 EU (except Belgium), Morocco, Norway, Switzerland, Turkey, Uruguay and *3 Russia
2	2.2L Diesel	Belgium (110 Kw engine only)
1	2.0L Diesel	Cyprus, Malaysia, Malta, UK (and Eire), South Africa (includes Trinidad and Tobago)
1	2.2L Diesel	Cyprus, Malaysia, Malta, UK (and Eire), South Africa (includes Tobago)
3	2.2L Diesel + cDPF	*1 EU, Norway, Switzerland, and Turkey

Check Digit

VIN Position 9

VIN Code	Description
0 - 9 or X	Calculated in accordance with American standard CFR part 565

Model Year

VIN Position 10

VIN Code	Description
6	2006 Model Year
7	2007 Model Year

Assembly Plant and Model Line

VIN Position 11

VIN Code	Description
W	Halewood 3.0L
X	Halewood 2.5L
Y	Halewood 2.0L
6	Halewood 2.0L Diesel
B	Halewood 2.2L Diesel

Production Sequence Number

VIN Position 12 through 17

Sequence Number
C00001 - C99999

D00001 - D99999
E00001 - E99999
J00001 - J99999
K00001 - K99999
S00001 - S99999
T00001 - T99999
V00001 - V99999

Vehicle Certification Label

The vehicle certification label also contains the 17 character vehicle identification number. This number is used for warranty identification of the vehicle.

Vehicle Certification Number (Europe and Rest of the World)

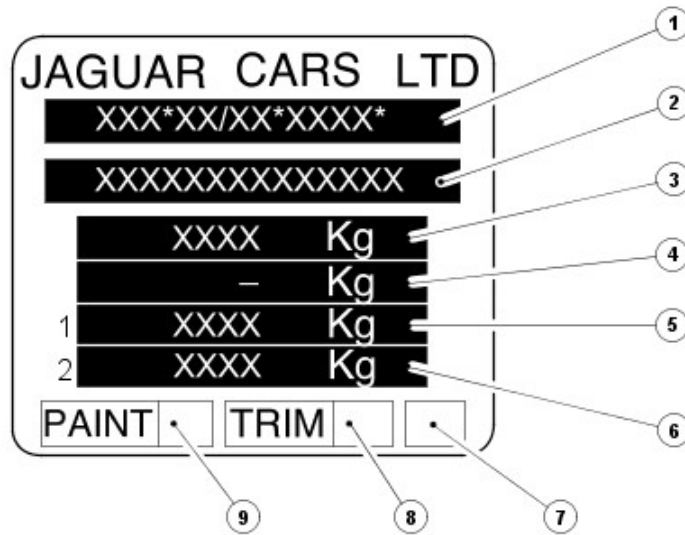

E36533

Item	Part Number	Description
1	—	WVTA number printed here when applicable
2	—	Vehicle identification number
3	—	Gross vehicle weight
4	—	Gross train weight
5	—	Maximum permitted front axle loading
6	—	Maximum permitted rear axle loading
7	—	Date of manufacture
8	—	Interior trim code
9	—	Paint code

Vehicle Identification Label (USA)

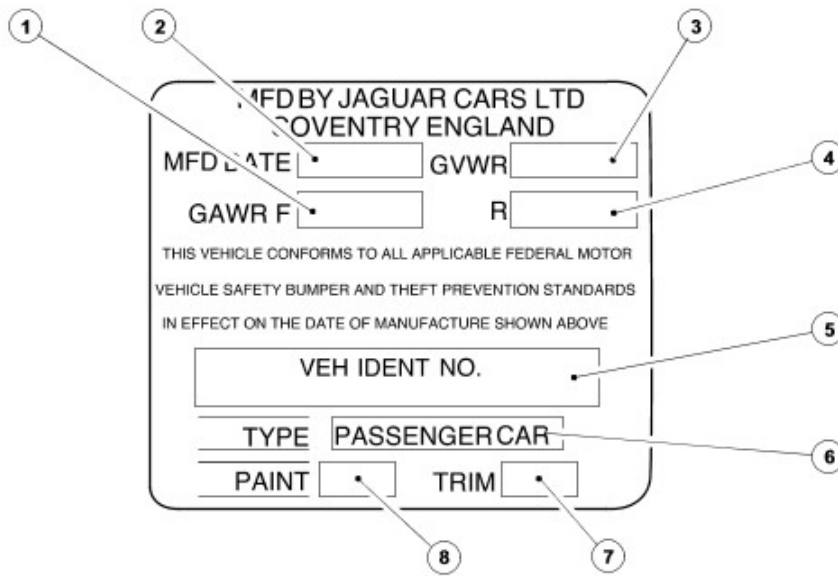

VUJ0003210

Item	Part Number	Description
1	—	Maximum permitted front axle loading
2	—	Date of manufacture
3	—	Gross vehicle weight
4	—	Maximum permitted rear axle loading
5	—	Vehicle identification number
6	—	Type
7	—	Interior trim code
8	—	Paint code

Vehicle Identification Label (Saudi Arabia and Gulf States)

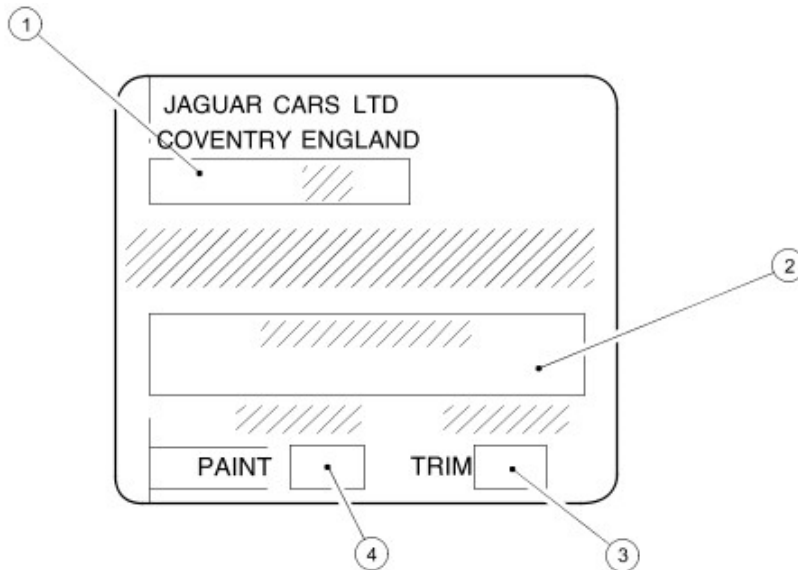

VUJ0001852

Item	Part Number	Description
1	—	Date of manufacture
2	—	Vehicle identification number
3	—	Interior trim code
4	—	Paint code

Vehicle Identification Label (Canada)

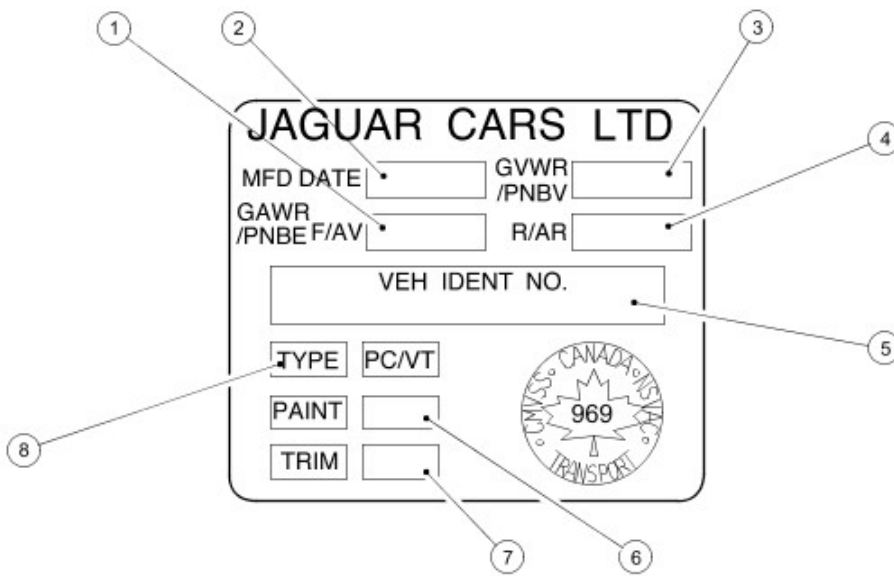

VUJ0001853

Item	Part Number	Description
1	—	Maximum permitted front axle loading
2	—	Date of manufacture
3	—	Gross vehicle weight
4	—	Maximum permitted rear axle loading
5	—	Vehicle identification number
6	—	Paint code
7	—	Interior trim code
8	—	Type

Automatic Transmission Number

The serial number of the automatic transmission unit is displayed on a metal label or bar code (where equipped) attached to the transmission casing.

Manual Transmission Number

The serial number of the manual transmission unit is displayed on a metal label or bar code (where equipped) attached to the transmission casing.

Engine Number (V6)

The engine number is stamped on an engine web on the right hand side of the cylinder block behind the engine mounting..

Engine Number (Diesel)

The engine number is contained on a bar code label on the front cover and is also stamped in the cylinder block casting.

Identification Codes

Vehicle Identification Number (VIN)

The official VIN is located on the right hand side of the boot compartment floor and is stamped in a dot matrix format. An additional quick reference and anti forgery identification number is stamped onto a metal plate and fastened to the instrument panel. It is positioned close to the left-hand side of the vehicle and is visible from the outside.

The vehicle identification number is also located on a vehicle certification label which is mounted on the bottom of the 'B' Post.

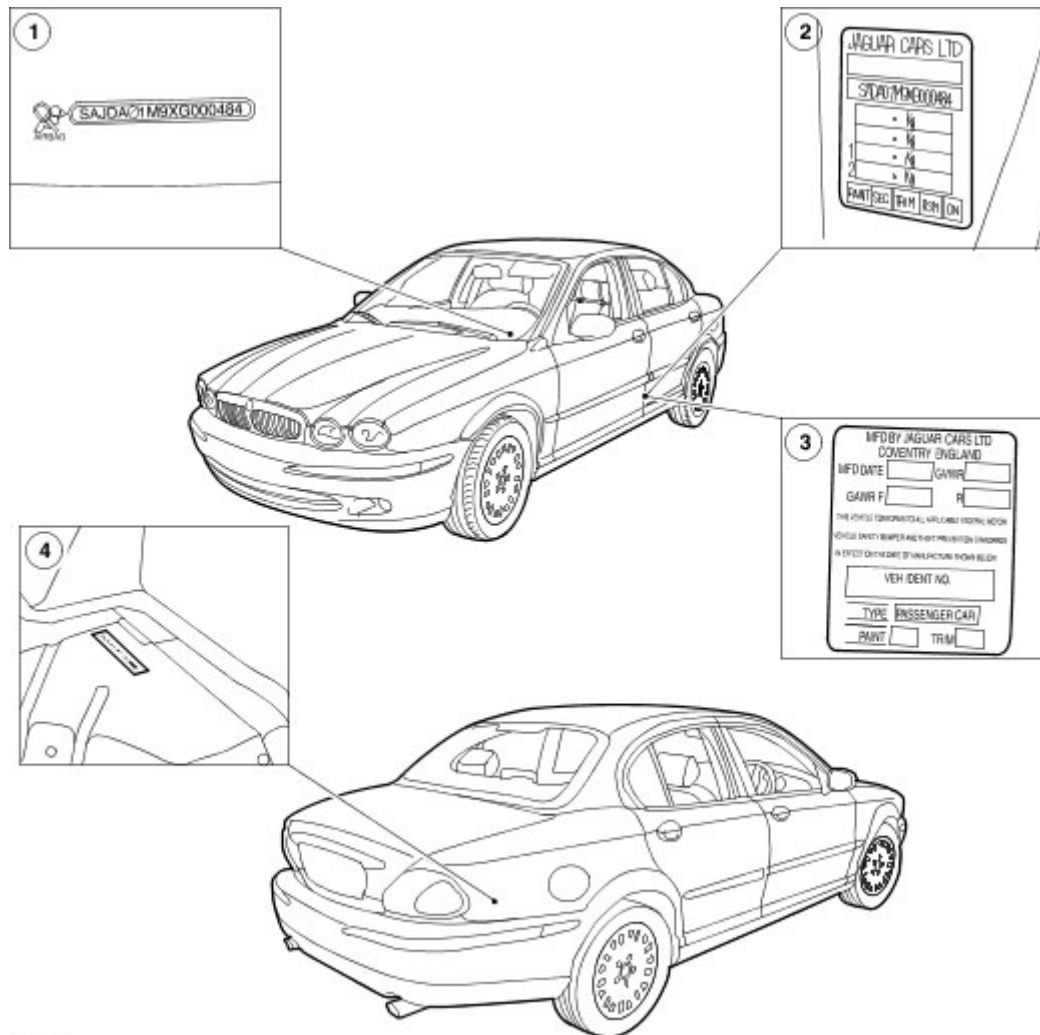

E30810

Item	Part Number	Description
1	—	Quick reference plate
2	—	Certification label (Europe and Rest of the World)
3	—	Certification label (America)
4	—	Official VIN plate

Vehicle Identification Number (Example)

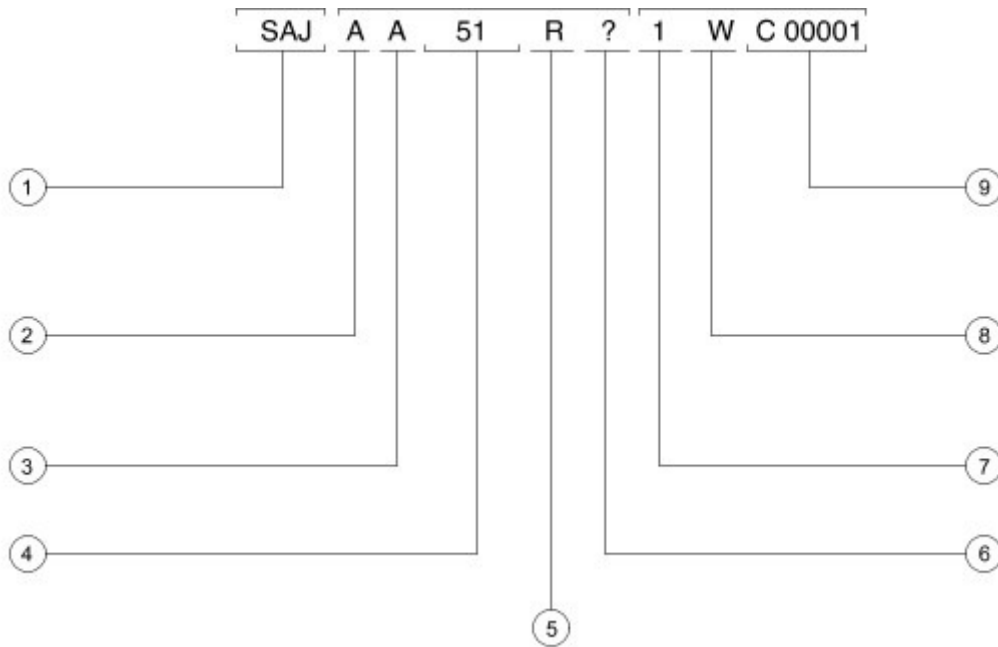

VUJ0003165

Item	Part Number	Description
1	—	World manufacturer identifier
2	—	Market, restraint system
3	—	Transmission and steering code
4	—	Body code
5	—	Engine emission control system
6	—	Check digit
7	—	Model year
8	—	Assembly plant, model line
9	—	Production sequence number

World Manufacturer Identifier

VIN Positions 1

Codes	Manufacturer	Make	Type
SAJ	Jaguar Cars Limited, England	Jaguar or Daimler	Passenger Car

Market, Restraint system

VIN position 2

VIN code	Description
A	Rest of the world with twin air bags, side air bags and curtain airbags

Transmission, Steering Code

VIN Position 3

VIN Code	Description
A	Automatic LHS
B	Manual LHS

C	Automatic RHS
D	Manual RHS
E	FWD Automatic LHS
F	FWD Manual LHS
G	FWD Automatic RHS
H	FWD Manual RHS

Body Code

VIN Position 4

VIN Code	Description
51	4-Door, 5 seat saloon (High)
52	4-Door, 5 seat saloon (Entry)
53	4-Door, 5 seat saloon (Sports)

Engine Emission Control System

VIN Position 5

VIN Code	Description
L	Emission control system 3.0L
M	Emission control system 2.5L
S	Emission control system 2.0L

Check Digit

VIN Position 6

VIN Code	Description
0 - 9 or X	Calculated in accordance with american standard CFR part 565

Model Year

VIN Position 7

VIN Code	Description
1	2001 Model Year
2	2002 Model Year
3	2003 Model Year

Assembly Plant and Model Line

VIN Position 8

VIN Code	Description
W	Halewood 3.0L
X	Halewood 2.5L
Y	Halewood 2.0L

Production Sequence Number

VIN Position 9

Sequence Number
C00001 - C99999
D00001 - D99999
E00001 - E99999
J00001 - J99999
K00001 - K99999
S00001 - S99999
T00001 - T99999
V00001 - V99999

Vehicle Certification Label

The vehicle certification label also contains the 17 character vehicle identification number. This number is used for warranty identification of the vehicle.

Vehicle Certification Number (Europe and Rest of the World)

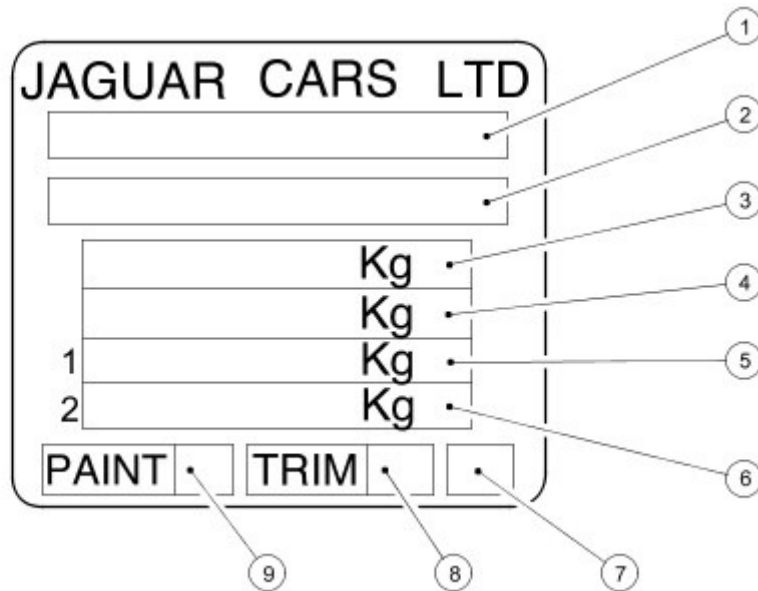

VUJ0001850

Item	Part Number	Description
1	—	WVTA number printed here when applicable
2	—	Vehicle identification number
3	—	Gross vehicle weight
4	—	Gross train weight
5	—	Maximum permitted front axle loading
6	—	Maximum permitted rear axle loading
7	—	Date of manufacture
8	—	Interior trim code
9	—	Paint code

Vehicle Identification Label (North America)

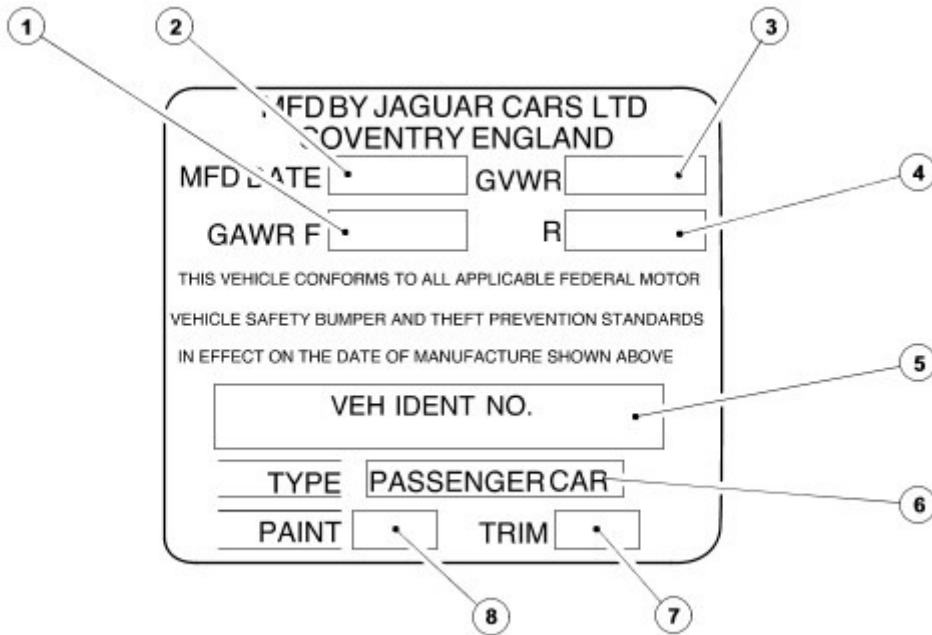

VUJ0003210

Item	Part Number	Description
1	—	Maximum permitted front axle loading
2	—	Date of manufacture
3	—	Gross vehicle weight
4	—	Maximum permitted rear axle loading
5	—	Vehicle identification number
6	—	Type
7	—	Interior trim code
8	—	Paint code

Vehicle Identification Label (Saudi Arabia and Gulf States)

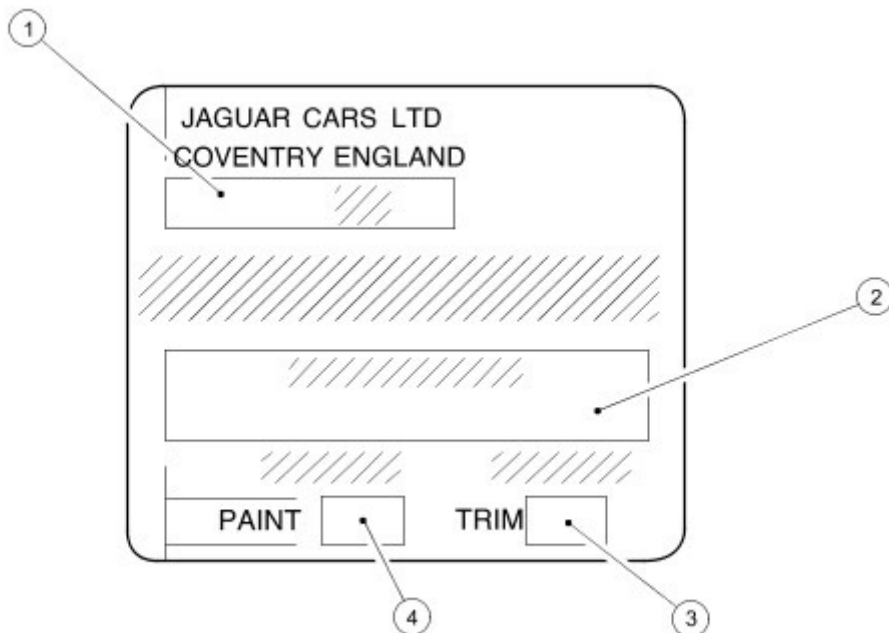

VUJ0001852

Item	Part Number	Description
1	—	Date of manufacturer

2	—	Vehicle identification number
3	—	Interior trim code
4	—	Paint code

Vehicle Identification Label (Canada)

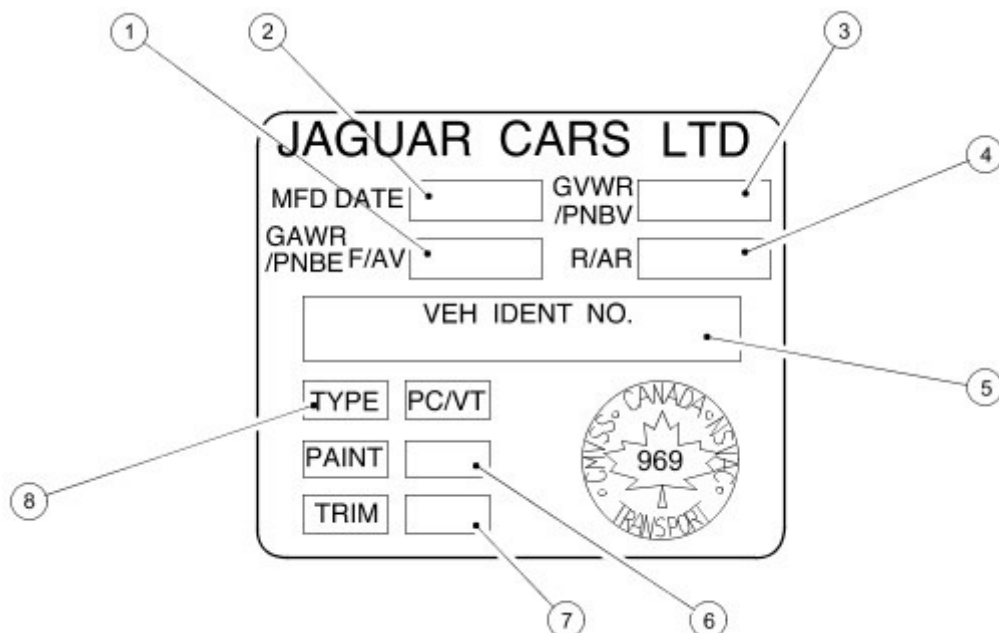

VUJ0001853

Item	Part Number	Description
1	—	Maximum permitted front axle loading
2	—	Date of manufacturer
3	—	Gross vehicle weight
4	—	Maximum permitted rear axle loading
5	—	Vehicle identification number
6	—	Paint code
7	—	Interior trim code
8	—	Type

Automatic Transmission Number

The serial number of the transmission unit is displayed on a metal label or bar code (where equipped) attached to the transmission casing.

Engine Number (2.0L, 2.5L and 3.0L)

The engine number is contained on a bar code label on the front cover and is also stamped in the cylinder block casting.

Jacking

Safety Precautions



CAUTION: The jack provided with the vehicle is intended to be used in an emergency for changing a deflated tire. To avoid damage to the vehicle, never use the jack to raise the vehicle for any other purpose. Refer to the Driver Handbook when using the jack supplied with the vehicle. Failure to follow these instructions can result in personal injury.

The following safety precautions must be observed when raising the vehicle to carry out service operations:

- Never rely on a jack alone to support a vehicle; use suitable vehicle stands to provide rigid support.
- When working beneath a vehicle, whenever possible, use a vehicle hoist instead of a jack and vehicle stands.
- Make sure that the vehicle is standing on firm, level ground before using a jack.
- Do not rely on the parking brake alone; chock the wheels and put the automatic transmission into PARK if possible.
- Check that any lifting equipment used has adequate capacity for the load being lifted and is in correct working order.

Lifting

Lifting Points—Twin-Post Hoist and Floor Jack



CAUTION: Do not allow the hoist adapters to contact the steering linkage, suspension arms, stabilizer bar, rear subframe stabilizer brackets or to compress the lower suspension arm stabilizer bar insulator. Damage to the suspension, exhaust and steering linkage components may occur if care is not exercised when positioning the hoist adapters of two-post hoists prior to lifting the vehicle.



CAUTION: Never use the differential housing as a lift point. Damage to the differential housing and cover may occur.



CAUTION: When using a floor jack, a cushioned pad must be utilized to avoid body damage.

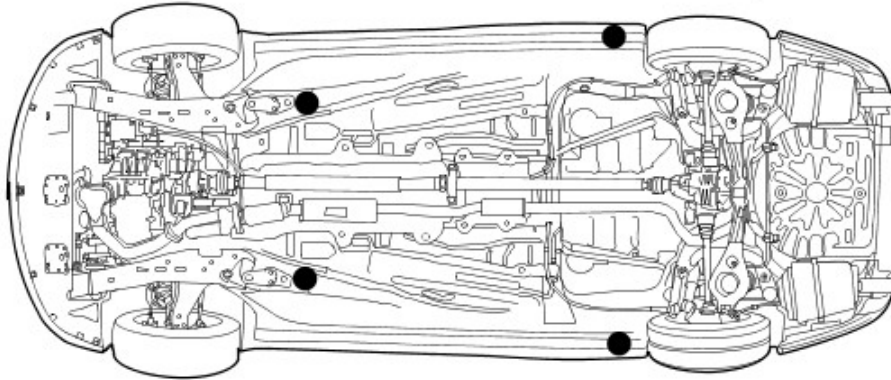
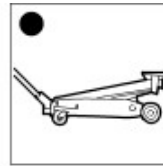

VJJ0003970

Vehicle Support Points



CAUTION: When using vehicle support stands a cushioned pad must be utilized to avoid body damage.

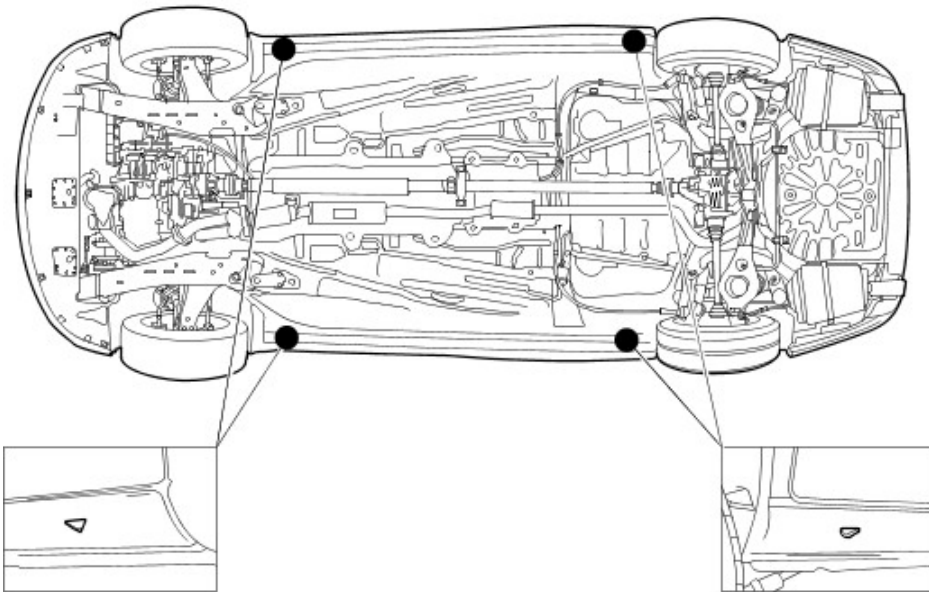
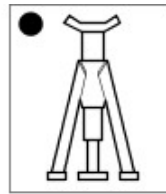

VUJ0003969

Vehicle Recovery

NOTE:

Prior to vehicle recovery, make sure that the vehicle keys are available and the security system is disarmed.

Vehicle recovery methods are:

- By flat-bed transporter.
- By front suspended tow.

Transporter or Trailer Recovery

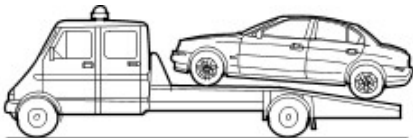

VUJ0001116

When the vehicle is being recovered by transporter or trailer:

- The parking brake must be applied and the wheels chocked.
- The gear selector lever must be in NEUTRAL. Do not select PARK on automatic transmission vehicles, as the parking lock mechanism may be damaged by the forward and backward rocking motion of the vehicle.
- The vehicle must be securely tied down to the transporter or trailer.

Front Suspended Tow

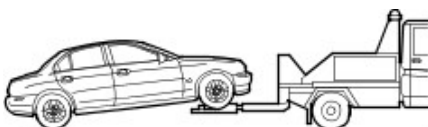

VUJ0003968

When the vehicle is being recovered by front suspended tow:



CAUTION: The driveshaft must be disconnected.

- The ignition key must be removed from the ignition switch to lock the steering.
- The front wheels must be correctly positioned in the lifting cradle and securely tied down.

Emergency Towing-Vehicles fitted with manual transmission:



WARNING: If the engine is not running, the steering will become heavy and the force necessary to effectively apply the brakes will be greatly increased.



CAUTION: A vehicle with a defective transmission must be towed by front suspended tow.

When the vehicle is being towed with all four wheels on the ground:

- Local regulations for the towing of vehicles must be followed. In some countries the registration number of the towing vehicle and an 'On Tow' sign or warning triangle must be displayed at the rear of the towed vehicle.
- The gear selector lever must be in NEUTRAL.
- The ignition switch must be in the RUN position to release the steering lock and make the direction indicators, horn and stop lamps operate.
- A distance of 48 kms (30 miles) must not be exceeded.
- A speed of 48 km/h (30 mph) must not be exceeded.
- The tow rope must be attached to the front towing eye.

Emergency Towing-Vehicles fitted with automatic transmission:



WARNING: If the engine is not running, the steering will become heavy and the force necessary to effectively apply the brakes will be greatly increased.



CAUTION: A vehicle with a defective transmission must be towed by front suspended tow.

When the vehicle is being towed with all four wheels on the ground:

- Local regulations for the towing of vehicles must be followed. In some countries the registration number of the towing vehicle and an 'On Tow' sign or warning triangle must be displayed at the rear of the towed vehicle.
- The gear selector lever must be in NEUTRAL.
- The ignition switch must be in the RUN position to release the steering lock and make the direction indicators, horn and stop lamps operate.
- A distance of 0.8 kms (0.5 miles) must not be exceeded.
- A speed of 48 km/h (30 mph) must not be exceeded.
- The tow rope must be attached to the front towing eye.

Exhaust System Neutralizing

1. Loosen the muffler inlet pipe and resonator pipe to exhaust manifold fasteners at the flanges and the muffler inlet connection.
2. Place a stand to support the muffler parallel to the vehicle frame with the muffler pipe bracket free of stress.
3. Tighten the muffler connection.
4. Position the exhaust pipes to the manifolds and tighten. Make sure that the catalytic converters and heat shields do not contact the frame rails.
5. With the complete exhaust system tight (and cooled) the rear hanger insulator should be angled forward, to allow the system to expand rearward when heated during normal running.

Noise, Vibration and Harshness (NVH)

Noise, vibration and harshness (NVH) is becoming more important as vehicles become more sophisticated and passenger comfort levels increase. This section is designed to aid in the diagnosis, testing and repair of NVH concerns.

- noise is defined as sounds not associated with the operation of passenger compartment equipment that interface with customer satisfaction.
- vibration is defined as impulses felt by the customer that are not caused by road surface changes.
- harshness is a ride quality issue where the customer feels that the vehicle response to the road surface is sharply transmitted to the customer.

Diagnostic Theory

Diagnosis is more than just following a series of interrelated steps in order to find the solution to the specific condition. It is a way of looking at systems that are not functioning the way they should and finding out why. Also it is knowing how the system should work and whether it is working correctly.

There are basic rules for diagnosis. If these rules are followed, the cause of the condition is usually found the first time through the system.

Know the System

- know how the parts go together.
- know how the system operates as well as its limits and what happens when the system goes wrong.
- sometimes this means checking the system against one that is known to be working correctly.

Know the History of the System

A clue in any one of these areas may save time:

- how old or new is the system?
- what kind of treatment has it had?
- has it been repaired in the past in such a manner that might relate to the present condition?
- what is the repair history?

Know the History of the Condition

- did it start suddenly or appear gradually?
- was it related to some other occurrence such as a collision or previous part renewal?
- know how the condition made itself known; it may be an important clue to the cause.

Know the Probability of Certain Conditions Developing

- Look for the simple rather than the complex.
- For example: Electrical conditions usually occur at connections rather than components. An engine no-start is more likely to be caused by a loose wire or small adjustment rather than a sheared-off camshaft.
 - Electrical conditions usually occur at connections rather than components.
 - An engine no-start is more likely to be caused by a loose wire or small adjustment rather than a sheared-off camshaft.
- Know the difference between impossible and improbable. Certain failures in a system can be improbable but still happen.
- New parts are just that, new. It does not mean they are always good functioning parts.

Do Not Cure the Symptom and Leave the Cause

Lowering the pressure in a front tire may correct the condition of a vehicle leaning to one side, but it does not correct the original condition.

Be Positive the Cause is Found

- double check the findings.
- what caused a worn component?
- a loose transmission or engine mount could indicate that other mounts are also loose.

Diagnostic Charts

Charts are a simple way of expressing the relationship between basic logic and a physical system of components. They help discover the cause of a condition in the least time. Diagnostic charts combine many areas of diagnosis into one visual display:

- probability of certain things occurring in a system
- speed of checking certain components or functions before others

- simplicity of carrying out certain tests before others
- elimination of checking huge portions of a system by carrying out simple tests
- certainty of narrowing down the search to a small portion before carrying out in-depth testing

The fastest way to find a condition is to work with the tools that are available. This means working with proven diagnostic charts and the correct special equipment for the system.

Noise, Vibration and Harshness (NVH)

Inspection and Verification

- 1 . Verify the customer concern.
- 2 . Visually inspect for obvious signs of mechanical damage.
- 3 . If an obvious cause for an observed or reported concern is found, correct the cause (if possible) before proceeding to the next step.
- 4 . If the concern(s) remains after the inspection, determine the symptom(s) and go to the Symptom Chart.

How To Use This Diagnostic Procedure Section

- Noise, vibration and harshness (NVH) concerns have become more important as vehicles have become more sensitive to these vibrations. This section is designed as an aid to identifying these situations.
- The section provides diagnostic procedures based on symptoms. If the condition occurs at high speed, for instance, the most likely place to start is under High Speed Shake.
- The road test procedure will tell how to sort the conditions into categories and how to tell a vibration from a shake.
- A series of Road Test Quick Checks is provided to make sure that a cause is either pinpointed or eliminated.
- Name the condition, proceed to the appropriate section and locate the correct diagnosis. When the condition is identified, the job is partly done.
- Follow the diagnostic procedure as outlined.
- Quick Checks are described within the step, while more involved tests and adjustments are outlined in General Procedures.
- Always follow each step exactly and make notes to recall important findings later.

Customer Interview

The road test and customer interview (if available) provide information that will help identify the concerns and will provide direction to the correct starting point for diagnosis.

Identify the Condition

NVH usually occurs in a number of areas:

- tires
- engine accessories
- suspension
- driveline
- air leakage (wind noise)
- squeaks and rattles
- Heating ventilation and air conditioning (HVAC)
- electrical (e.g. motor noise)

It is important, therefore, that an NVH concern be isolated into its specific area(s) as soon as possible. The easiest and quickest way to do this is to carry out the Road Test as outlined.

Noise Diagnostic Procedure

Non-Axle Noise

The five most important sources of non-axle noise are exhaust, tires, roof racks, trim and mouldings, and transmission.

Therefore, make sure that none of the following conditions are the cause of the noise before proceeding with a driveline teardown and diagnosis.

- In certain conditions, the pitch of the exhaust may sound very much like gear noise. At other times, it can be mistaken for a wheel bearing rumble.
- Tires, especially snow tires, can have a high pitched tread whine or roar, similar to gear noise. Radial tires, to some degree, have this characteristic. Also, any non-standard tire with an unusual tread construction may emit a roar or whine type noise.
- Trim and mouldings can also cause whistling or a whining noise.
- Clunk may be a metallic noise heard when the automatic transmission is engaged in reverse or drive, or it may occur when the throttle is applied or released. It is caused by backlash somewhere in the driveline.
- Bearing rumble sounds like marbles being tumbled. This condition is usually caused by a damaged wheel bearing.

Noise Conditions

- Gear noise is typically a howling or whining due to gear damage or incorrect bearing preload. It can occur at various speeds and driving conditions, or it can be continuous.
- Chuckle is a particular rattling noise that sounds like a stick against the spokes of a spinning bicycle wheel. It occurs while decelerating from 64 km/h (40 mph) and can usually be heard all the way to a stop. The frequency varies with vehicle speed.
- Knock is very similar to chuckle, though it may be louder and occurs on acceleration or deceleration. The teardown will disclose what has to be corrected.

Check and rule out tires, exhaust and trim items before disassembling the transmission to diagnose and correct gear noise.

The noises described under Road Test usually have specific causes that can be diagnosed by observation as the unit is disassembled. The initial clues are the type of noise heard on the road test and the driving conditions.

Vibration Conditions

NOTE:

New constant velocity (CV) joints should not be installed unless disassembly and inspection revealed unusual wear.

Clicking, popping or grinding noises may be caused by the following:

- cut or damaged drive half shaft joint boots resulting in inadequate or contaminated lube in the outboard or inboard CV joint bearing housings
- loose drive half shaft joint boot clamps
- another component contacting the drive half shaft
- worn, damaged or incorrectly installed wheel bearing, suspension or brake component

Vibration at highway speeds may be caused by the following:

- out-of-balance front or rear wheels
- out-of-round tires
- driveline imbalance
- driveline run-out (alignment)

NOTE:

Drive half shafts are not balanced and do not contribute to rotational vibration disturbances.

Shudder or vibration during acceleration may be caused by the following:

- Excessively worn or damaged outboard or inboard CV joint shaft pilot bearing housing
- Excessively high CV joint operating angles caused by incorrect ride height. Check ride height, verify correct spring rate and check items under Inoperative Conditions

Leakage Conditions

- 1 . Inspect the CV joint boots for evidence of cracks, tears or splits.
- 2 . Inspect the underbody for any indication of grease splatter in the vicinity of the front or rear wheel drive half shaft joints and boots. If any grease is present this indicates damage to the half shaft joint boot or boot clamp.
- 3 . Inspect the inboard CV joint stub shaft pilot bearing housing seal for leakage at the inboard CV joint pilot bearing housing.

Inoperative Conditions

If a CV joint or half shaft pull-out occurs, check the following:

- suspension components for correct location, damage or wear
- bushings for wear
- subframe for damage
- bent or worn components: stabilizer bar link left-hand rear suspension lower arm and bushing right-hand rear suspension lower arm and bushing rear wheel hub and half shaft left-hand front suspension lower arm and bushing right-hand front suspension lower arm and bushing front wheel hub and half shaft

Road Test

A gear-driven unit will produce a certain amount of noise. Some noise is acceptable and may be audible at certain speeds or under various driving conditions as on a newly paved blacktop road. The slight noise is in no way detrimental and must be considered normal.

The road test and customer interview (if available) provide information needed to identify the condition and give direction to the correct starting point for diagnosis.

- 1 . Make notes throughout the diagnosis routine. Make sure to write down even the smallest bit of information, because it may turn out to be the most important.

2 . Do not touch anything until a road test and a thorough visual inspection of the vehicle have been carried out. Leave the tire pressures and vehicle load just where they were when the condition was first observed. Adjusting tire pressures, vehicle load or making other adjustments may reduce the conditions intensity to a point where it cannot be identified clearly. It may also inject something new into the system, preventing correct diagnosis.

3 . Make a visual inspection as part of the preliminary diagnosis routine, writing down anything that does not look right. Note tire pressures, but do not adjust them yet. Note leaking fluids, loose nuts and bolts, or bright spots where components may be rubbing against each other. Check the luggage compartment for unusual loads.

4 . Road test the vehicle and define the condition by reproducing it several times during the road test.

5 . Carry out the Road Test Quick Checks as soon as the condition is reproduced. This will identify the correct diagnostic procedure. Carry out the Road Test Quick Checks more than once to verify they are providing a valid result. Remember, the Road Test Quick Checks may not tell where the concern is, but they will tell where it is not.

Road Test Quick Checks

1 . 24-80 km/h (15-50 mph): With light acceleration, a moaning noise is heard and possibly a vibration is felt in the front floor pan. It is usually worse at a particular engine speed and at a particular throttle setting during acceleration at that speed. It may also produce a moaning sound, depending on what component is causing it. Refer to Tip-In Moan in the Symptom Chart.

2 . Acceleration/Deceleration: With slow acceleration and deceleration, a shake is sometimes noticed in the steering wheel/column, seats, front floor pan, front door trim panel or front end sheet metal. It is a low frequency vibration (around 9-15 cycles per second). It may or may not be increased by applying brakes lightly. Refer to Idle Boom/Shake/Vibration in the Symptom Chart.

3 . High Speed: A vibration is felt in the front floor pan or seats with no visible shake, but with an accompanying sound or rumble, buzz, hum, drone or booming noise. Coast with the clutch pedal depressed or shift control selector lever in neutral and engine idling. If vibration is still evident, it may be related to wheels, tires, front disc brake discs, wheel hubs or front wheel bearings. Refer to High Speed Shake in the Symptom Chart.

4 . Engine rpm Sensitive: A vibration is felt whenever the engine reaches a particular rpm. It will disappear in neutral coasts. The vibration can be duplicated by operating the engine at the problem rpm while the vehicle is stationary. It can be caused by any component, from the accessory drive belt to the clutch or torque converter which turns at engine speed when the vehicle is stopped. Refer to High Speed Shake in the Symptom Chart.

5 . Noise and Vibration While Turning: Clicking, popping, or grinding noises may be due to the following:

- worn, damaged, or incorrectly installed front wheel bearing
- worn, damaged or incorrectly installed half shaft.

Road Conditions

An experienced technician will always establish a route that will be used for all NVH diagnosis road tests. The road selected should be reasonably smooth, level and free of undulations (unless a particular condition needs to be identified). A smooth asphalt road that allows driving over a range of speeds is best. Gravel or bumpy roads are unsuitable because of the additional road noise produced. Once the route is established and consistently used, the road noise variable is eliminated from the test results.

NOTE:

Some concerns may be apparent only on smooth asphalt roads.

If a customer complains of a noise or vibration on a particular road and only on a particular road, the source of the concern may be the road surface. If possible, try to test the vehicle on the same type of road.

Vehicle Preparation

Carry out a thorough visual inspection of the vehicle before carrying out the road test. Note anything which is unusual. Do not repair or adjust any condition until the road test is carried out, unless the vehicle is inoperative or the condition could pose a hazard to the technician.

After verifying the condition has been corrected, make sure all components removed have been installed.

Lift Test

After a road test, it is sometimes useful to do a similar test on a lift.

When carrying out the high-speed shake diagnosis or engine accessory vibration diagnosis on a lift, observe the following precautions:



WARNING: If only one drive wheel is allowed to rotate, speed must be limited to 55 km/h (35 mph) indicated on the speedometer since actual wheel speed will be twice that indicated on the speedometer. Speed exceeding 55 km/h (35 mph) or allowing the drive wheel to hang unsupported could result in tire disintegration, differential failure, constant velocity joint

and driveshaft failure, which could cause serious personal injury and extensive vehicle damage. Failure to follow these instructions may result in personal injury.



CAUTION: The suspension should not be allowed to hang free. When the CV joint is run at a very high angle, extra vibration as well as damage to the seals and joints can occur.

The suspension lower arms should be supported as far outboard as possible. To bring the vehicle to its correct ride height, the full weight of the vehicle should be supported in the rear by floor jacks. For additional information, refer to

[Jacking](#)

1 . Raise and support the vehicle. For additional information, refer to

[Lifting](#)

2 . Explore the speed range of interest using the Road Test Quick Checks as previously described.

3 . Carry out a coast down in neutral. If the vehicle is free of vibration when operating at a steady indicated speed and behaves very differently in drive and coast, a transmission concern is likely.

Note, however, that a test on the lift may produce different vibrations and noises than a road test because of the effect of the lift. It is not unusual to find vibrations on the lift that were not found in the road test. If the condition found on the road can be duplicated on the lift, carrying out experiments on the lift may save a great deal of time.

Symptom Chart

High-speed shake

Possible Source(s):

- Wheel end vibration
- Engine/gearbox/transfer box
- Driveline

Action(s) to take:

- GO to Pinpoint Test A.

Tip-in moan

Possible Source(s):

- Air cleaner
- Power steering (PS)
- Powertrain
- Engine mounts
- Exhaust system

Action(s) to take:

- GO to Pinpoint Test B.

Idle boom/shake/vibration, or shudder

Possible Source(s):

- Cable(s)/hoses(s)
- Engine mounts
- Exhaust system
- Belt/pulleys

Action(s) to take:

- GO to Pinpoint Test C.

Wheel end vibration analysis

Possible Source(s):

- Suspension/front or rear wheel drive half shaft and joints
- Tires/wheels
- Wheel bearings
- Front or rear wheel drive half shaft joint boots

Action(s) to take:

- GO to Pinpoint Test D.

Non-axle noise

Possible Source(s):

- Trim/mouldings
- A/C system
- Accessories

Action(s) to take:

- GO to Pinpoint Test E.

Pinpoint Tests**NOTE:**

These Pinpoint Tests are designed to take the technician through a step-by-step diagnosis procedure to determine the cause of a condition. It may not always be necessary to follow the chart to its conclusion. Carry out only the Pinpoint Test steps necessary to correct the condition. Then check operation of the system to make sure the condition is corrected.

After verifying that the condition has been corrected, make sure all components removed have been installed.

PINPOINT TEST G92216p1 : HIGH-SPEED SHAKE**G92216t1 : NEUTRAL COAST**

1. Carry out the neutral coast test.

- Does the vibration disappear during the neutral coast test?

-> **Yes**

CHECK and INSTALL new engine/gearbox/transfer box mounts as necessary. REPEAT Road Test as outlined.

-> **No**

GO to Pinpoint Test [G92216t9](#).

PINPOINT TEST G92216p2 : TIP-IN MOAN**G92216t2 : CHECK THE AIR CLEANER**

1. Check the air cleaner.

Check the air cleaner, inlet tube, outlet tube, resonators and all other components associated with the air induction system for correct installation and tightness of all connections.

- Are the components OK?

-> **Yes**

GO to Pinpoint Test [G92216t3](#).

-> **No**

CORRECT the condition. REPEAT the Road Test as outlined.

G92216t3 : CHECK THE EXHAUST SYSTEM

1. Carry out the exhaust system neutralizing procedure in this section.

- Is the exhaust system OK?

-> **Yes**

GO to Pinpoint Test [G92216t4](#).

-> **No**

REPAIR as necessary. RESTORE vehicle. REPEAT the Road Test as outlined.

G92216t4 : CHECK THE POWER STEERING

1. Remove the auxiliary drive belt and test for tip-in moan.

- Is the tip-in moan OK?

-> **Yes**

REPAIR the power steering as necessary. For additional information, refer to

-> **No**

CHECK and INSTALL new engine/gearbox/transfer box mounts as necessary. REPEAT Road Test as outlined.

PINPOINT TEST G92216p3 : IDLE BOOM/SHAKE/VIBRATION/SHUDDER

G92216t5 : CHECK CABLE/HOSES

1. Check the engine compartment for any component that may be grounding between the engine and body or chassis. Example: air conditioning (A/C) hoses.

- **Are the components OK?**

-> **Yes**

GO to Pinpoint Test [G92216t6](#).

-> **No**

CORRECT the condition. REPEAT the Road Test as outlined.

G92216t6 : CHECK THE DRIVER AIR BAG MODULE.

1. Remove the driver air bag module and visually inspect the for correct installation or any touch condition.

- **Is the driver air bag module OK?**

-> **Yes**

GO to Pinpoint Test [G92216t7](#).

-> **No**

CORRECT the condition. REPEAT the Road Test as outlined.

G92216t7 : CHECK THE COOLING RADIATOR

1. Check the engine cooling radiator mountings and bushings for security and condition. Check the radiator installation for any component that may have a touch condition.

- **Are the installation and bushings OK?**

-> **Yes**

GO to Pinpoint Test [G92216t8](#).

-> **No**

CORRECT the condition. REPEAT the Road Test as outlined.

G92216t8 : CHECK THE EXHAUST SYSTEM

1. Carry out the exhaust system neutralizing procedure in this section.

- **Is the exhaust system OK?**

-> **Yes**

CHECK and INSTALL new engine/gearbox/transfer box mounts as necessary. REPEAT Road Test as outlined.

-> **No**

REPAIR as necessary. REPEAT Road Test.

PINPOINT TEST G92216p4 : WHEEL END VIBRATION ANALYSIS

G92216t9 : INSPECT THE TIRES

1. Inspect the tires.

Raise and support the vehicle. For additional information, refer to [Lifting](#)

inspect the tires for:

correct tire size

tire/wheel compatibility

wear or damage

tire beads correctly seated

- **Are the tires OK?**

-> **Yes**

GO to Pinpoint Test [G92216t10](#).

-> **No**

INSPECT the wheels. For additional information, refer to [Wheels and Tires](#)

G92216t10 : INSPECT WHEEL BEARINGS

1. Inspect the wheel bearings. For additional information, refer to [Wheel Bearing Inspection](#)

- **Are the wheel bearings OK?**

-> **Yes**

GO to Pinpoint Test [G92216t11](#).

-> **No**

REPAIR as necessary. REPEAT the Road Test as outlined.

G92216t11 : INSPECT THE REAR WHEEL DRIVE HALF SHAFT JOINT BOOTS

1. Inspect the rear wheel drive half shaft joint boots.

spin the rear tire by hand

inspect for evidence of cracks, tears, splits or splattered grease

- **Are the rear wheel drive half shaft joint boots OK?**

-> **Yes**

GO to Pinpoint Test [G92216t12](#).

-> **No**

REPAIR as necessary. REPEAT the Road Test as outlined.

G92216t12 : INSPECT THE FRONT WHEEL DRIVE HALF SHAFT JOINT BOOTS

1. Inspect the front wheel drive half shaft joint boots

spin the front tire by hand

inspect for evidence of cracks, tears, splits or splattered grease

- **Are the front wheel drive half shaft joint boots OK?**

-> **Yes**

GO to Pinpoint Test [G92216t13](#).

-> **No**

REPAIR as necessary. REPEAT the Road Test as outlined.

G92216t13 : INSPECT WHEEL AND TIRE RUNOUT

1. Inspect the wheel and tire runout.

Carry out the Wheel and Tire Check procedure. For additional information, refer to [Wheels and Tires](#)

- **Is the wheel and tire runout OK?**

-> **Yes**

Balance the wheels and tires. Refer to the wheel balance equipment manufacturers instructions.

-> **No**

REPAIR as necessary. REPEAT the Road Test as outlined.

PINPOINT TEST G92216p5 : NON-AXLE NOISE

G92216t14 : INSPECT VEHICLE TRIM

1. Check the grille and trim mouldings to see if they are the source of the noise.

- **Are the vehicle trim components causing the noise?**

-> **Yes**

INSTALL new trim or REPAIR as necessary. For additional information, refer to

-> **No**

GO to Pinpoint Test [G92216t15](#).

G92216t15 : CHECK THE A/C SYSTEM FOR NOISE

1. Check the A/C system components for noise by turning the A/C system on and off.

- **Is the A/C system causing the noise?**

-> **Yes**

Diagnose the A/C system. For additional information, refer to [Climate Control System](#)

-> **No**

GO to Pinpoint Test [G92216t16](#).

G92216t16 : CHECK NON-FACTORY ACCESSORIES

1. Inspect any accessories for being the source of the noise. Example: grounding body-to-frame, antennas, visors, bug deflectors and fog lights?

- **Are the accessories the cause of the noise?**

-> **Yes**

ADJUST, REPAIR or INSTALL new accessories or fasteners as required.

-> **No**

Verify the customer concern