

SERVICE

TECHNICAL BULLETIN

Telephone Inoperative –
Incorrect Telematics Harness –
Check/Repair Procedure

MODEL 2004 MY
XJ range
VIN G00814-G18356

Remove and destroy Bulletin XJ419-02, dated 03/04.
Replace with this Bulletin.
Revisions are marked with a bar and in bold text.

Issue:

On some 2004 MY XJ range vehicles within the above VIN range, there is a possibility that an incorrect telematics harness was installed during production. This harness would prevent operation of the dealer installed telephone.

Action:

Before beginning with the telephone installation, check to see if the correct telematics harness is installed, and install a new telematics harness if required. Follow the workshop procedure outlined below.

WORKSHOP PROCEDURE

Check to see if the correct telematics harness is installed:

1. Remove floor console rear vent to identify if the telematics harness requires changing.

Note: The incorrect telematics harness has only one grey connector. The correct telematics harness has two grey connectors.

Illustration 1 shows the position of the telematics harness in the vehicle.

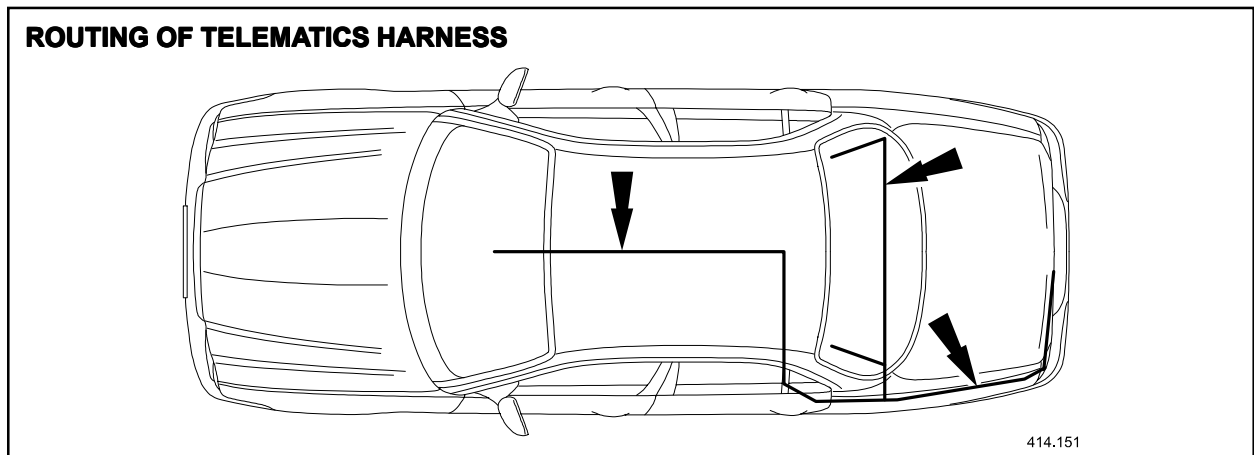

ILLUSTRATION 1

NOTE: THE INFORMATION IN TECHNICAL BULLETINS IS INTENDED FOR USE BY TRAINED, PROFESSIONAL TECHNICIANS WITH THE KNOWLEDGE, TOOLS, AND EQUIPMENT TO DO THE JOB PROPERLY AND SAFELY. IT INFORMS THESE TECHNICIANS OF CONDITIONS THAT MAY OCCUR ON SOME VEHICLES, OR PROVIDES INFORMATION THAT COULD ASSIST IN PROPER VEHICLE SERVICE. THE PROCEDURES SHOULD NOT BE PERFORMED BY "DO-IT-YOURSELFERS." DO NOT ASSUME THAT A CONDITION DESCRIBED AFFECTS YOUR CAR. CONTACT A JAGUAR RETAILER TO DETERMINE WHETHER THE BULLETIN APPLIES TO YOUR VEHICLE.

If necessary, remove telematics harness:

2. Remove front seats (see Workshop Manual, JTIS CD ROM, section: 501-10, SRO 76.70.01).

Note: When disconnecting the battery, remove the luggage compartment carpet.

3. Remove floor console (see Workshop Manual, JTIS CD ROM, section: 501-12, SRO 76.25.01).
4. Remove rear parcel shelf (see Workshop Manual, JTIS CD ROM, section: 501-05, SRO 76.67.06).
5. Remove instrument panel console (see Workshop Manual, JTIS CD ROM, section: 501-12, SRO 88.20.34).

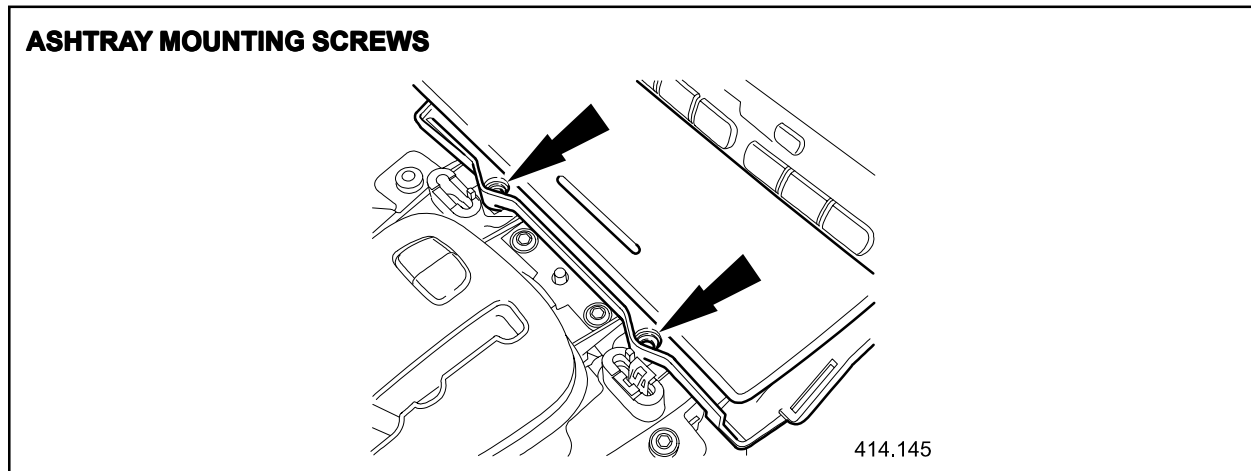

ILLUSTRATION 2

6. Displace and remove ashtray plastic covers, remove screws. (Illustration 2).

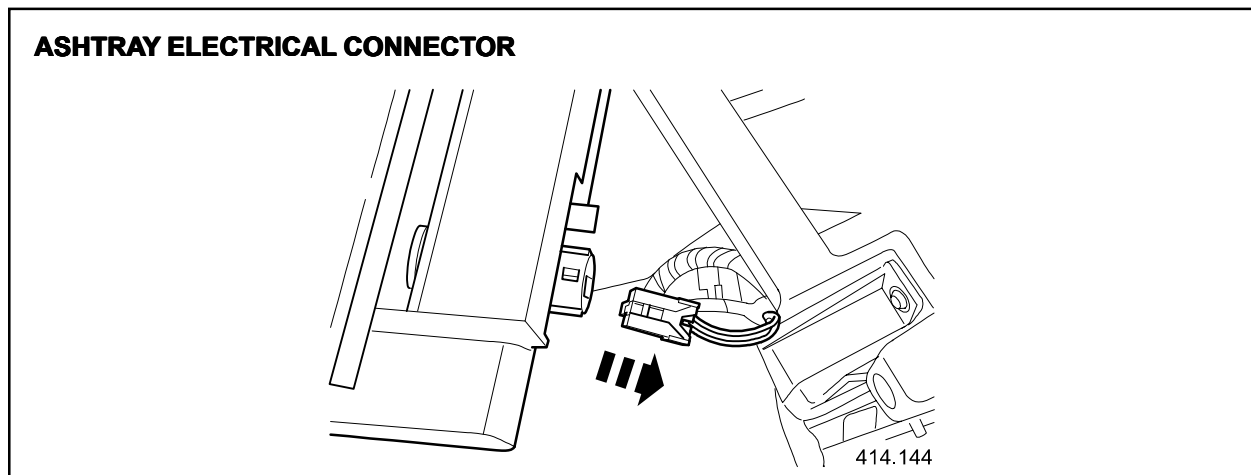

ILLUSTRATION 3

7. Displace the ashtray and disconnect the electrical connector and place ashtray aside (Illustration 3).
8. Remove front scuff plate trim panel (see Workshop Manual, JTIS CD ROM, section: 501-05, SRO 76.13.22).

9. Remove rear scuff plate trim panel (see Workshop Manual, JTIS CD ROM, section: 501-05, SRO 76.13.22).
10. Remove B-pillar lower trim panel (see Workshop Manual, JTIS CD ROM, section: 501-05, SRO 76.13.29).
11. Remove rear floor carpet.
12. Displace and remove left-hand C-pillar lower trim (see Workshop Manual, JTIS CD ROM, section: 501-05).
13. Disconnect left-hand rear seat belt buckle electrical connector.
14. Remove left-hand rear seat backrest lower support bracket securing nuts.
15. Remove left-hand rear seat belt buckles, feed electrical connector under insulation pad.
16. Remove left-hand rear seat backrest lower support bracket.
17. Displace and remove cabin rear insulating pad upper left-hand plastic clip.
18. Fold left-hand side of insulating pad over to right-hand side of cabin. Feed fly leads through openings in insulating pad.

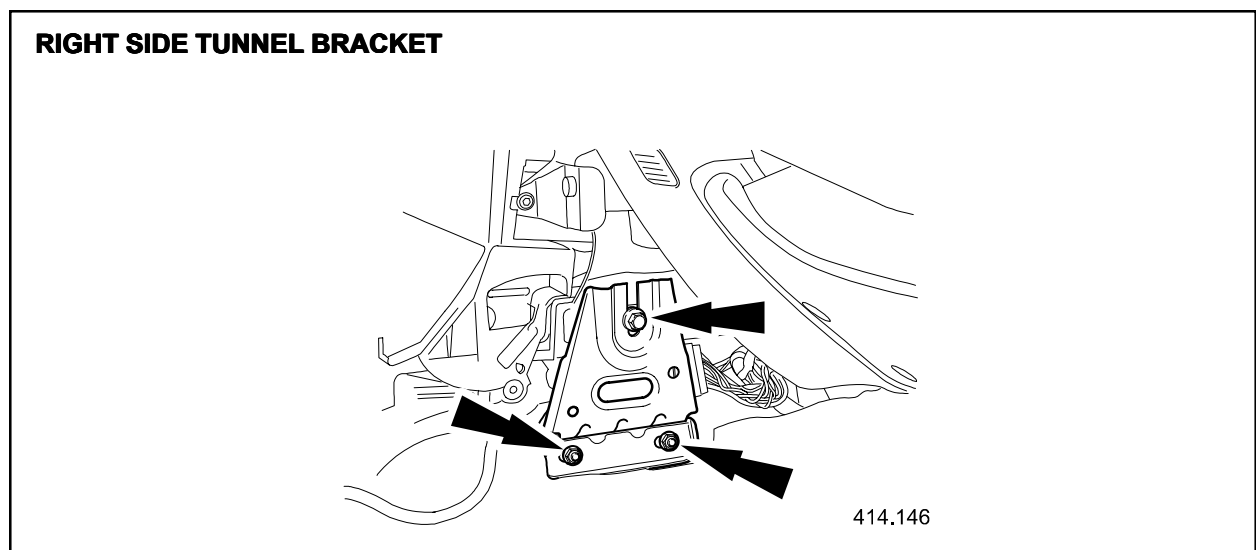
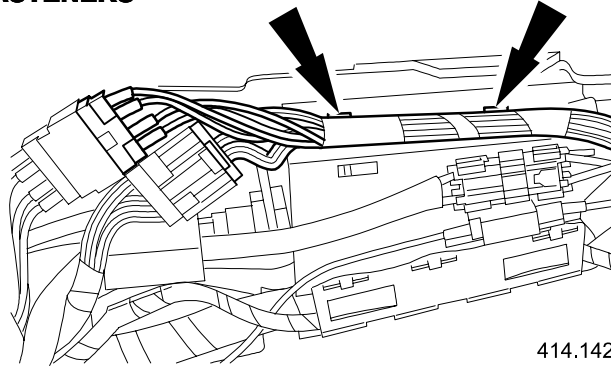

ILLUSTRATION 4

19. Remove right-hand side tunnel bracket securing nuts and screw (Illustration 4).
20. Reposition right-hand side tunnel bracket for access.
21. Displace and remove bracket from electrical connector fir tree fastener.

HARNESS FIR TREE FASTENERS



414.142

ILLUSTRATION 5

22. Displace upper harness fir tree fasteners from the telematics harness front plastic support (Illustration 5).

REPOSITION LOWER HARNESS

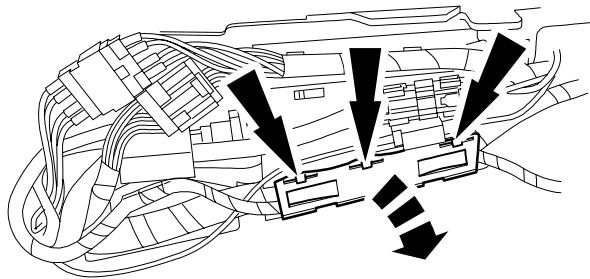

414.149

ILLUSTRATION 6

- 23 Open telematics harness front plastic support flap and reposition lower harness from support (Illustration 6).

REPOSITION UPPER AND LOWER HARNESSES

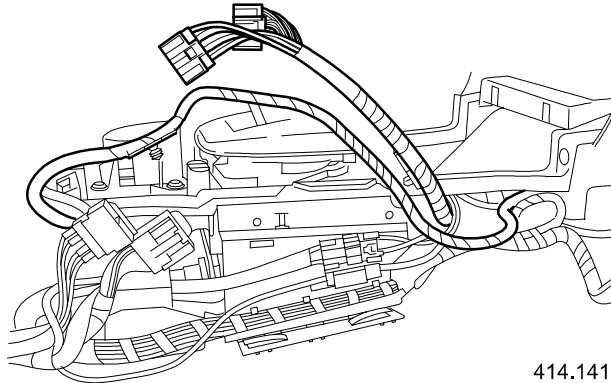

414.141

ILLUSTRATION 7

- 24 Displace the lower harness fir tree fastener from the front plastic support of the telematics harness. Reposition upper and lower harnesses (Illustration 7).

25. Remove foam pads from each side of rear shelf.
26. Displace telematics harness fir tree fasteners from rear shelf.

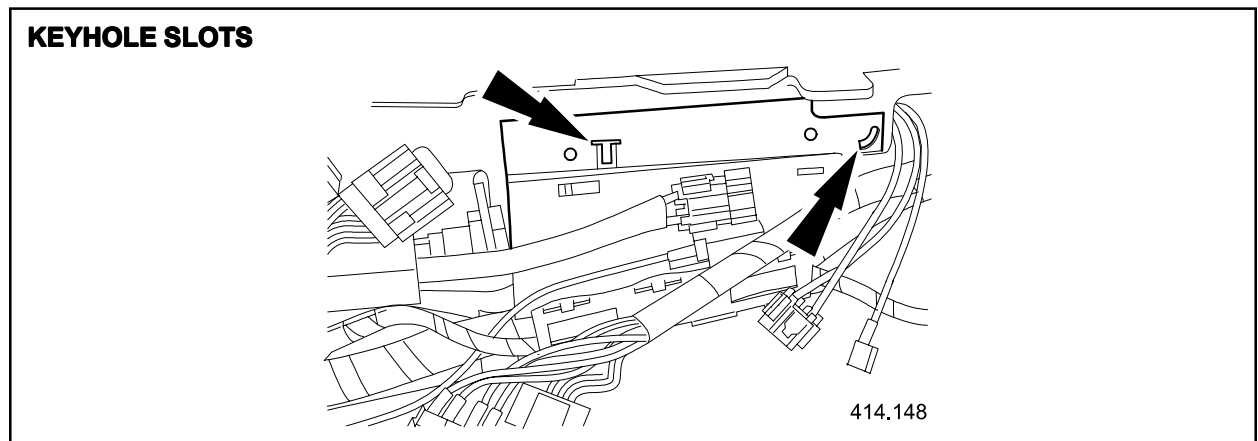

ILLUSTRATION 8

27. Displace the front plastic support of the telematics harness from the keyhole slots of the aluminum frame mounted on the tunnel (Illustration 8).
28. Displace telematics harness plastic support from tunnel studs.
29. Displace telematics harness plastic support from rear seat pan studs.
30. Displace telematics harness from harness fir tree fasteners at rear seat back panel.
31. Displace telematics harness connector fir tree fasteners from top left-hand corner of the rear seat back panel.
32. Keep a record and disconnect all remaining telematics harness electrical connectors in cabin.
33. Displace harness from the telematics harness through panel plastic support side clips.
34. Displace the telematics harness through panel plastic support fir tree fasteners from the rear seat back panel.

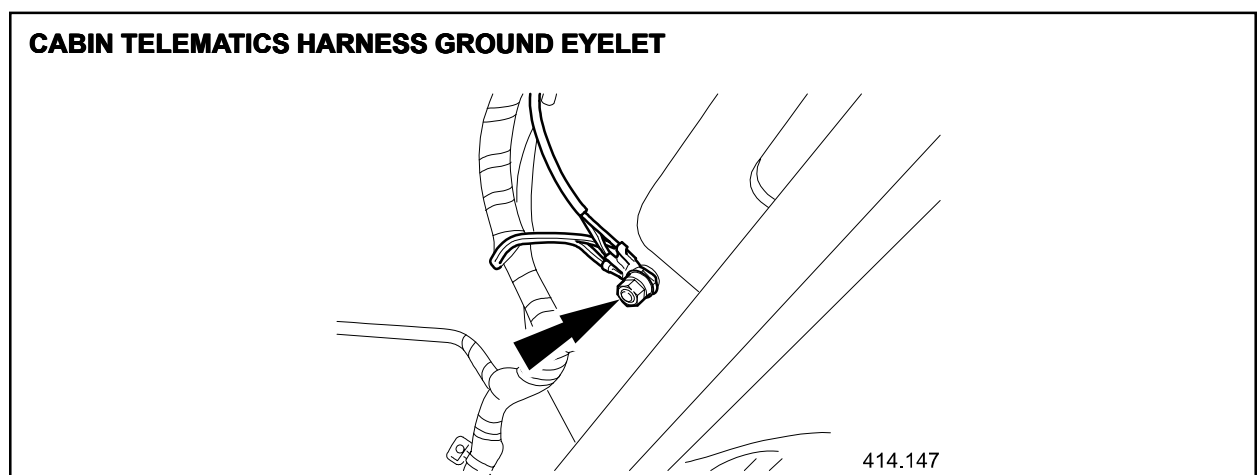

ILLUSTRATION 9

35. Remove telematics harness ground eyelet securing nut in the cabin (Illustration 9), and disconnect ground eyelet from stud.

Working in the luggage compartment:

36. Remove luggage compartment front liner.
37. Remove luggage compartment left-hand side liner.
38. Remove luggage compartment right-hand side liner.
39. Remove foam pad from left-hand air spring studs.
40. Unclip the two telematics harness electrical connector fir tree fasteners at rear of spare wheel well.
41. Disconnect the two telematics harness electrical connectors.

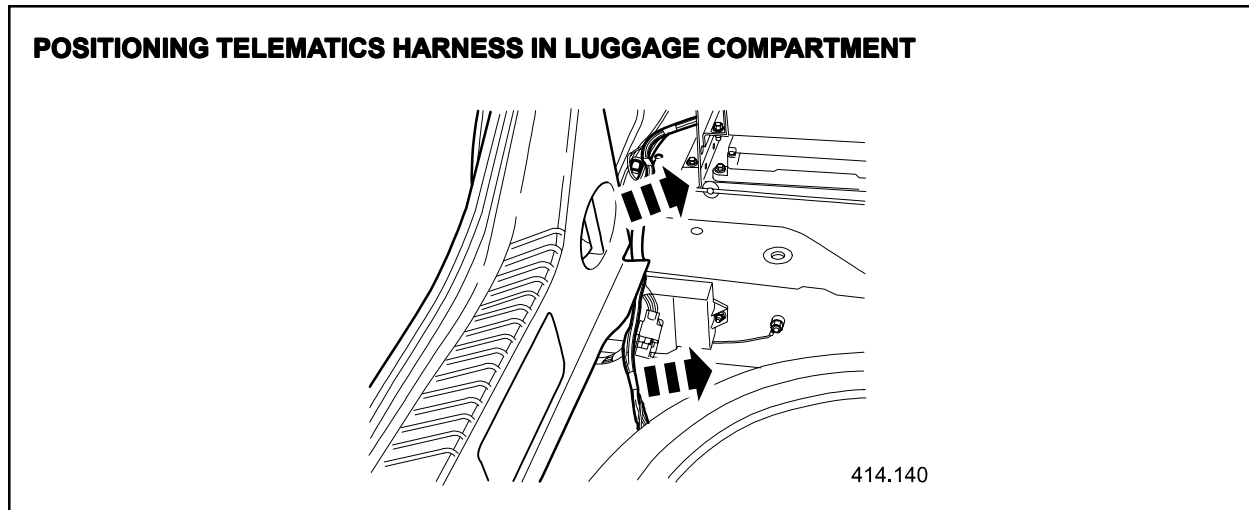

ILLUSTRATION 10

42. Remove the luggage compartment rear plastic panel left-hand securing screw. Reposition the rear plastic panel lower left-hand corner forward and carefully reposition the telematics harness past the lower corner of the rear plastic panel into luggage compartment (Illustration 10).
43. Release the lower corner of the rear plastic panel.

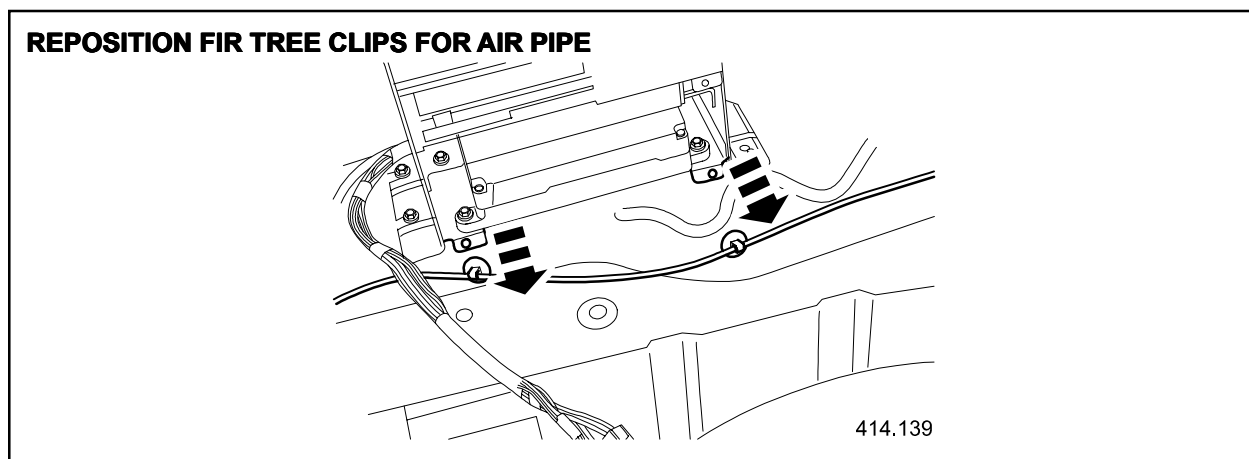

ILLUSTRATION 11

44. Displace left-hand rear suspension air pipe fir tree clips from the entertainment stack (Illustration 11).
45. Unclip the air pipe from the telematics harness rear plastic support clips.

46. Loosen the rear screws securing the entertainment stack to the body.
47. Remove the front screws securing the entertainment stack to the body.
48. Reposition entertainment stack for access.
49. Disconnect all electrical connectors from the entertainment stack.
50. Displace telematics harness fir tree fastener from the entertainment stack frame.
51. Remove the entertainment stack from the boot.
52. Displace the telematics harness through panel plastic support from the rear seat back panel.
53. Keep a record and disconnect all remaining telematics harness electrical connectors in the luggage compartment.
54. Remove telematics harness ground eyelet securing nut in the luggage compartment (Illustration 12), and disconnect ground eyelet from stud.

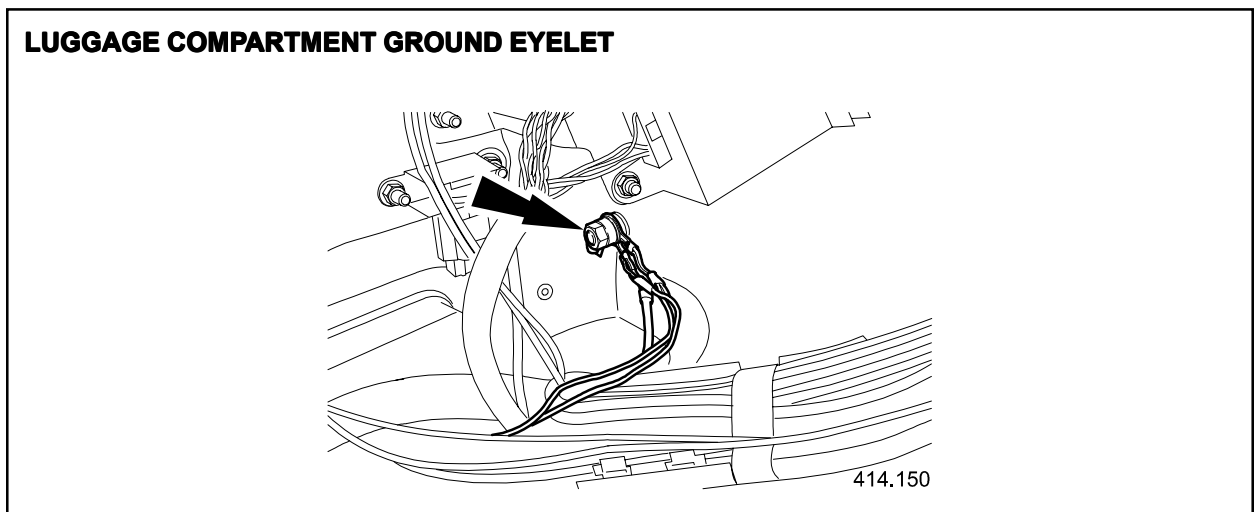

ILLUSTRATION 12

55. Remove the telematics harness from inside the cabin of the vehicle.
56. To install the new telematics harness, reverse the removal procedure.

Global Technical Reference (GTR):

Dealer Access: <https://hub.franchise.jaguar.com>

Internet access: <http://www.jaguartechno.com>

Parts Information:

DESCRIPTION	PART NUMBER	QTY
Telematics harness with voice activated controls, with telephone prep pack design B, without navigation	C2C 23813	1
Telematics harness with rear seat radio control, with voice activated controls, with telephone prep pack design B, with rear-entertainment system, without navigation	C2C 25045	1
Telematics harness with voice activated controls, with telephone prep pack design B, without navigation, with out rear-entertainment system	C2C 23817	1
Telematics harness with voice activated controls, with telephone prep pack design B, without adaptive control damping, without rear seat radio control, without navigation, without Jaguar sound system, without emergency message system centre, without rear-entertainment system	C2C 20668	1
Telematics harness with navigation, with voice activated controls, with telephone prep pack design B, with rear-entertainment system, without rear seat radio control	C2C 23829	1
Telematics harness with premium in car entertainment, with navigation, with voice activated controls, with telephone prep pack design B, with rear-entertainment system	C2C 20679	1
Telematics harness with navigation, with voice activated controls, with telephone prep pack design B, without rear-entertainment system	C2C 23835	1

Warranty Information:

Description	SRO	Time	Causal Part Number
Install a new telematics harness	86.93.34	5.1 hrs.	C2C 20668