

Driveshaft Vibration –  
Diagnostic Method –  
Repair

MODEL 2002-04 MY  
X-TYPE

VIN C00001-E02938

Remove and destroy Bulletin XT100-08, dated 05/04.  
Replace with this Bulletin.  
Revisions are marked with a bar and in bold text.

**Issue:**

A new procedure has been developed for use after the WDS Vehicle Vibration Analyzer (VVA) has confirmed a vehicle vibration.

**Action:**

After a driveshaft vibration has been confirmed using WDS VVA, follow the workshop procedure outlined below.

WORKSHOP PROCEDURE

**Note:** There is no Labor Time Allowance to carry out road test diagnosis. Jaguar recommends a claim of 0.50 hrs. as straight time for VVA.

**Warning:** Driveshaft bolts are one-time use only. Use **new bolts** for the final repair. Existing bolts may be reused throughout the diagnostic procedures.

1. Raise vehicle on twin-post lift.
2. Check for alignment of the green line on the rear differential flange with white paint spot on the rear of the driveshaft. If not aligned continue from step 3; if aligned continue from step 16.
3. Remove the rear driveshaft joint to rear differential flange bolts and links where accessible.
4. Rotate the driveshaft and remove the remaining rear driveshaft joint to rear differential flange securing bolts and links.
5. Displace driveshaft from the rear differential flange.
6. Remove and discard the gasket from the rear differential flange (where installed).
7. Clean the mating faces.
8. Install a new gasket to the rear differential flange, if previously installed.

NOTE: THE INFORMATION IN TECHNICAL BULLETINS IS INTENDED FOR USE BY TRAINED, PROFESSIONAL TECHNICIANS WITH THE KNOWLEDGE, TOOLS, AND EQUIPMENT TO DO THE JOB PROPERLY AND SAFELY. IT INFORMS THESE TECHNICIANS OF CONDITIONS THAT MAY OCCUR ON SOME VEHICLES, OR PROVIDES INFORMATION THAT COULD ASSIST IN PROPER VEHICLE SERVICE. THE PROCEDURES SHOULD NOT BE PERFORMED BY "DO-IT-YOURSELFERS." DO NOT ASSUME THAT A CONDITION DESCRIBED AFFECTS YOUR CAR. CONTACT A JAGUAR RETAILER TO DETERMINE WHETHER THE BULLETIN APPLIES TO YOUR VEHICLE.

9. Rotate the driveshaft and rear differential flange so the colored markings are aligned to each other.
10. Position the driveshaft to the rear differential flange.
11. Install, but do not final-tighten the accessible bolts and links that secure the rear driveshaft joint to the rear differential flange.
12. Rotate driveshaft and install, but do not final-tighten, the remaining bolts and links that secure the rear driveshaft joint to the rear differential flange.
13. With the driveshaft joint fully seated in the rear differential flange, final tighten the accessible securing bolts to 44 Nm (32 lb. ft.).
14. Rotate driveshaft and final tighten the bolts securing the driveshaft to the rear differential flange to 44 Nm (32 lb. ft.).
15. Lower vehicle on ramp.

*If the VVA still confirms a driveshaft vibration, or the paint marks were already aligned:*

16. Loosen the 6 bolts at the rear differential flange/driveshaft mating surface. Reseat the driveshaft and retorque to 44 Nm (32 lb. ft.).

**Note:** Ensure colored marks are aligned at the rear differential.

17. If the VVA still confirms a driveshaft vibration, install a new driveshaft (see Workshop Manual, section: 205-01, SRO 47.15.01).

**Note:** Ensure colored marks are aligned at the rear differential.

If the VVA still confirms a driveshaft vibration on vehicles from VIN C00001-D80862 check the flange inside diameter and run-out as described below. On vehicles from VIN D80862-E02938, contact the Technical Helpline at 1-888-JagDlrs.

#### CHECKING FLANGE ID AND RUNOUT - VIN C00001-D80862 ONLY

1. Raise vehicle on twin-post ramp.
2. Remove driveshaft (see Workshop Manual, section: 205-01, SRO 47.15.01).
3. Clean mating faces.
4. Using a suitable measuring device, measure and record the rear differential driveshaft locating flange **inside diameter** (Illustration 1).

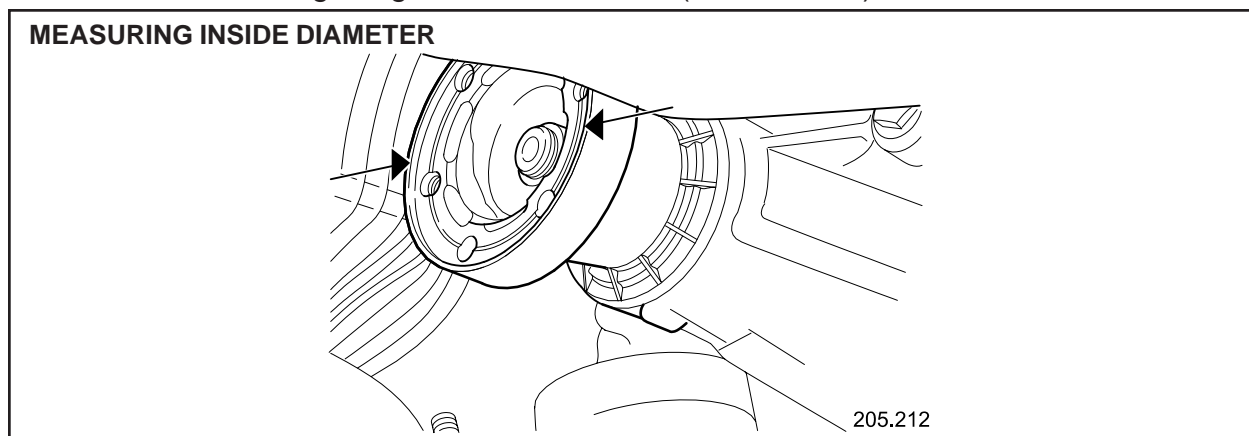

ILLUSTRATION 1

5. Mount a suitable magnetic base dial indicator and mount on the rear differential.
6. Measure and record the rear differential driveshaft locating flange **inside diameter** run-out (Illustration 2).

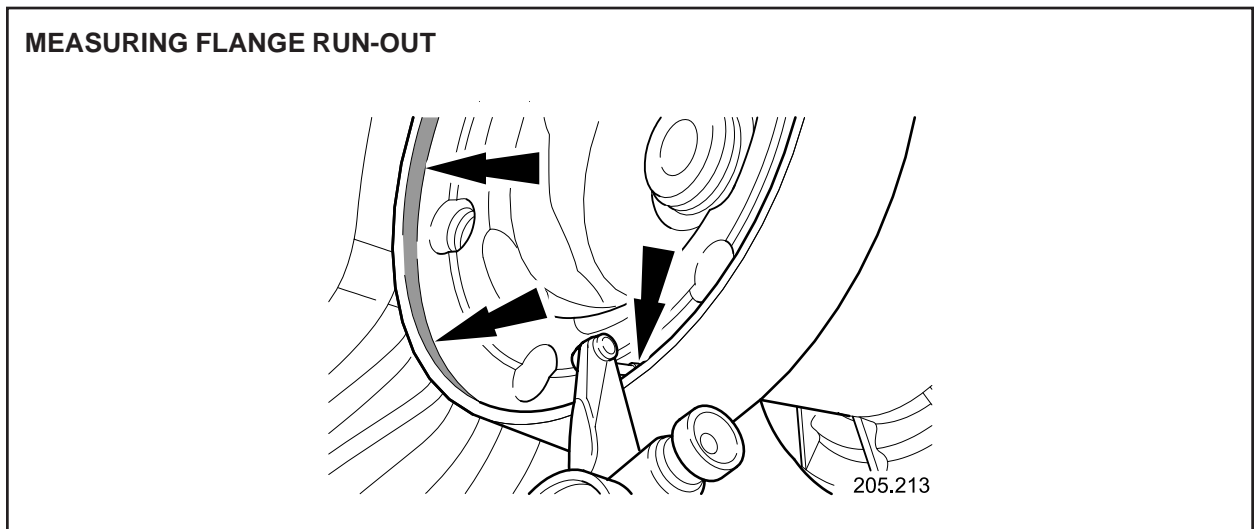

ILLUSTRATION 2

7. If the inside diameter is greater than 94.076 mm or less than 94.030 mm and/or the run-out is greater than 0.12 mm, install a new drive pinion flange and seal (see Workshop Manual, section: 205-02, SRO 51.25.13).

**Note:** Ensure colored marks are aligned at the rear differential.

If the inside diameter is between 94.076 mm and 94.030 mm and/or the run-out is less than 0.12 mm, contact the Technical Helpline at 1-888-JagDlrs.

## Global Technical Reference (GTR):

Dealer Access: <https://hub.franchise.jaguar.com>

Internet access: <http://www.jaguartechno.com>

### Parts Information:

<u>DESCRIPTION</u>	<u>PART NUMBER</u>	<u>QTY</u>
Driveshaft - All vehicles	C2S 38561	1
Driveshaft bolts - All vehicles	C2S 16374	As required
Link washers - All vehicles	C2S 4724	As required
Driveshaft flange gasket - Up to D55321	C2S 22210	As required
Center bearing fixing - All vehicles	C2S 3621	As required
<b>Rear drive pinion flange - All vehicles</b>	<b>C2S 4900</b>	<b>1</b>
<b>Rear drive pinion seal - All vehicles</b>	<b>C2S 4918</b>	<b>1</b>
<b>Rear drive pinion flange retaining nut - All vehicles</b>	<b>C2S 1537</b>	<b>1</b>
Rear drive axle/differential oil - All vehicles	JLM 20771	As required
Brake caliper retaining bolts - All vehicles	C2S 15593	2 per side
<b>Rear drive axle/differential rear bolt - All vehicles</b>	<b>C2S 18302</b>	<b>1</b>
<b>Rear drive axle/differential rear washer - All vehicles</b>	<b>C2S 19258</b>	<b>1</b>

### Warranty Information:

Warranty claims should be submitted quoting the information found in the table below. This will result in payment of the stated time and, where applicable parts/miscellaneous expense codes as listed.

Description	SRO	Time	Causal Part Number
Check align paint marks - driveshaft to the rear drive axle/differential flange	47.91.10	0.3 hrs.	C2S 26150
Remove driveshaft from vehicle and re-install	47.15.01	1.0 hrs.	C2S 26150
Install a new driveshaft	47.15.01	1.0 hrs.	C2S 26150
Measure rear drive axle/differential flange internal diameter and run-out	47.91.10/01	0.2 hrs.	<b>C2S 4900</b>
<b>Install a new rear drive pinion seal and flange</b>	<b>51.20.01</b>	<b>1.9 hrs.</b>	<b>C2S 4900</b>