

ZF

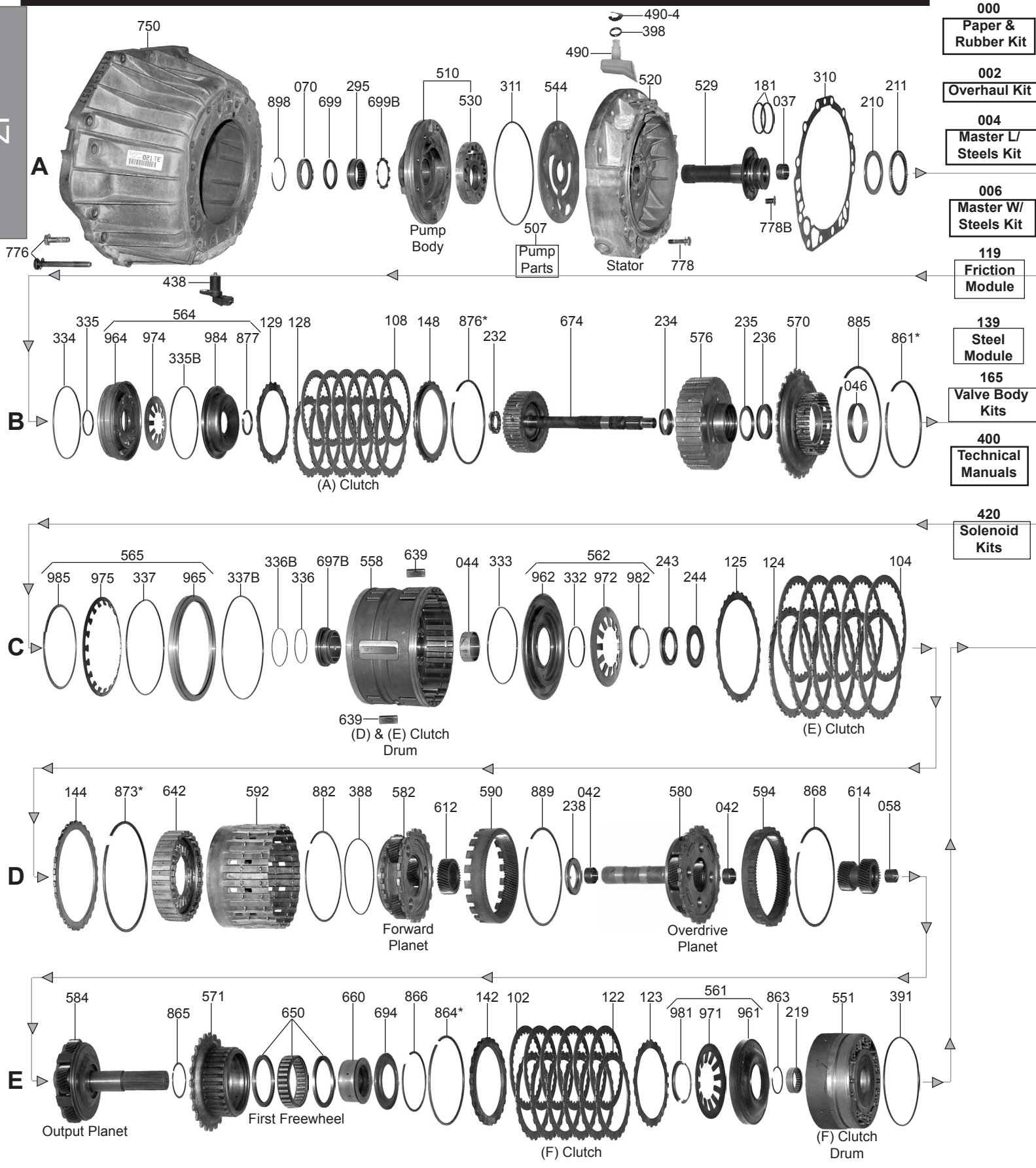

000 Paper & Rubber Kit

002 Overhaul Kit

004 Master L/ Steels Kit

006 Master W/ Steels Kit

119 Friction Module

139 Steel Module

165 Valve Body Kits

400 Technical Manuals

420 Solenoid Kits

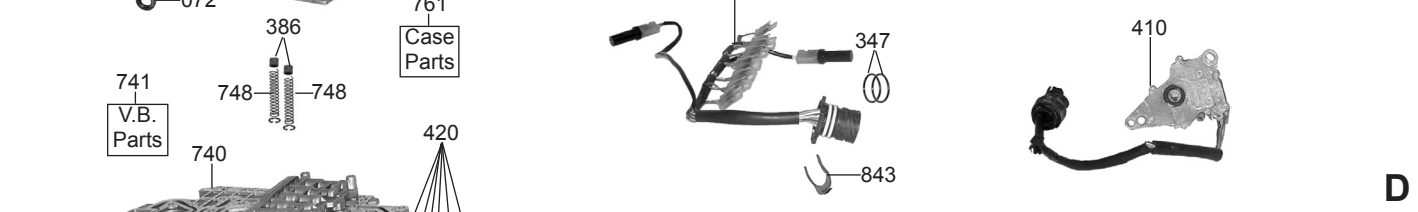
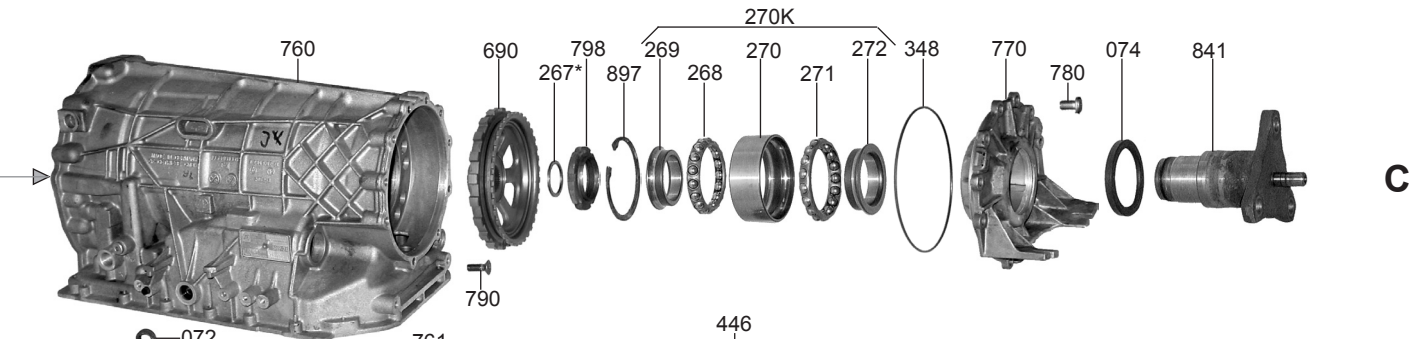
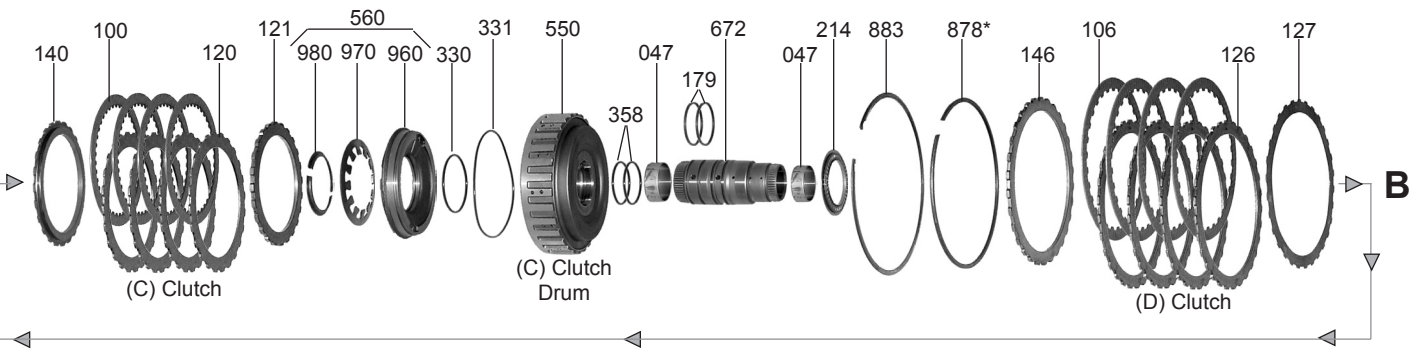
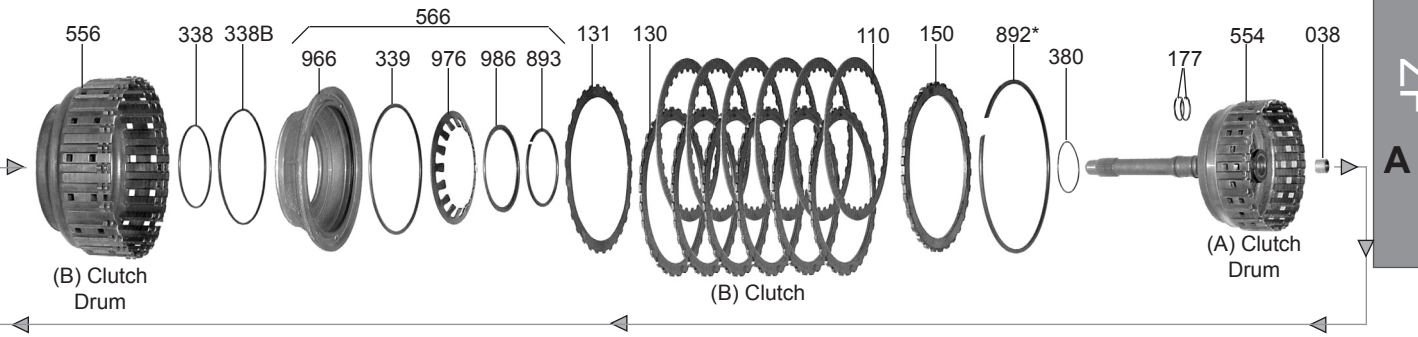

ZF

PART #	PAPER & RUBBER KIT	QTY	REFERENCE #
148000A	Paper & Rubber Kit, ZF5HP24 5 Speed	1	

PART #	OVERHAUL KIT	QTY	REFERENCE #
148002A	Overhaul Kit, ZF5HP24A (Audi/Volkswagen)(AWD) 1994-Up (For 4 Clutch Bonded Piston Sell 148962B)	1	
148002B	Overhaul Kit, ZF5HP24 (BMW/Jaguar/Range Rover) 1995-Up (For F Clutch Bonded Piston Sell 148961B)(For Range Rover You Must Sell 190074A Also)	1	

PART #	MASTER L/STEELS KIT	QTY	REFERENCE #
148004A	Master L/Steels Kit, ZF5HP24A (Audi/VW) (AWD) 1994-Up (For F Clutch Bonded Piston Sell 148961B) (For Units Ending In 004/007)	1	
148004AA	Master L/Steels Kit, ZF5HP24A (Audi/VW) (AWD) 1994-Up (For F Clutch Bonded Piston Sell 148961B) (For Units Ending In All Numbers Except 004/007)	1	
148004B	Master L/Steels Kit, ZF5HP24 (BMW/Jaguar/Range Rover) 1995-Up (For F Clutch Bonded Piston Sell 148961B) (For Units Ending In 005/009/032)(For Range Rover You Must Sell 190074A Also)	1	
148004BA	Master L/Steels Kit, ZF5HP24 (BMW/Jaguar) 1995-Up (For F Clutch Bonded Piston Sell 185961B) (For Units Ending In All Numbers Except 005/009/032)	1	

PART #	MASTER W/STEELS KIT	QTY	REFERENCE #
148006A	Master W/Steels Kit, ZF5HP24A (Audi/VW) (AWD) 1994-Up (For F Clutch Bonded Piston Sell 148961B) (For Units Ending In 004/007)	1	
148006AA	Master W/Steels Kit, ZF5HP24A (Audi/VW) (AWD) 1994-Up (For F Clutch Bonded Piston Sell 148961B) (For Units Ending In All Numbers Except 004/007)	1	
148006B	Master W/Steels Kit, ZF5HP24 (BMW/Jaguar/Range Rover) 1995-Up (For F Clutch Bonded Piston Sell 148961B) (For Units Ending In 005/009/032)(For Range Rover You Must Sell 190074A Also)	1	
148006BA	Master W/Steels Kit, ZF5HP24 (BMW/Jaguar) 1995-Up (For F Clutch Bonded Piston Sell 148961B) (For Units Ending In All Numbers Except 005/009/032)	1	

PART #	FILTERS	QTY	REFERENCE #
148010A	Filter, ZF5HP24A (Audi A8) (With 1.045" Long Round Pick-Up Tube) 1997-99	1	
148010AA	Filter, ZF5HP24A (Audi A6,A8/S6) (With .872" Long Round Pick-Up Tube) 1999-03	1	
148010B	Filter, ZF5HP24 (BMW/Jaguar/Landrover) With Oval Pick Up Tube 1997-Up	1	

PART #	BUSHINGS	QTY	REFERENCE #
148037B	Bushing, ZF5HP24 (BMW) Stator (Rear) .590" Wide (1.110"OD) 1.020"ID (Bronze) 1995-Up	1	
148038B	Bushing, ZF5HP24 (BMW) A Clutch Drum (Rear) .540" Wide (.560"ID) Bronze 1995-Up	1	
148042B	Bushing, ZF5HP24 (BMW) Overdrive Planet (Front & Rear) (.376" Wide)(.985"OD)(.876"ID) 1995-Up	2	
148044B	Bushing, ZF5HP24 (BMW) D & E Clutch Drum (Rear) .320" Wide (2.000"OD) (1.780"ID) (Babbit) 1995-Up	1	
148046B	Bushing, ZF5HP24 (BMW) C Clutch Hub (2.602"ID) (Bronze) 1995-Up	1	
148047B	Bushing, ZF5HP24 (BMW) Sun Gear Shaft (.635" Wide) 1.415"OD (1.250"ID) Brass 1995-Up	2	
148058B	Bushing, ZF5HP24 (BMW) Output Planet (Front) .785"OD (.675"ID) Brass With Oil Pockets 1995-Up	1	

PART #	METAL CLAD SEALS	QTY	REFERENCE #
44070	Seal, ZF5HP24 Front (2.060"OD) 1995-Up	1	
128072A	Seal, ZF5HP24 Linkage (BMW) 1995-Up (.710"OD)	1	
128074A	Seal, ZF5HP24 Extension Housing (2WD) 2.885"OD (.322" Thick) 1995-Up	1	
190074A	Seal, ZF5HP24 (Range Rover Units Ending In 032) (2.450"OD)(.280" Thick) 2003-Up	1	

PART #	FRICTION CLUTCH	QTY	REFERENCE #
44100	Friction, ZF5HP24 A Clutch #108 & C Clutch #100 (.061" Thick) 40 Teeth 1995-Up	4-10	
148102B	Use 128102A	6	
128102A	Friction, ZF5HP24 (BMW) F Clutch (.062")(30 Teeth)(5.627"OD) 1995-Up	6	
148104B	Use 148110B	5	

148106B	Use 148110B	4	
148108B	Use 44100	6	
148110B	Friction, ZF5HP24 (BMW) B Clutch (.063" Thick) 30 Teeth (7"OD) 1995-Up (Also Fits ZF5HP24 (BMW) D Clutch #106 1995-Up) (Also Fits ZF5HP24 (BMW) E Clutch #104 1995-Up)	4-15	
148119A	Friction Module, ZF5HP24 / ZF5HP24A 1994-Up (For Units Ending In 005/009 In The 5HP24 Series Or 004/007 In The 5HP24A Series)	1	
148119AA	Friction Module, ZF5HP24 / ZF5HP24A 1994-Up (For Units Ending In All Numbers Except 004/005/007/009)	1	

PART #	STEEL CLUTCH	QTY	REFERENCE #
--------	--------------	-----	-------------

148120B	Use 148128B	4	
148121B	Use 148129B	1	
128122A	Steel, ZF5HP24 F Clutch #122 (.071" Thick) 24 Teeth (4.688"ID) 1995-Up		
148122B	Use 128122A	6	
148123B	Steel, ZF5HP24 (BMW) F Clutch (.032") 24 Teeth (4.705"ID) Waved 1995-Up	1	
148124B	Use 148130B	5	
148125B	Use 148131B	1	
148126B	Use 148130B	4	
148127B	Use 148131B	1	
148128B	Steel, ZF5HP24 (BMW) A Clutch (.082" Thick) 24 Teeth (4.206"ID) 1995-Up (Also Fits ZF5HP24 (BMW) C Clutch 1995-Up)	4-10	
148129B	Steel, ZF5HP24 (BMW) A Clutch (.043" Thick) 24 Teeth (4.210"ID) Waved 1995-Up (Also Fits ZF5HP24 (BMW) C Clutch #121 1995-Up)	1-2	
148130B	Steel, ZF5HP24 (BMW) B Clutch (.118" Thick) 30 Teeth (6 1/8"ID) 1995-Up (Also Fits ZF5HP24 (BMW) D Clutch #126 1995-Up) (Also Fits ZF5HP24 (BMW) E Clutch #124 1995-Up)	4-15	
148131B	Steel, ZF5HP24 (BMW) B Clutch (.037" Thick) 30 Teeth (6 1/8"ID) Waved 1995-Up (Also Fits ZF5HP24 (BMW) D Clutch #127 1995-Up)(Also Fits ZF5HP24 (BMW) E Clutch #125 1995-Up)	1-3	
148139A	Steel Module, ZF5HP24 / ZF5HP24A 1994-Up (For Units Ending In 005/009 In The 5HP24 Series Or 004/007 In The 5HP24A Series)	1	
148139AA	Steel Module, ZF5HP24 / ZF5HP24A 1994-Up (For Units Ending In All Numbers Except 004/005/007/009)	1	

PART #	PRESSURE PLATES	QTY	REFERENCE #
--------	-----------------	-----	-------------

148140B	Pressure Plate, ZF5HP24 (BMW) C Clutch (.176") 24 Teeth (7.125:DO) 1995-Up	1	
148142B	Pressure Plate, ZF5HP24 (BMW) F Clutch (.238" Thick) 24 Teeth (4.684"ID) 1995-Up	1	
148144B	Use 148150B	1	
148146B	Use 148150B	1	
148148B	Pressure Plate, ZF5HP24 (BMW) A Clutch (.116" Thick) 24 Teeth (4.210"ID) Stepped 1995-Up	1	
148150B	Pressure Plate, ZF5HP24 (BMW) B Clutch (.153" Thick) 30 Teeth (6 1/8"ID) 1995-Up (Also Fits ZF5HP24 (BMW) D Clutch #146 1995-Up) (Also Fits ZF5HP24 (BMW) E Clutch #144 1995-Up)	1-3	

PART #	VALVE BODY KITS	QTY	REFERENCE #
--------	-----------------	-----	-------------

148165B	Valve Body Kit, ZF5HP24 1994-Up	1	1
---------	---------------------------------	---	---

PART #	SEALING RINGS	QTY	REFERENCE #
--------	---------------	-----	-------------

148177BT	Ring, ZF5HP24 (BMW) Input Shaft (Scarf Cut) (Teflon) 1995-Up	2	
148179BT	Ring, ZF5HP24 (BMW) Sun Gear Shaft (Scarf Cut) (Teflon) 1995-Up	2	
148181BT	Ring, ZF5HP24 (BMW) Stator To B Clutch Drum (.096" Thick) Lap Joint (Teflon) 1995-Up	2	

PART #	WASHERS & BEARINGS	QTY	REFERENCE #
--------	--------------------	-----	-------------

148210B	Race, ZF5HP24/ZF5HP24A Stator Tube To B Clutch Drum (.055" Thick) 2.875"OD (2.175"ID) 1995-Up	1	
148210BA	Race, ZF5HP24/ZF5HP24A Stator Tube To B Clutch Drum (.063" Thick) 2.875"OD (2.175"ID) 1995-Up	1	
148210BB	Race, ZF5HP24/ZF5HP24A Stator Tube To B Clutch Drum (.071" Thick) 2.875"OD (2.175"ID) 1995-Up	1	
148210BC	Race, ZF5HP24/ZF5HP24A Stator Tube To B Clutch Drum (.078" Thick) 2.875"OD (2.175"ID) 1995-Up	1	
148210BD	Race, ZF5HP24/ZF5HP24A Stator Tube To B Clutch Drum (.086" Thick) 2.875"OD (2.175"ID) 1995-Up	1	
148210BE	Race, ZF5HP24/ZF5HP24A Stator Tube To B Clutch Drum (.094" Thick) 2.875"OD (2.175"ID) 1995-Up	1	

ZF

PART #	WASHERS & BEARINGS (Continued)	QTY	REFERENCE #
148210BF	Race, ZF5HP24/ZF5HP24A Stator Tube To B Clutch Drum (.102" Thick) 2.875"OD (2.175"ID) 1995-Up	1	
148210BG	Race, ZF5HP24/ZF5HP24A Stator Tube To B Clutch Drum (.110" Thick) 2.875"OD (2.175"ID) 1995-Up	1	
148210BH	Race, ZF5HP24/ZF5HP24A Stator Tube To B Clutch Drum (.118" Thick) 2.875"OD (2.175"ID) 1995-Up	1	
148211B	Bearing, ZF5HP24/ZF4HP24A Stator Tube To B Clutch Drum (.149" Thick) 2.941"OD (2.285"ID) 1995-Up	1	
148214B	Bearing W/Race, ZF5HP24/Z5HP24A C Clutch Drum To D & E Clutch Drum (.137" Thick) 2.870"OD (1.900"ID) 1995-Up	1	
148219B	Caged Needle Bearing, ZF5HP24/ZF5HP24A In F Clutch Drum (.468" Thick) 1.655"OD 1995-Up	1	
148232B	Bearing W/Race, ZF5HP24/ZF5HP24A A Clutch Drum To Hub (.283" Thick) 1.508"OD (.645"ID) 1995-Up	1	
148234B	Bearing W/Race, ZF5HP24/ZF5HP24A A Clutch Hub To B Clutch Hub (.305" Thick) 1.735"OD (1.040"ID) 1995-Up	1	
148235B	Race, ZF5HP24 (BMW) B Clutch Hub To C Clutch Hub (2.353"OD) (1.745"ID) 1995-Up	1	
148236B	Bearing W/Race, ZF5HP24 (BMW) B Clutch Hub To C Clutch Hub (.257" Thick) 2.330"OD (1.560"ID) 1995-Up	1	
148236BK	Bearing Set, ZF5HP24/ZF5HP24A B Clutch Hub To C Clutch Hub (.257" Thick)(2.330"OD) (1.560"ID) 1995-Up (Contains: # 236 & 235)	1	
148238B	Bearing W/Races, ZF5HP24/ZF5HP24A Forward Sun Gear To Overdrive Planet (.200" Thick) 2.455"OD (1.645"ID) 1995-Up	1	
148243B	Bearing W/Race, ZF5HP24/ZF5HP24A D & E Clutch Drum To Forward Planet (.260" Thick) 2.520"OD (1.820"ID) 1995-Up	1	
148243BK	Bearing Set, ZF5HP24/ZF5HP24A D & E Clutch Drum To Forward Planet (Contains: # 243B & 244B) 1995-Up	1	
148244B	Race, ZF5HP24/ZF5HP24A D & E Clutch To Forward Planet (.078" Thick) 2.836"OD (1.655"ID) 1995-Up	1	
148267BA	Shim, ZF5HP24 (BMW) Park Gear To Yoke (Selective) (1.591"OD) 1995-Up	1	
148270BK	Ball Bearing Assembly, ZF5HP24 (BMW) Ball Bearing With Inner & Outer Races (16 Balls) 1.300" Thick Race (Cast # SKF BA2B Italy-A 636002 AA) 1995-Up	1	
148295B	Caged Needle Bearing, ZF5HP24 (BMW) Pump Body (2.045"OD) 1995-Up (Cast # INA F-216974 Germany 6136)	1	

PART #	GASKETS & RUBBER COMPONENTS	QTY	REFERENCE #
148300A	Gasket, ZF5HP24 AWD 1995-Up	1	
148300B	Gasket, ZF5HP24 2WD 1995-00	1	
148310B	Gasket, ZF5HP24 (BMW) Pump Cover To Case 1995-Up	1	
148311B	Use 141311A	1	
141311A	O-Ring, ZF5HP24 (BMW) Pump Body 1995-Up	1	
148348B	O-Ring, ZF5HP24 (BMW) Extension Housing 1995-Up	1	
148386B	Use 141386A	2	
141386A	Seal, ZF5HP24 (BMW) D & E Clutch To Case) 1995-Up	2	

PART #	TECHNICAL MANUALS	QTY	REFERENCE #
185400A	Repair Manual, ZF5HP24 FWD/AWD (Audi/Volkswagen)	1	
128400A-1	Valve Body Manual, ZF5HP24	1	
148400B	Repair Manual, ZF5HP24 RWD (BMW/Jaguar/Land Rover)	1	
148400BFD	Manual, ZF5HP24/ZF5HP24A Functional Description 1994-Up	1	

PART #	ELECTRICAL COMPONENTS	QTY	REFERENCE #
148410B	Switch, ZF5HP24 (BMW) Neutral Safety (Cast # 0501 211 451) With 5 Prong Round Connector On A Wire Harness) 1995-Up	1	
148420A	Solenoid Kit, ZF5HP24/ZF5HP24A (For ZF5HP24 Units Ending In 021/022/026/027/028/029/032/034)(For All ZF5HP24A Units) 1994-Up	1	
141420B	Solenoid Kit, ZF5HP24A (For Units Ending In 005/009/013/014/015/016/024) (Contains: 3 Shift, 4 EPC Solenoids With O-Rings)	1	
138436A	Sensor, ZF5HP24 (All) Input Speed	1	
148436A	Sensor, ZF5HP24A (Audi) Output Speed (Located In The Speed-O Cover) 1995-Up	1	
148436B	Sensor, ZF5HP24 (BMW) Input & Output Speed (Goes Through The Valve Body)(Takes 2) (Plugs Into Wire Harness # 446) 1995-Up	2	
148446A	Wire Harness, ZF5HP24A (Audi/VW Audi) Internal 1994-Up	1	
148446B	Wire Harness, ZF5HP24 (BMW) Internal With 16 Prong Case Connector (With 8 Two Blade Connectors And 2 Speed Sensors) 1995-Up	1	

PART #	MISCELLANEOUS COMPONENTS	QTY	REFERENCE #
148490B	Vent, ZF5HP24 (BMW) Plastic In Pump Cover 1995-Up	1	
148459B	Retainer, ZF5HP24 (BMW) Holds Solenoids To Valve Body 1995-Up	1	
PART #	HARD PARTS	QTY	REFERENCE #
148510A	Pump Body W/Gears, ZF5HP24 (Cast # 105 841 00 75) Inner Gear Is .550" Thick With 14 Teeth	1	
148510B	Pump Body W/Gears, ZF5HP24 (BMW) (Cast # 1058410078) 14 Teeth Inner Gear (.551" Thick) 1995-Up	1	
148520B	Pump Cover, ZF5HP24 (BMW) Aluminum (2.165" Thick At Edge) 1995-Up	1	
148529B	Stator Tube, ZF5HP24 (BMW) 5 1/2" Long (3.422"OD Flange) .923"ID At Splines (1 Rear Bushing) 1995-Up	1	
PART #	PUMP COMPONENTS	QTY	REFERENCE #
148530B	Pump Gear Set, ZF5HP24 (BMW) 14 Teeth Inner Gear (.551" Thick) 1995-Up	1	
PART #	HARD PARTS (Continued)	QTY	REFERENCE #
148544A	Pump Plate, ZF5HP24A (Audi) 1994-Up	1	
148544B	Pump Plate, ZF5HP24 (BMW) (.118" Thick)(6 11/16"OD) 1994-Up	1	
148550B	Drum, ZF5HP24 (BMW) C Clutch (Aluminum) 24 Teeth Steels (Cast # 105847201) 1995-Up	1	
148551B	Drum, ZF5HP24/ZF5HP24A (F Clutch)(Aluminum) 6 Clutch (2.851" Thick) 6 3/8"OD 1994-Up	1	
148554B	Drum, ZF5HP24 (BMW) A Clutch With 7 1/4" Long Shaft (27 Splines) 6 Clutch (Uses 24 Teeth Steels) 1995-Up	1	
148556B	Drum, ZF5HP24 (BMW) B Clutch (6 Clutch) Stamped Steel (30 Teeth Steels) 7 1/2"OD (3.550" Tall) 2.040"ID Bore 1995-Up	1	
148558B	Drum, ZF5HP24 (BMW) D & E Clutch (Aluminum) 4.58" Wide (7 5/8"OD) (Cast # 1058 473 037) 1995-Up	1	
148560B	Piston Kit, ZF5HP24 (BMW) C Clutch (Aluminum Piston) Cast # 1058 472 020 1995-Up	1	
148561B	Piston Kit, ZF5HP24 (BMW) F Clutch (Bonded Piston) 1995-Up	1	
148562B	Piston Kit, ZF5HP24 (BMW) E Clutch (Steel Piston) 1995-Up	1	
148564B	Piston Kit, ZF5HP24 (BMW) A Clutch (Aluminum Piston) (With Cast # 1058470 059) 1995-Up	1	
148565B	Piston Kit, ZF5HP24 (BMW) D Clutch	1	
148566B	Piston Kit, ZF5HP24 (BMW) B Clutch (Cast # 1058471 039 A On Piston) 1995-Up	1	
148570B	Hub, ZF5HP24 (BMW) C Clutch (30 Outer Lugs) 40 Teeth Clutch Hub 1995-Up	1	
148571B	Hub, ZF5HP24 (BMW) F Clutch (1st Gear Freewheel Outer Race) 24 Outer Lugs (30 Clutch Splines) 2.075" Thick (3.495"ID) 1995-Up	1	
148576B	Hub, ZF5HP24/ZF5HP24A B Clutch (30 Clutch Splines) With 2.600"OD Hub On Rear For Bushing #046 1995-Up	1	
148580B	Planet, ZF5HP24 (BMW) Overdrive With Shaft (4 Gear Steel) 24 Outer Lugs (Uses A 32 Teeth Sun Gear #614)(32 Teeth Pinions, 2 Grooves) 1995-Up	1	
148582B	Planet, ZF5HP24 (BMW) Forward (3 Gear Steel) 20 Outer Lugs (Uses A 36 Teeth Sun Gear) (29 Teeth Pinions, 1 Groove) 1995-Up	1	
148584B	Planet, ZF5HP24 (BMW) Output With Shaft (7 13/16" Long) 5 Gear (28 Teeth Pinions With 3 Grooves) 1995-Up	1	
148590B	Ring Gear, ZF5HP24 (BMW) Overdrive Planet (100 Teeth) 20 Lugs (1.350" Thick) 1995-Up	1	
148592B	Ring Gear, ZF5HP24 (BMW) Forward Planet With Shell (Stamped Steel) 4.070" Tall (93 Teeth Ring Gear) 1995-Up	1	
148594B	Ring Gear, ZF5HP24 (BMW) Output Planet (90 Teeth) 24 Outer Lugs (.878" Thick) 1995-Up	1	
148612B	Sun Gear, ZF5HP24 (BMW) Forward Planet (36 Teeth, 1 Groove) .750" Thick (2.332"OD) 1995-Up	1	
148614B	Sun Gear, ZF5HP24 (BMW) Overdrive/Output Planet (32 Teeth/35 Teeth) 1.646" Long (Splined ID) 1995-Up	1	
148639B	Key Way, ZF5HP24 (BMW) Holds D & E Clutch Drum To Case (.240" Thick) .472" Wide (1.170" Long) 1995-Up	2	
148642B	Hub, ZF5HP24 (BMW) E Clutch (Aluminum) 30 Clutch Splines (1.260" Thick) (2.688"ID) 1995-Up	1	
PART #	SPRAGS & ONE WAY CLUTCHES	QTY	REFERENCE #
128650A	Freewheel, ZF5HP24 (BMW) 1st Gear Freewheel (30 Elements)(1/2 Plastic & 1/2 Metal Cage) 1995-Up	1	
148650B	Use 128650A	1	
148660B	Inner Race, ZF5HP24 (BMW) 1st Gear Freewheel (1.250" Thick) 2.845"OD (Splined ID) 1995-Up	1	

ZF

PART #	HARD PARTS (Continued)	QTY	REFERENCE #
148672B	Shaft, ZF5HP24 (BMW) Sun Gear (4.530" Long, Splined Ends) 1995-Up	1	
148674B	Hub With Shaft, ZF5HP24 (BMW) A Clutch (10 3/8" Long) (40 Teeth Hub) 1995-Up	1	
148690B	Park Gear, ZF5HP24 (BMW) 20 Lugs (36 Teeth Reluctor) 1995-Up	1	
148694B	Retainer, ZF5HP24 (BMW) 1st Gear Freewheel (3.777"OD)(2.287"ID) 1995-Up	1	
148697BB	Sleeve, ZF5HP24 (BMW) D & E Clutch Drum (.435" Thick) 2.157"OD (1.446"ID) Has 2 O-Rings & 2 Holes (Steel) 1995-Up	1	
148699B	Spacer, ZF5HP24 (BMW) Front Seal To Caged Needle Bearing 1995-Up (.076" Thick) 2.040"OD (1.610"ID) With 10 Humps	1	
148699BB	Oil Deflector, ZF5HP24 (BMW) Caged Needle Bearing To Pump Body (Plastic) (1.545"ID) 1995-Up	1	
148740B	Valve Body, ZF5HP24 (BMW) With 8 Solenoids On One End & Speed Sensor (Cast # 1058 427 022)(5 Black & 3 Blue Solenoids) 1995-Up	1	
148740BB	Valve Body, ZF5HP24 (With 7 Solenoids & Speed Sensor)(Cast # 1060 427 013 F2) (4 Black & 3 Blue Solenoids) 1997-Up	1	
148740BC	Valve Body, ZF5HP24 (With 7 Solenoids & Speed Sensor)(Cast # 1060 427 135 F4) (4 Black & 3 Brown Solenoids) 2004-Up	1	
148740C	Valve Body, ZF5HP24 (Jaguar) With 8 Solenoids On One End & Speed Sensor (Cast # 1058 427 022)(4 Black, 3 Brown & 1 Green Solenoid) 1995-Up	1	

PART #	VALVE BODY COMPONENTS	QTY	REFERENCE #
148741G	Accumulator Piston, ZF5HP24 Forward & Reverse Clutch (Updated) (In The Valve Body) This Is The A Clutch & C Clutch Accumulator (Takes 2 Per Transmission) 1994-Up	2	

PART #	HARD PARTS (Continued)	QTY	REFERENCE #
148748B	Spring, ZF5HP24 (BMW) Holds D & E Clutch Seal In Case (.435"OD) 1.680" Long 1995-Up	2	
148750B	Bell Housing, ZF5HP24 (BMW) 7 3/4" Top Bolts (Sensor At 7:00) Cast # 1058-442-911 (Starter At 9:00 & 3:00) 1995-Up	1	
148750C	Bell Housing, ZF5HP24 (Jaguar) Cast # 1058-422-009	1	
148760B	Case, ZF5HP24 (BMW) (16 5/8" Long) 1995-Up	1	
148760C	Case, ZF5HP24 (Jaguar) (Cast # 1058401083)	1	
148765B	Pan, ZF5HP24 (BMW) Bottom (22 Bolt, With Drain Plug) 1995-Up	1	
148770B	Extension Housing, ZF5HP24 (BMW) Aluminum (Cast # 1058 414 007) 10 Bolt (2.870"OD Rear Seal) 1995-Up	1	
148776BK	Bolt Set, ZF5HP24 (BMW) Bell Housing To Case (20 Pieces) 1995-Up	1	
148778BBK	Bolt Set, ZF5HP24 (BMW) Pump Cover To Tube (5 Pieces) 1995-Up	1	
148778BK	Bolt Set, ZF5HP24 (BMW) Pump Cover To Body (10 Pieces) 1995-Up	1	
148779BK	Bolt Set, ZF5HP24 (BMW) Pan To Case (22 Pieces) 1995-Up	1	
148780BK	Bolt Set, ZF5HP24 (BMW) Extension Housing To Case (10 Pieces) 1995-Up	1	
148782BK	Bolt Set, ZF5HP24 (BMW) Valve Body To Case (22 Pieces) 1995-Up	1	
148790BK	Bolt Set, ZF5HP24 (BMW/Jaguar) F Clutch Drum To Case (12 Pieces) 1995-Up	1	
148798B	Nut, ZF5HP24 (BMW) Holds Yoke To Output Planet (6 Square Notches) 1995-Up	1	
148841B	Yoke, ZF5HP24 (BMW) Output Shaft (5.920" Long) (.554"OD Pilot) 1995-Up	1	
148843B	Clip, ZF5HP24 (BMW) Holds Case Connector To Case 1995-Up	1	
148861BA	Snap Ring, ZF5HP24 (BMW) Holds C Clutch Pressure Plate In (Selective) 1995-Up	1	
148863B	Snap Ring, ZF5HP24 (BMW) Holds Bearing #219 In Drum (.468" Thick) (1.738"OD) 1995-Up	1	
148864BA	Snap Ring, ZF5HP24 (BMW) Holds F Clutch Pressure Plate In (Selective) 1995-Up	1	
148865B	Snap Ring, ZF5HP24 (BMW) Holds #571 Hub To F Clutch Drum (.042" Thick) (2.353"OD) 1995-Up	1	
148866B	Snap Ring, ZF5HP24 (BMW) Holds 1st Gear Freewheel To #571 Hub (.077" Thick) (3.985"OD) 1995-Up	1	
148868B	Use 148889B	1	
148873BA	Use 148892	1	
148876BA	Snap Ring, ZF5HP24 (BMW) Holds A Clutch Pressure Plate In (Selective) 1995-Up	1	
148877B	Snap Ring, ZF5HP24 (BMW) Holds A Clutch Retainer In (.097" Thick) (1.630"OD) 1995-Up	1	
148878BA	Use 148892	1	
148882B	Snap Ring, ZF5HP24 (BMW) Holds Overdrive Ring Gear To Forward Planet (.060" Thick) (6 1/16"OD) 1995-Up	1	
148883B	Snap Ring, ZF5HP24 (BMW) Holds D & E Clutch Drum In Case (.109" Thick) 8"OD (Beveled) 1995-Up	1	
148885B	Snap Ring, ZF5HP24 (BMW) Holds Hub # 570 To B Clutch Drum (.101" Thick) (7 7/16"OD) 1995-Up	1	
148889B	Snap Ring, ZF5HP24 (BMW) Holds Overdrive Planet Ring Gear To Forward Planet Ring Gear Shell (.077" Thick) (6 5/8"OD) 1995-Up (Also Fits ZF5HP24 (BMW) Snap Ring # 868 1995-Up)	1-2	

148892BA.....	Snap ring, ZF5HP24 (BMW) Holds B Clutch Pressure Plate In (Selective) 1995-Up	
.....	(Also Fits ZF5HP24 (BMW) D Clutch #878 1995-Up) (Also Fits ZF5HP24 (BMW) E Clutch #873	
.....	1995-Up)	1-3.....
148893B.....	Snap Ring, ZF5HP24 (BMW) Holds B clutch Retainer In Drum (.095" Thick) (3.381"OD)	
.....	1995-Up	1.....
148897B.....	Snap Ring, ZF5HP24 (BMW) Holds #270 Extension Housing (.120" Thick) 3.620"OD	
.....	(With 2 Eyelets) 1995-Up	1.....
148898B.....	Snap Ring, ZF5HP24 Holds Front Seal To Pump Body (.057" Thick) (2.155"OD) 1995-Up	1.....
148960B.....	Piston, ZF5HP24 (BMW) C Clutch (Aluminum) Cast # 1058 472 020 (.935" Thick) 4.837"OD	
.....	(2.370"ID) 1995-Up	1.....
148961B.....	Piston, ZF5HP24/ZF5HP24A (F Clutch) (Bonded) .980" Thick (5.578"OD) 2.315"ID	
.....	1995-Up	1.....
148962B.....	Piston, ZF5HP24 (BMW) E Clutch (Steel) .660" Thick (7"OD) 2.530"ID 1995-Up	1.....
148964B.....	Piston, ZF5HP24 (BMW) A Clutch (Aluminum) Cast # 1058470 059 (5.145"OD) (1.465"ID)	
.....	1995-Up	1.....
148965B.....	Piston, ZF5HP24 (BMW) D Clutch	1.....
148966B.....	Piston, ZF5HP24 (BMW) B Clutch (Aluminum) Cast # 1058471 039 A (1.615" Thick) 7"OD	
.....	(3.325"ID) 8 Oval Holes 1995-Up	1.....
148970B.....	Spring, ZF5HP24 (BMW) C Clutch Return (.055" Thick) 3.773"OD (12 Fingers) 1995-Up	1.....
148971B.....	Spring, ZF5HP24 (BMW) F Clutch Return (.080" Thick) 5.040"OD (12 Fingers) 1995-Up	1.....
148972B.....	Spring, ZF5HP24 (BMW) E Clutch Return (.069" Thick) 5.290"OD (12 Fingers) 1995-Up	1.....
148974B.....	Spring, ZF5HP24 (BMW) A Clutch Return (.060" Thick) 3.570"OD (10 Fingers) 1995-Up	1.....
148975B.....	Spring, ZF5HP24 (BMW) D Clutch Return (.055" Thick) 6 5/8"OD (20 Fingers) 1995-Up	1.....
148976B.....	Spring, ZF5HP24 (BMW) B Clutch Return (.057" Thick) 4.823"OD (16 Fingers) 1995-Up	1.....
148980B.....	Retainer, ZF5HP24 (BMW) C Clutch Return Spring (C Clip) 1995-Up (2 Per Pack)	
.....	(Also Fits ZF5HP24 (BMW) F Clutch #981 1995-Up)	1-2.....
148981B.....	Use 148980B	1.....
148982B.....	Retainer, ZF5HP24 (BMW) E Clutch Return Spring (C Clip) 1995-Up (2 Per Pack)	1.....
148984B.....	Retainer, ZF5HP24 (BMW) A Clutch Spring (Steel) 4.780"OD (1.400"ID) 1995-Up	1.....
148985B.....	Snap Ring, ZF5HP24 (BMW) Holds D Clutch Spring Retainer In (.095" Thick) 5.600"OD	
.....	(Stepped) 1995-Up	1.....
148986B.....	Retainer, ZF5HP24 (BMW) B Clutch Return Spring (.086" Thick) 3.742"OD (3.273"ID)	
.....	Stepped 1995-Up	1.....
148991B.....	Linkage, ZF5HP24 (BMW) Internal (5 Pieces) 1995-Up	1.....
148995B.....	Park Pawl Assembly, ZF5HP24 (BMW) (4 Pieces) 1995-Up	1.....
148999B.....	Oil Tube Set, ZF5HP24 (BMW) (3 Pieces) 1995-Up	1.....

ZF