



**XJ-S**  
**MODEL YEAR**

**U P D A T E**

**1989**

**SUPPLEMENT**





**JAGUAR**

**XJ-S**

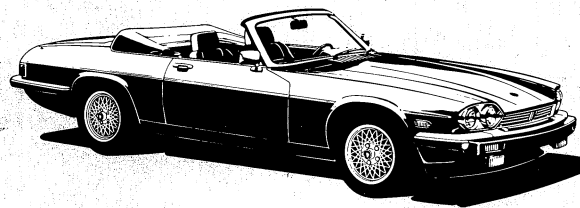
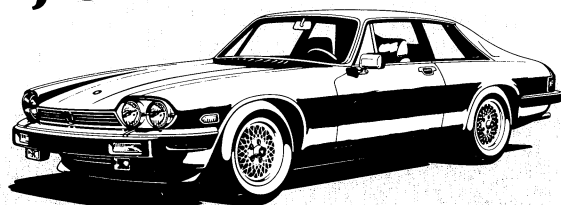

**1989**

## **SUPPLEMENT**

Publication number S-60/SUPP

©1988 Jaguar Cars Inc.

All rights reserved. All material contained herein is based on the latest information available at the time of publication. The right is reserved to make changes at any time without notice.

# CONTENTS

<b>INTRODUCTION</b>	1
<b>FEATURES</b>	2
<b>DIGITAL IGNITION SYSTEM</b>	4-13
SYSTEM DESCRIPTION	4-5
OPERATION	6-7
COMPONENTS	8-12
SERVICE AND TESTING	13
<b>EFI AND EMISSIONS CONTROL</b>	14-15
<b>WIRING HARNESS AND FUSES</b>	16-18

# INTRODUCTION

The 1989 XJ-S has undergone mid-year changes to the engine management system, tachometer, and certain electrical systems. An earlier change to the EFI system is also described in this publication. Please note that the mid-year changes start at different Vehicle Identification Numbers for the coupe and convertible.

MID-YEAR CHANGES (COUPE)	VIN 157118-ON
MID-YEAR CHANGES (CONV.)	VIN 156989-ON
EFI AND EMISSIONS CHANGES	VIN 153560-ON

## Wiring color code

N	Brown	Y	Yellow
B	Black	O	Orange
W	White	S	Slate
K	Pink	L	Light
G	Green	U	Blue
R	Red	P	Purple

When a wire has two or more color code letters, the first letter indicates the main color and the subsequent letter(s) indicate the tracer color(s).

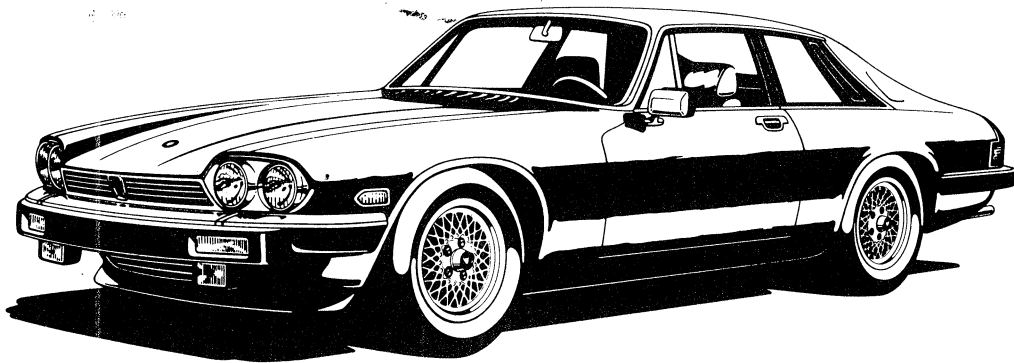
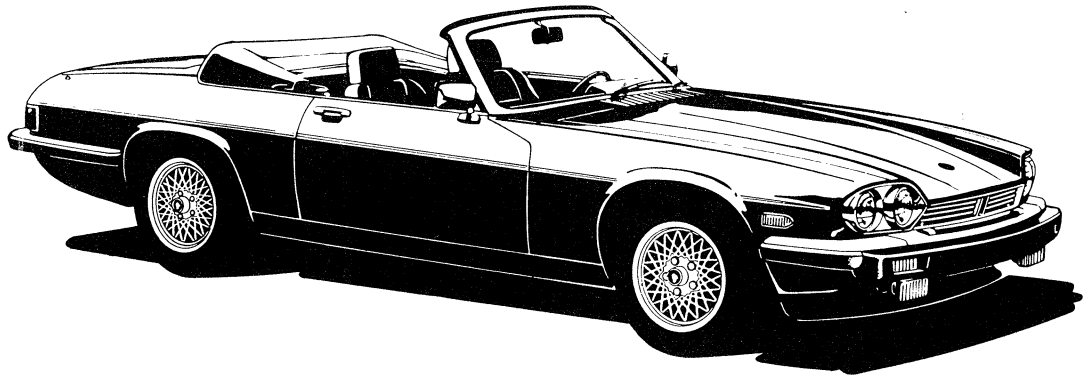

# FEATURES

## DIGITAL IGNITION SYSTEM

XJ-S models are now equipped with a digital microprocessor controlled ignition system manufactured by Marelli. This system provides precise ignition timing for all modes of engine operation from the ignition strategy stored in the microprocessor memory. To operate with this new system, the tachometer and the EFI ECU have been changed.

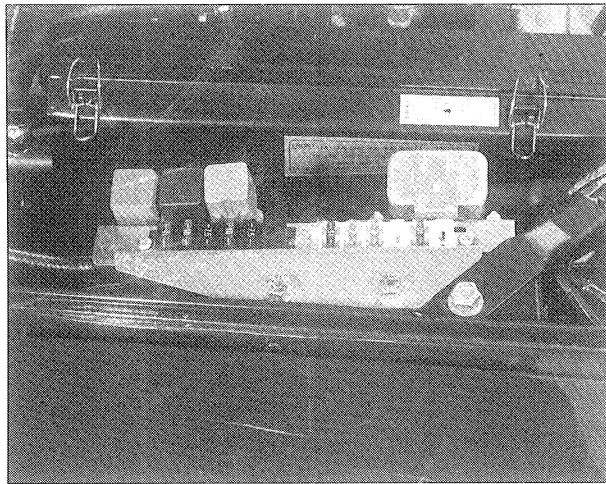
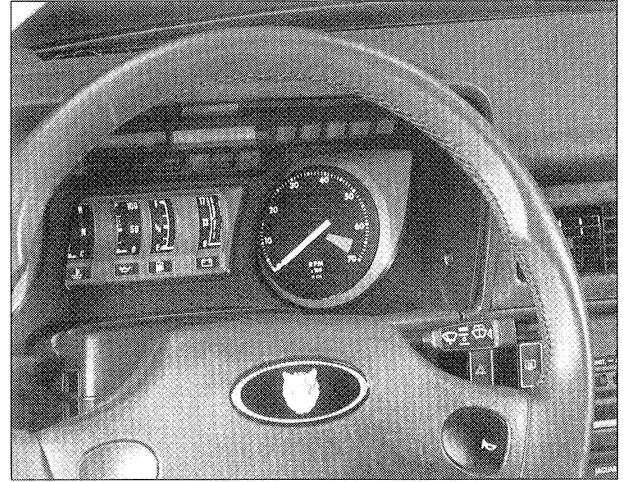
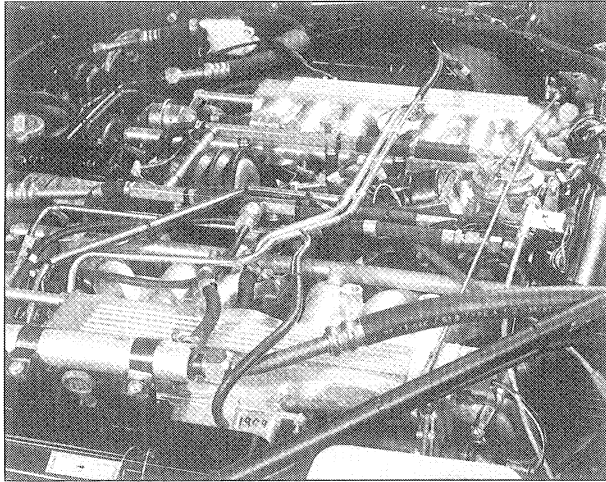

## WIRING HARNESS AND FUSES

Minor changes have occurred to several circuits including: cigar lighter, windshield wiper and washer, horns, cooling fan, power windows, and climate control. Updated wiring diagrams will be supplied with the 1989 MY XJ-S Electrical Guide.

## OVERVIEW

The new ignition system is a digital microprocessor controlled system that eliminates the vacuum and mechanical advance controls. The microprocessor memory contains an ignition timing strategy that has the precise timing for every engine speed and mode of operation. The microprocessor, in the ECU, receives input from engine sensors to program the necessary ignition timing. The double deck two rotor distributor distributes the high voltage to BANK A (right) via the lower deck and to BANK B (left) via the upper deck. The low voltage circuit is switched by the ECU via the two power modules to the two ignition coils. High voltage is generated by the ignition coils and supplied to the distributor.

The inputs supplied to the ECU from the engine sensors form two groups of control parameters: primary inputs and correction inputs. The crankshaft position and engine speed inputs are necessary for the engine to start. The remaining inputs effect engine operation but are not necessary for engine start.

### PRIMARY INPUTS:

CRANKSHAFT POSITION—TDC SENSOR

ENGINE SPEED—ENGINE SPEED (FLYWHEEL) SENSOR

ENGINE LOAD—MANIFOLD ABSOLUTE PRESSURE (MAP) SENSOR

### CORRECTION INPUTS:

THROTTLE POSITION—IDLE SWITCH

ENGINE COOLANT TEMPERATURE—COOLANT TEMPERATURE SENSOR

INTAKE AIR TEMPERATURE—AIR TEMPERATURE SWITCH



# DIGITAL IGNITION SYSTEM

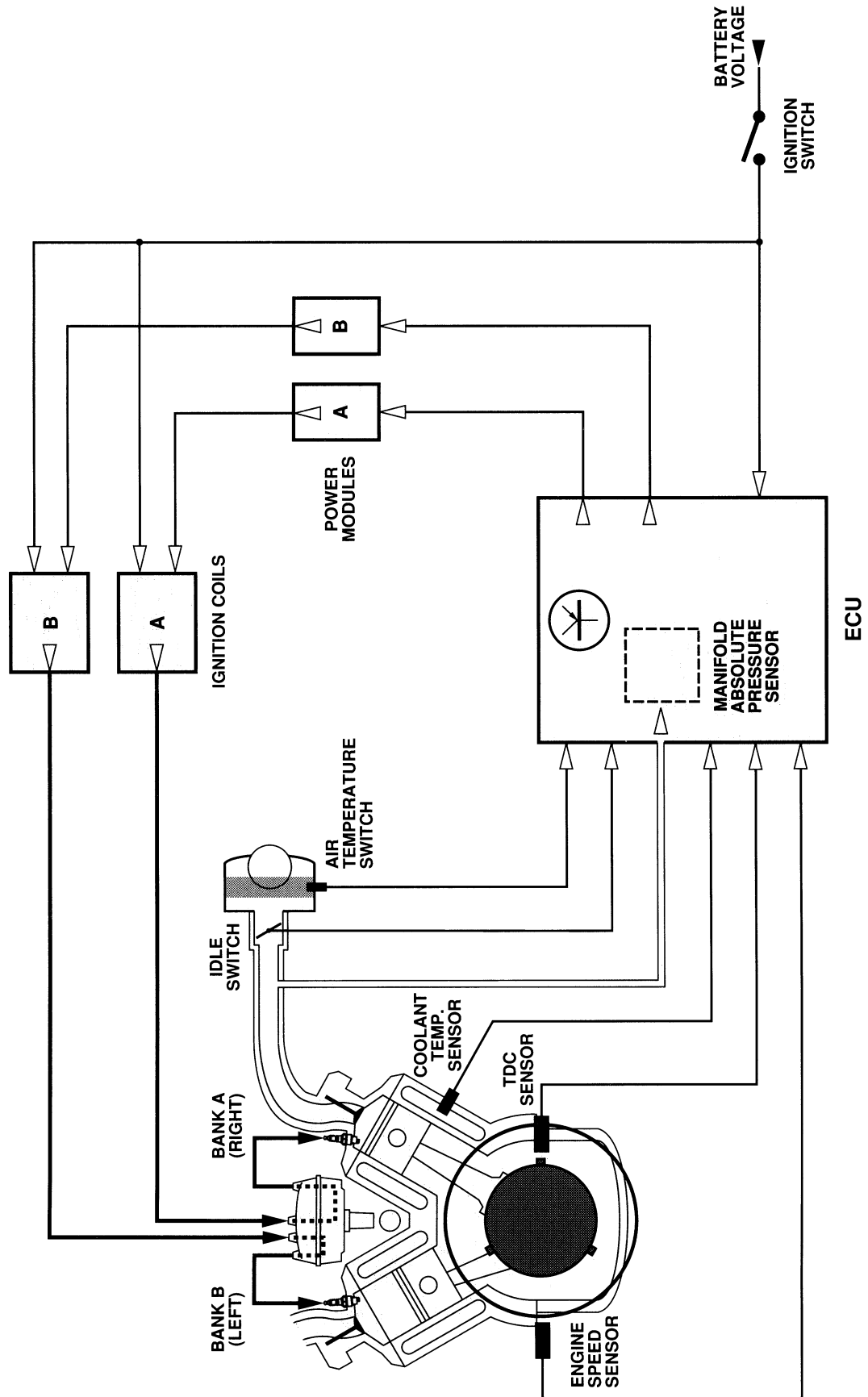

## ENGINE OPERATING MODES

### All operating modes

During all engine operating modes, the crankshaft position (TDC sensor) input is used by the ECU to program spark delivery. Crankshaft position is referenced from bank A. The ECU programs spark delivery for both banks from the bank A reference.

### Engine starting

Ignition timing during cranking and start-up is programmed by engine speed and coolant temperature. Engine speed is obtained from the engine speed (flywheel) sensor; engine coolant temperature is obtained from the coolant temperature sensor.

### Closed throttle running

Ignition timing during closed throttle operation is programmed separately for idle and deceleration. Closed throttle running is controlled by the idle switch and is programmed by engine speed and coolant temperature. When the idle switch is closed, the ECU does not recognize the engine load (manifold absolute pressure sensor) input and uses the idle portion of the ignition strategy for ignition timing. Engine speed is obtained from the engine speed (flywheel) sensor; engine coolant temperature is obtained from the coolant temperature sensor.

### Open throttle running

Ignition timing during open throttle running is programmed by primary inputs from engine speed and manifold pressure, and correction inputs from coolant temperature and intake air temperature. Engine speed is obtained from the engine speed (flywheel) sensor; engine load is obtained from the manifold absolute pressure (MAP) sensor; engine coolant temperature is obtained from the coolant temperature sensor; intake air temperature is obtained from the air temperature sensor.



# COMPONENTS

## ELECTRONIC CONTROL UNIT

**Location** Front passenger footwell, "A" post trim panel.

**Description** The ECU contains the micro-processor for receiving analog inputs from the engine sensors and programming the ignition timing which is accessed and delivered from the ignition strategy stored in the memory. Integral in the ECU is the manifold absolute pressure (MAP) sensor.

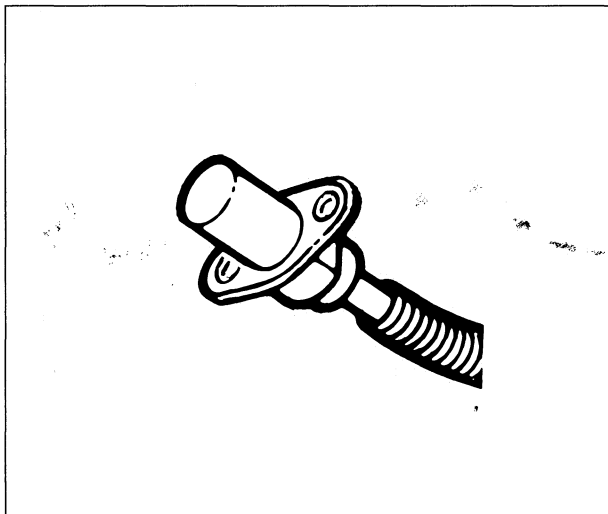
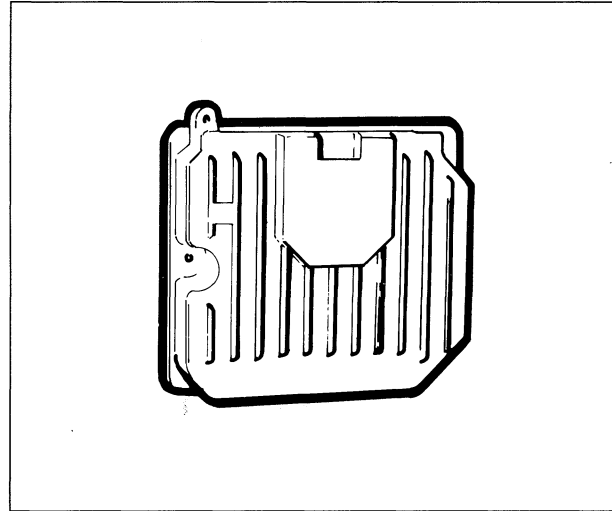

## TOP DEAD CENTER SENSOR

**Location** Front crankshaft pulley.

**Description** The sensor is triggered by a three toothed reluctor to produce a TDC reference for bank A.

## ENGINE SPEED SENSOR

**Location** Flywheel ring gear.

**Description** The sensor is triggered by the flywheel ring gear teeth which act as a reluctor to produce an engine speed signal.

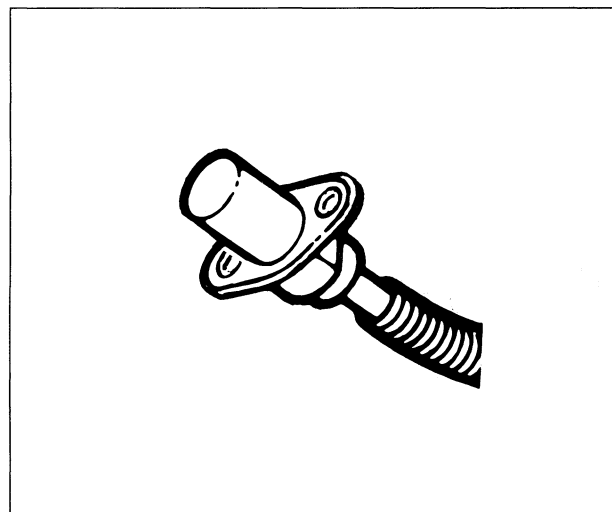

# DIGITAL IGNITION SYSTEM

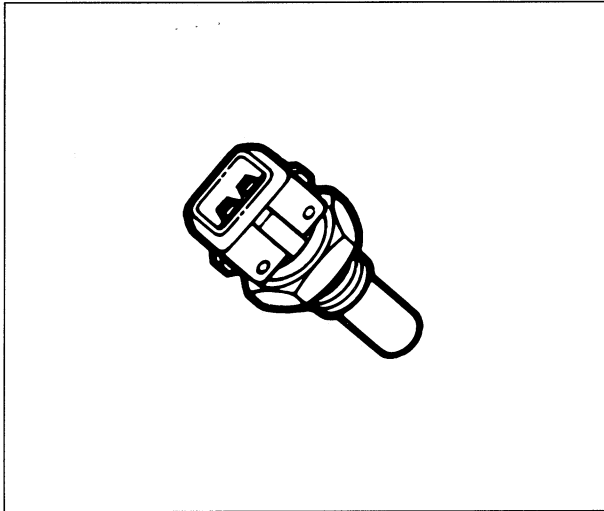

## COOLANT TEMPERATURE SENSOR

**Location** Bank A coolant rail.

**Description** The sensor produces a variable resistance dependent on temperature.

Temperature °C	Resistance Ohms
10	4.4k
20	2.5k
30	1.6k
40	1.2k
50	840
60	630
70	470
80	320
90	210

## IDLE SWITCH

**Location** Bank B throttle linkage bellcrank.

**Description** The micro switch is closed when the throttle is closed signaling the ECU that the engine is at idle or deceleration.

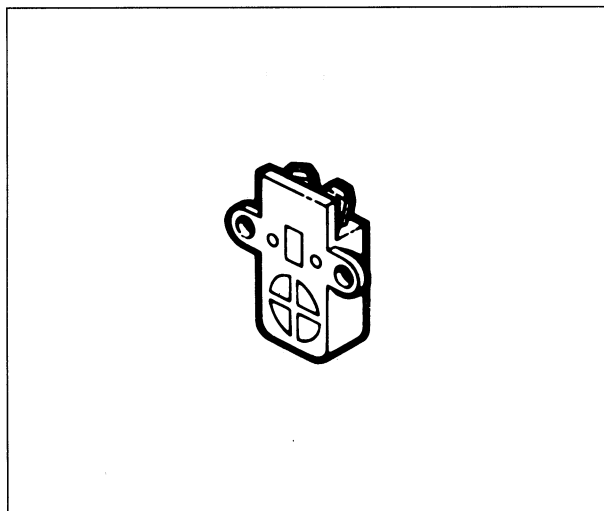
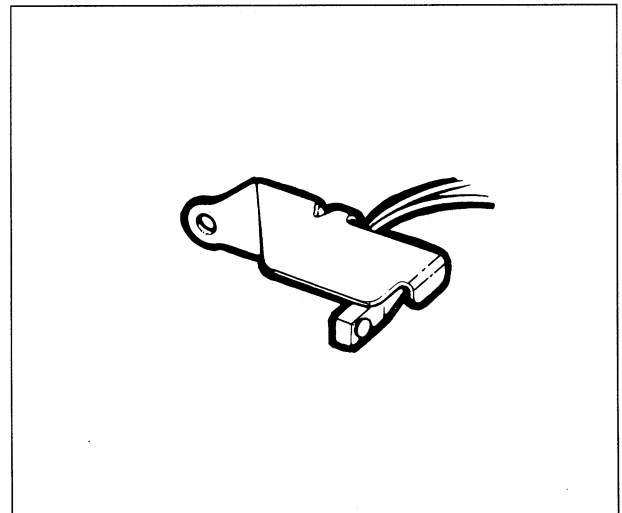

## AIR TEMPERATURE SWITCH

**Location** Bank A air cleaner back plate.

**Description** The bi-metal switch closes at 75°C to signal the ECU to retard the ignition timing at high intake air temperature.

# COMPONENTS

## POWER MODULES

**Location** Upper radiator support.

**Description** The power modules switch the low voltage coil circuit to ground when signaled by the ECU.

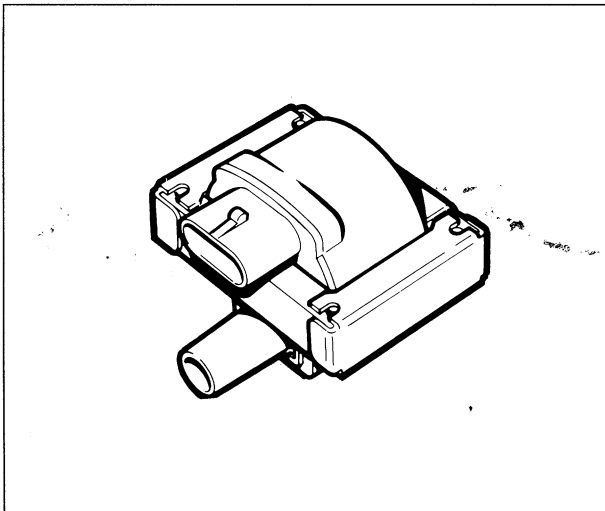
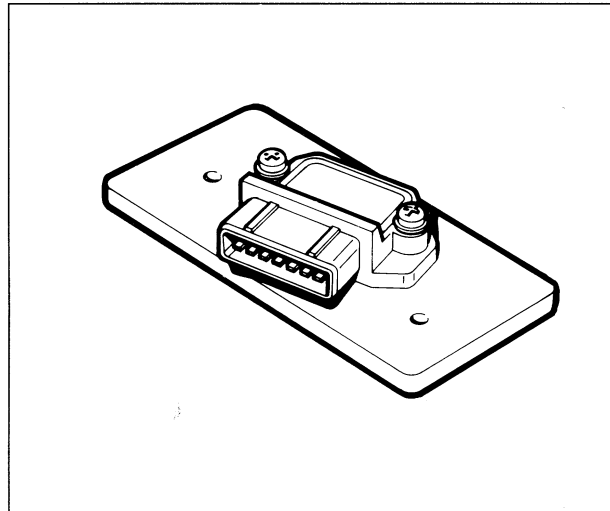

## IGNITION COILS

**Location** On the throttle turntable pedestal—bank A, lower (red ident on harness plug); bank B, upper (yellow ident on harness plug).

**Description** The ignition coils generate high voltage for distribution to the spark plugs.

## DISTRIBUTOR

**Location** Engine vee.

**Description** The distributor is a double deck design with the upper rotor distributing high voltage to bank B spark plugs, and the lower rotor distributing high voltage to bank A spark plugs.

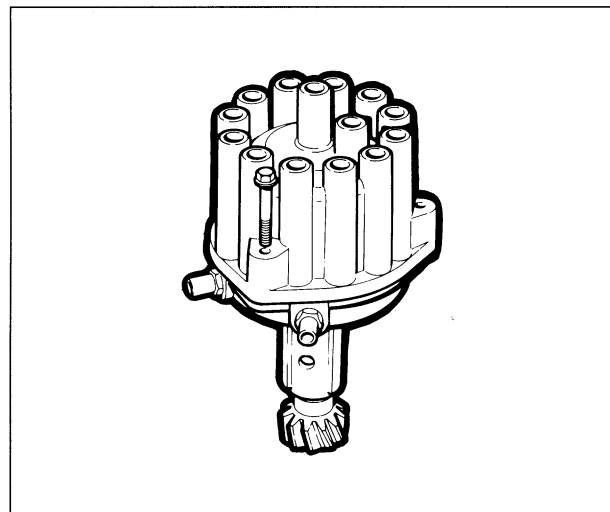

# DIGITAL IGNITION SYSTEM

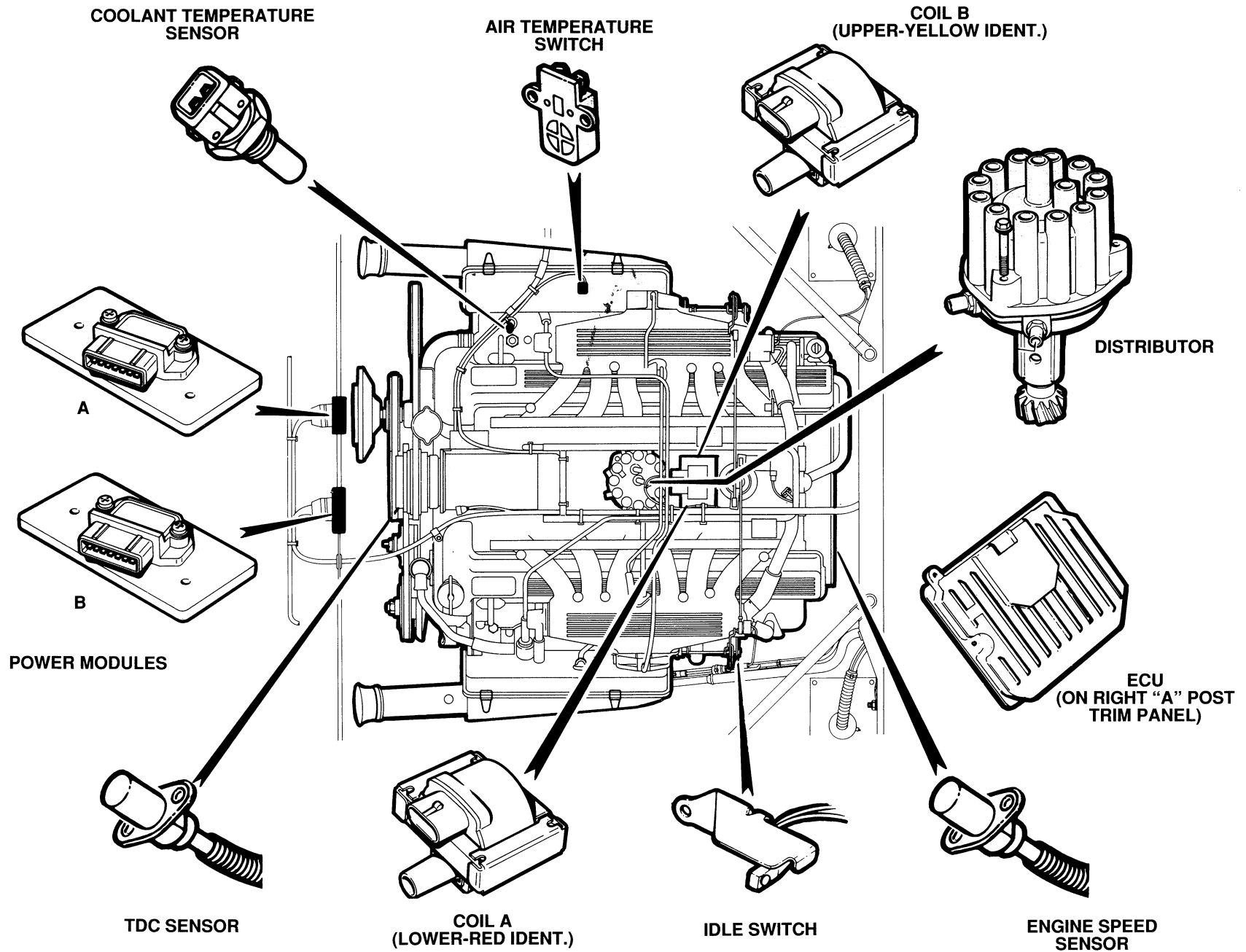

# COMPONENTS

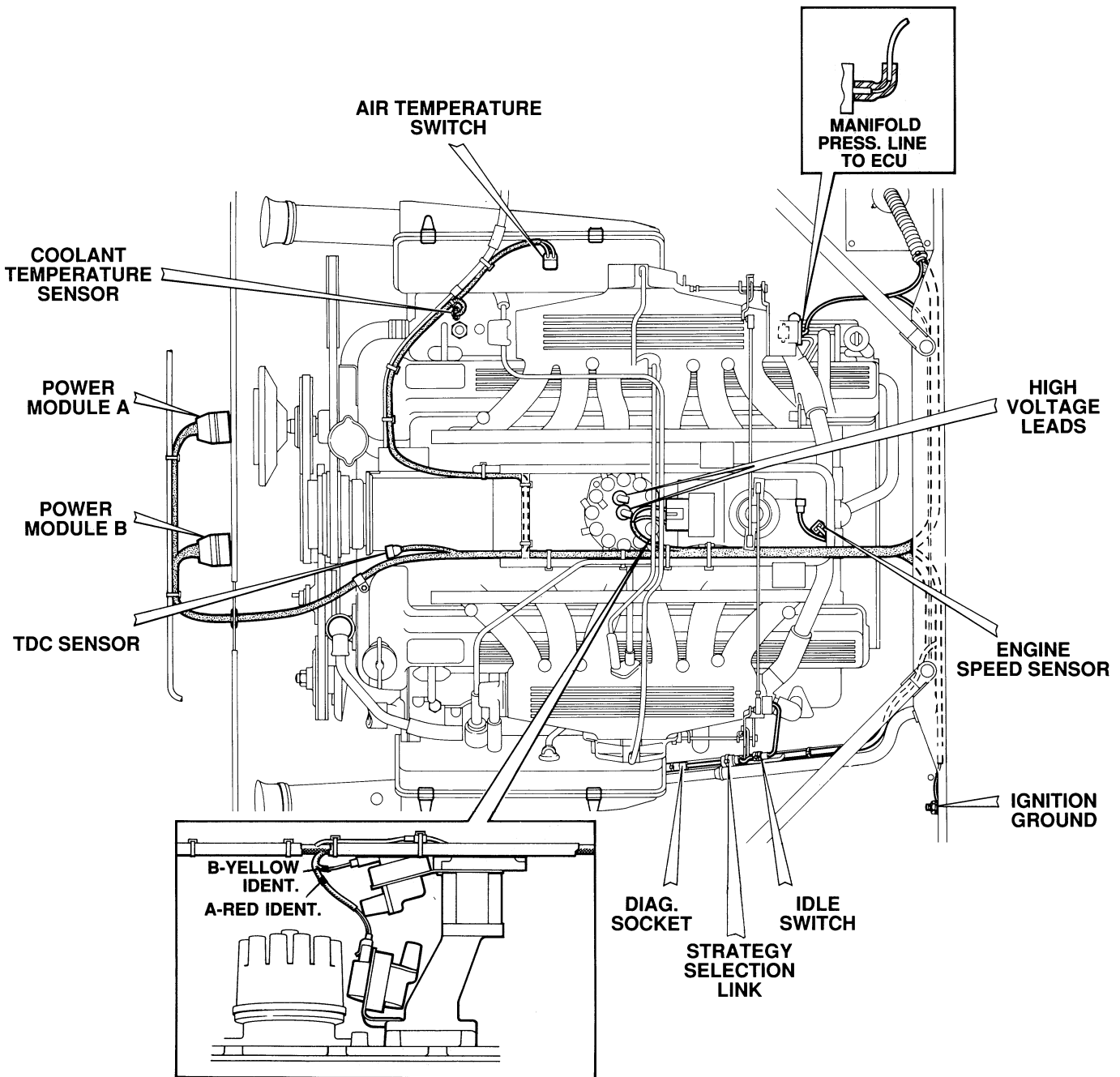

DIGITAL IGNITION HARNESS



# DIGITAL IGNITION SYSTEM

## SERVICE AND TESTING

### TDC and engine speed sensors air gap

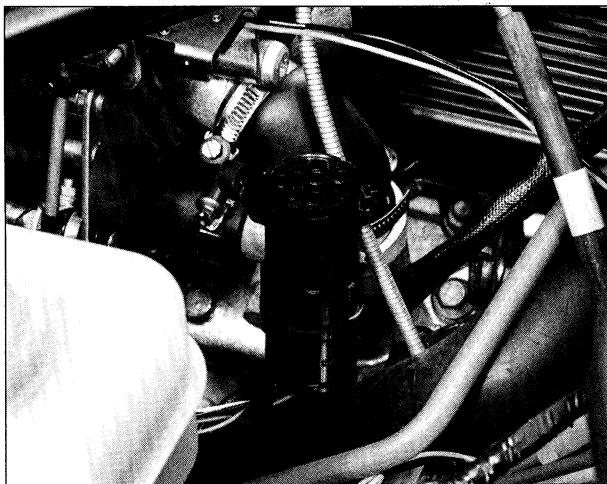
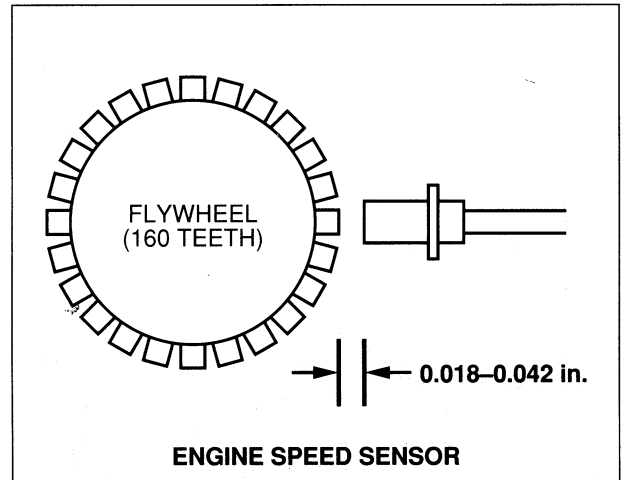
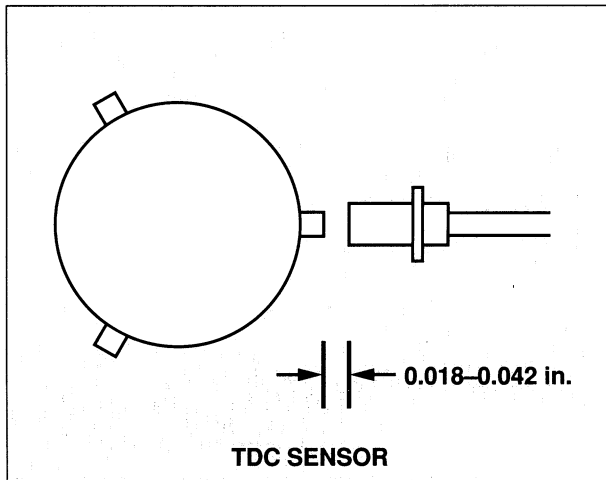

**Diagnostic socket** A diagnostic socket is provided in the ignition system harness. This connection and a connection at the ECU will be used in conjunction with a POD for JDS testing.

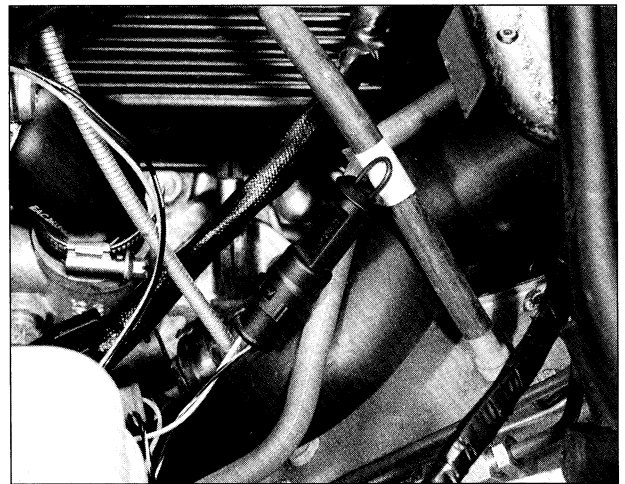

**Strategy selection link** The ECU memory contains two ignition strategies—one for high octane fuel and one for lower octane fuel. With the link installed, the high octane strategy is selected. With the link removed, the low octane strategy is selected. **The strategy selection link should remain installed and the vehicle operated on unleaded premium gasoline.**

# WIRING DIAGRAM

## EFI AND EMISSIONS CONTROL

**Feedback inhibit relay** Starting at VIN 153560, the feedback inhibit relay has been removed from the circuit. The wiring diagram on page 15 shows the revised wiring.

**EFI engine speed signal** With the change to the digital ignition system, the EFI ECU now receives the engine speed signal from the ignition ECU via the shielded white wire. The wiring diagram on page 15 shows the revised wiring.

**EFI Electronic Control Unit** With the change to the digital ignition system, the EFI ECU has been changed to enable it to receive the engine speed signal from the ignition ECU.

**Intake manifold deceleration valves** With the change to the digital ignition system, the intake manifold deceleration valves have been eliminated.

# EFI AND EMISSIONS CONTROL

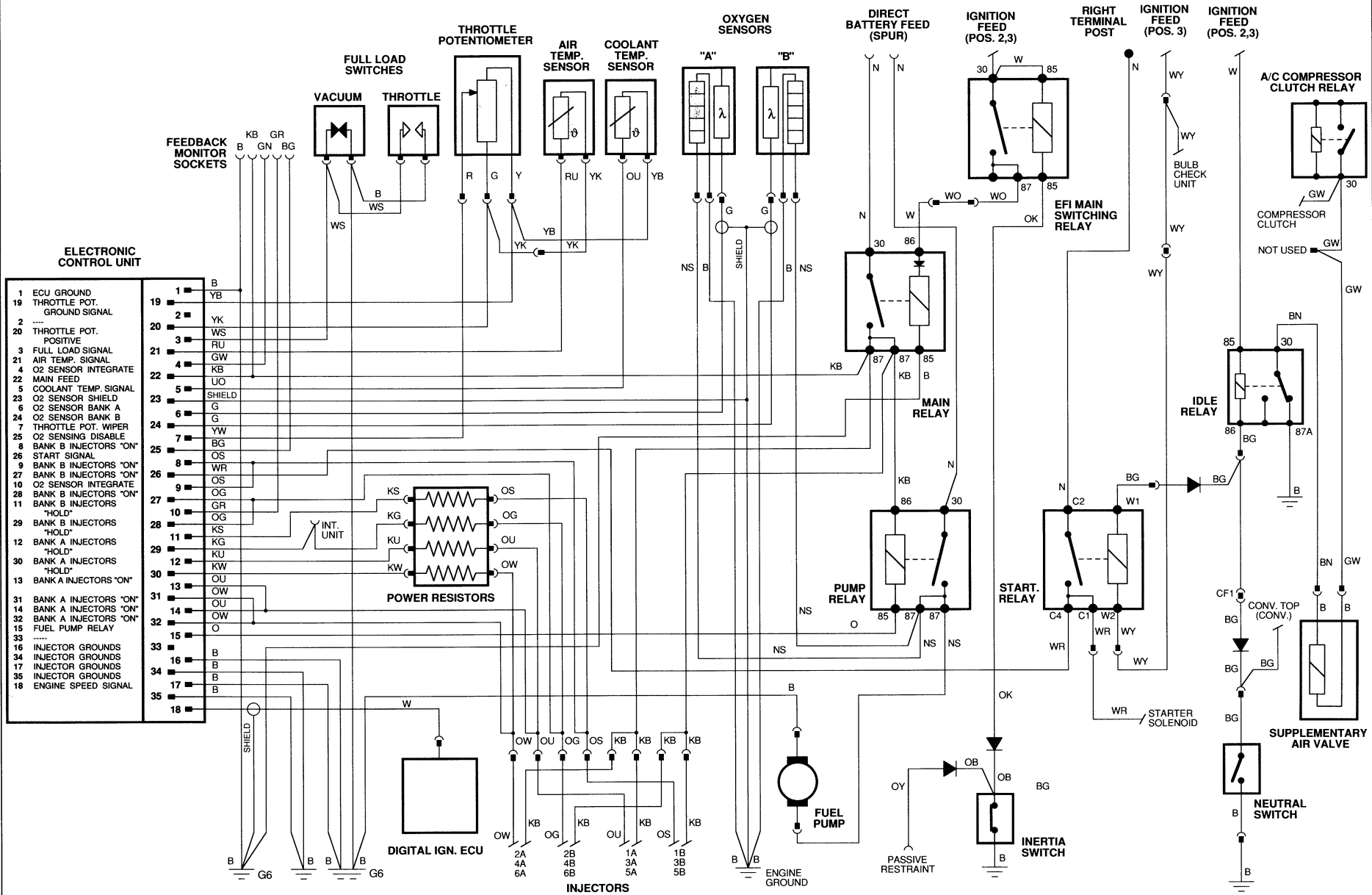

## MAIN FUSE PANEL

Number	Value	Color	Circuit(s)
1	10A	Red	Front fog lights
2	7.5A	Brown	Hazard warning, seat belt warning
3	15A	Lt. blue	Antenna, trunk lights
4	7.5A	Brown	Panel instruments, reverse lights
5	10A	Red	Turn signals, brake lights, transmission kickdown
6			Not used
7	5A	Tan	Panel, cigar lighter, selector lighting
8	7.5A	Brown	Door locks, power mirrors
9	15A	Lt. blue	Windshield wipers
10	25A	White	Blower motor—left
11	2A	Gray	Climate control controls
12	15A	Lt. blue	Heated rear window and door mirrors
13	10A	Red	Seat heater—right
14	5A	Tan	Seat lumbar adjustment—right
15	3A	Violet	Trip computer
16			Not used
17	15A	Lt. blue	Passive restraint—left
18	15A	Lt. blue	Passive restraint—right
19	10A	Red	Seat heater—left
20	5A	Tan	Seat lumbar adjustment—left

## AUXILIARY FUSE PANEL

Number	Value	Color	Circuit(s)
1	5A	Tan	Interior and map lights
2	2A	Gray	Side lights—left
3	2A	Gray	Side lights—right
4	10A	Red	Cigar lighter
5	25A	White	Blower motor—right
6	3A	Violet	Cruise control

# WIRING HARNESS AND FUSES

## ABS FUSE PANEL

Number	Value	Color	Circuit(s)
–	30A	Lt. green	ABS main
–	30A	Lt. green	ABS pump

## UNDER HOOD FUSE PANEL–BLACK

Number	Value	Color	Circuit(s)
1			Not used
2	7.5A	Brown	Low beam—right
3	10A	Red	High beam—right
4	7.5A	Brown	Low beam—left
5	10A	Red	High beam—left
6	15A	Lt. blue	Horns

## UNDER HOOD FUSE PANEL–WHITE

Number	Value	Color	Circuit(s)
1	15A	Lt. blue	Windshield washer
2	2A	Gray	Heated washer jets
3	2A	Gray	Cooling fan and horn control
4			Not used
5	10A	Red	Cooling fan
6			Not used

## CONVERTIBLE TOP FUSE PANEL

Number	Value	Color	Circuit(s)
–	30A	Lt. green	Convertible top motor

## IN-LINE FUSES

Circuit	Value	Location
Left tail light bulb failure	3A	Left rear inner fender
Right tail light bulb failure	3A	Right rear inner fender
Radio power	20A	Center console
Radio memory	2A	Center console
Antenna	10A	Right rear inner fender
A/C compressor clutch	10A	Right front inner fender

# FUSE PANELS

1	2	3	4	5	6	7	8	9	10
10A	7.5A	15A	7.5A	10A	NOT USED	5A	7.5A	15A	25A
2A	15A	10A	5A	3A	NOT USED	15A	15A	10A	5A
11	12	13	14	15	16	17	18	19	20

MAIN FUSE PANEL

3A	25A	10A	2A	2A	5A
6	5	4	3	2	1

AUXILIARY FUSE PANEL

BLACK

15A	10A	7.5A	10A	7.5A	NOT USED
6	5	4	3	2	1

WHITE

15A	2A	2A	NOT USED	10A	NOT USED
1	2	3	4	5	6

UNDERHOOD FUSE PANELS



**JAGUAR**

---

**XJ-S**  
**1989**



PRINTED IN USA  
JAGUAR CARS INC.

---