

JAGUAR S-TYPE

2003 Model Year Electrical Guide

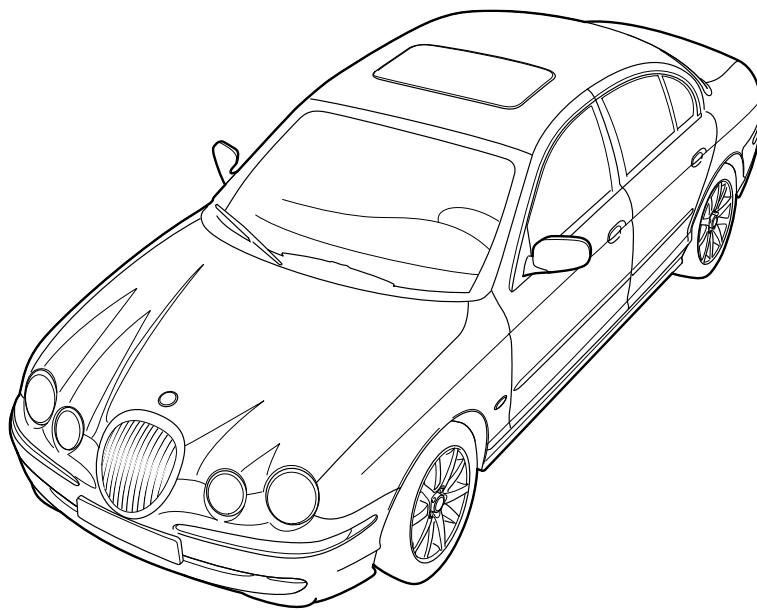

Publication number S2003STYPE

Date of Issue: June 2002

© 2002 Jaguar Cars

PRINTED IN USA

All rights reserved. All material contained herein is based on the latest information available at the time of publication. The right is reserved to make changes at any time without notice.



Table of Contents: Figures 2 – 3

Abbreviations and Acronyms 4

Introduction 5

Component Index 6 – 11

Symbols and Codes 12 – 14

Network Configuration 15

Fuse Box Location 16

Relay and Fuse Location 17

Harness In-Line Connectors 18 – 19

Control Module Location 20 – 21

Ground Point Location 22

Control Module Pin Identification 23 – 29

Electrical Guide Figures and Data follows after page 29
(pages are numbered by Figure number)

Appendix (SCP and CAN Messages) follows Figures and Data



FIGURES

Fig.	Description	Variant
01 Power Distribution		
Fig. 01.1	Main Power Distribution	All Vehicles
Fig. 01.2	Battery Power Distribution: Part 1	All Vehicles
Fig. 01.3	Battery Power Distribution: Part 2	All Vehicles
Fig. 01.4	Ignition Switched Power Distribution: I (Accessory)	All Vehicles
Fig. 01.5	Ignition Switched Power Distribution: II (Run)	All Vehicles
Fig. 01.6	Switched System Power Distribution	All Vehicles
Fig. 01.7	Engine Management System Switched Power Distribution	All Vehicles
02 Battery; Starter; Generator		
Fig. 02.1	Battery; Starter; Generator: V6	V6 Vehicles
Fig. 02.2	Battery; Starter; Generator: V8	V8 Vehicles
03 Engine Management		
Fig. 03.1	Engine Management: V6 – Part 1	V6 Vehicles
Fig. 03.2	Engine Management: V6 – Part 2	V6 Vehicles
Fig. 03.3	Engine Management: V8 N/A – Part 1	V8 N/A Vehicles
Fig. 03.4	Engine Management: V8 N/A – Part 2	V8 N/A Vehicles
Fig. 03.5	Engine Management: V8 SC – Part 1	V8 SC Vehicles
Fig. 03.6	Engine Management: V8 SC – Part 2	V8 SC Vehicles
04 Transmission		
Fig. 04.1	Transmissions	All Vehicles
05 Chassis		
Fig. 05.1	Dynamic Stability Control	All Vehicles
Fig. 05.2	Electronic Parking Brake; Variable Assist Power Steering	All Vehicles
Fig. 05.3	Adaptive Speed Control	Adaptive Speed Control Vehicles
Fig. 05.4	Suspension Adaptive Damping	Adaptive Damping Vehicles
06 Climate Control		
Fig. 06.1	Climate Control System; Windshield Heaters	All Vehicles
07 Instrumentation		
Fig. 07.1	Instrument Cluster; Audible Warnings	All Vehicles
08 Exterior Lighting		
Fig. 08.1	Exterior Lighting: Front	Non HID Headlamp Vehicles
Fig. 08.2	Exterior Lighting: Front – HID	HID Headlamp Vehicles
Fig. 08.3	Exterior Lighting: Rear	All Vehicles
Fig. 08.4	Exterior Lighting: Rear – Trailer Towing	Trailer Towing Vehicles
Fig. 08.5	Headlamp Leveling	Headlamp Leveling Vehicles
09 Interior Lighting		
Fig. 09.1	Interior Lighting	All Vehicles
Fig. 09.2	Dimmer-Controlled Lighting	All Vehicles
10 Steering Column; Pedals; Mirrors; Heaters		
Fig. 10.1	Steering Column Adjust; Pedal Adjust	All Vehicles
Fig. 10.2	Door Mirrors: Movement and Heaters; Heated Rear Window	All Vehicles
Fig. 10.3	Electrochromic Rear View Mirror; Fold-Back Mirrors	All Vehicles; Fold-Back Mirror Vehicles



FIGURES

Fig.	Description	Variant
11 Seat Systems		
Fig. 11.1 Driver Seat: 10-Way Movement with Memory	10-Way Driver Seat Memory Vehicles
Fig. 11.2 Driver Seat: 16-Way Movement with Memory	16-Way Driver Seat Memory Vehicles
Fig. 11.3 Driver Seat: Non Memory	Non Memory Driver Seat Vehicles
Fig. 11.4 Passenger Seat	6 / 8 / 10-Way Passenger Seat Vehicles
Fig. 11.5 Passenger Seat: 16-Way Movement	16-Way Passenger Seat Vehicles
Fig. 11.6 Seat Heaters	Heated Seat Vehicles
12 Central Locking; Security		
Fig. 12.1 Central Locking: Double Locking	Double Locking Vehicles
Fig. 12.2 Central Locking: Non Double Locking	Non Double Locking Vehicles
Fig. 12.3 Security System	All Vehicles
13 Wash / Wipe		
Fig. 13.1 Wash / Wipe System	All Vehicles
14 Powered Windows; Sliding Roof		
Fig. 14.1 Powered Windows; Sliding Roof	All Vehicles
15 In-Car Entertainment		
Fig. 15.1 In-Car Entertainment: Standard	Standard ICE Vehicles
Fig. 15.2 In-Car Entertainment: Premium	Premium ICE Vehicles
16 Telematics		
Fig. 16.1 Telephone System: ROW	ROW Vehicles
Fig. 16.2 Telephone System: NAS	NAS Vehicles
Fig. 16.3 Telephone System with Voice: ROW	ROW Vehicles
Fig. 16.4 Telephone System with Voice: NAS	NAS Vehicles
Fig. 16.5 Voice Control System	Voice Only Vehicles
Fig. 16.6 Navigation System (except Japan)	Navigation Vehicles (except Japan)
Fig. 16.7 Navigation System with TV (except Japan)	Navigation Vehicles with TV (except Japan)
Fig. 16.8 Navigation System: Japan	Japan Navigation Vehicles
17 Occupant Protection		
Fig. 17.1 Advanced Restraint System: Part 1	All Vehicles
Fig. 17.2 Advanced Restraint System: Part 2	All Vehicles
18 Driver Assist		
Fig. 18.1 Parking Aid System	Parking Aid Vehicles
19 Ancillaries		
Fig. 19.1 Ancillaries: Horn, Cigar Lighter, Power Point, Accessory Connector, Sun Shade, Garage Door Opener, Electronic Road Pricing	All Vehicles
20 Vehicle Multiplex Systems		
Fig. 20.1 Controller Area Network	All Vehicles
Fig. 20.2 Standard Corporate Protocol Network; Serial Data Link	All Vehicles
Fig. 20.3 D2B Network: Part 1	All Vehicles
Fig. 20.4 D2B Network: Part 2	All Vehicles
Fig. 20.5 D2B Network: Part 3	All Vehicles



The following abbreviations and acronyms are used throughout this Electrical Guide:

A/C	Air Conditioning
A/CCM	Air Conditioning Control Module
APP SENSOR	Accelerator Pedal Position Sensor
APP1	Accelerator Pedal Position Sensor Element 1
APP2	Accelerator Pedal Position Sensor Element 2
AUTO	Automatic Transmission
B+	Battery Voltage
BANK 1	RH Cylinder Bank (Cylinders 1, 3, 5, 7)
BANK 2	LH Cylinder Bank (Cylinders 2, 4, 6, 8)
CAN	Controller Area Network
CKP SENSOR	Crankshaft Position Sensor
CM	Control Module
CMP SENSOR / 1	Camshaft Position Sensor / RH Bank
CMP SENSOR / 2	Camshaft Position Sensor / LH Bank
D2B	D2B Network
DSC	Dynamic Stability Control
ECM	Engine Control Module
ECT SENSOR	Engine Coolant Temperature Sensor
EFT SENSOR	Engine Fuel Temperature Sensor
EGR	Exhaust Gas Recirculation
EGT SENSOR	Exhaust Gas Temperature Sensor
EOT SENSOR	Engine Oil Temperature Sensor
EVAP CANISTER CLOSE VALVE	Evaporative Emission Canister Close Valve
EVAP CANISTER PURGE VALVE	Evaporative Emission Canister Purge Valve
FTP SENSOR	Fuel Tank Pressure Sensor
GECM	General Electronic Control Module
GPS	Global Positioning System
HID	High Intensity Discharge
HO2 SENSOR 1 / 1	Heated Oxygen Sensor – RH Bank / Upstream
HO2 SENSOR 1 / 2	Heated Oxygen Sensor – RH Bank / Downstream
HO2 SENSOR 2 / 1	Heated Oxygen Sensor – LH Bank / Upstream
HO2 SENSOR 2 / 2	Heated Oxygen Sensor – LH Bank / Downstream
IAT SENSOR	Intake Air Temperature Sensor
IC	Instrument Cluster
ICE	In-Car Entertainment System
IMT VALVE / 1	Intake Manifold Tuning Valve / Top
IMT VALVE / 2	Intake Manifold Tuning Valve / Bottom
IP SENSOR	Injection Pressure Sensor
KS / 1	Knock Sensor / RH Bank
KS / 2	Knock Sensor / LH Bank
LH	Left Hand
LHD	Left Hand Drive
MAF SENSOR	Mass Air Flow Sensor
MAN	Manual Transmission
MAP SENSOR	Manifold Absolute Pressure Sensor
N/A	Normally Aspirated
NAS	North American Specification
PATS	Passive Anti-Theft System
PWM	Pulse Width Modulated
RECM	Rear Electronic Control Module
RH	Right Hand
RHD	Right Hand Drive
ROW	Rest of World
SCP	Standard Corporate Protocol Network
TCM	Transmission Control Module
TP SENSOR	Throttle Position Sensor
TP1	Throttle Position Sensor Element 1
TP2	Throttle Position Sensor Element 2
TURN	Turn Signal
TV	Television
V6	V6 Engine
V8	V8 Engine
VICS	Vehicle Information Control System
VVT VALVE / 1	Variable Valve Timing Valve / Bank 1
VVT VALVE / 2	Variable Valve Timing Valve / Bank 2
+ve	Positive
-ve	Negative



Electrical Guide Format

This Electrical Guide is made up of two major sections. The first section, at the front of the book, provides general information for and about the use of the book, and information and illustrations to aid in the understanding of the Jaguar S-TYPE electrical / electronic systems, as well as the location and identification of components.

The second section includes the Figures, which are the basis of the book. Each Figure is identified by a Figure Number (i.e. Fig. 01.1) and Title, and is accompanied by a page of data containing information specific to that Figure.

It is recommended that the user read through the front section of the book to develop a familiarity with the layout of the book and with the system of symbols and abbreviations used. The Table of Contents should help to guide the user.

Vehicle Identification Numbers (VIN)

VIN ranges are presented throughout the book in the following manner:

→ VIN 123456 indicates “up to VIN 123456”; VIN 123456 → indicates “from VIN 123456 on”.

Jaguar S-TYPE Electrical System Architecture

Power Supplies

The Jaguar S-TYPE electrical system is a supply-side switched system. The ignition switch directly carries much of the ignition switched power supply load. Power supply is provided via three methods: direct battery power supply, ignition switched power supply, and “Switched System Power Supply”. The “Switched System Power Supply” circuit is controlled via the GECM (General Electronic Control Module) and the RECM (Rear Electronic Control Module). Refer to Figure 01.6 for circuit activation details.

Fuse Boxes

The electrical harness incorporates two hard-wired power distribution fuse boxes: the Front Power Distribution Fuse Box located in the engine compartment and the Rear Power Distribution Fuse Box located in the trunk. A serviceable Primary Junction Fuse Box is located in the front right-hand foot well. All fuses and relays (except the trailer towing accessory kit) are located in the two fuse boxes.

Vehicle Networks

The New Jaguar S-TYPE employs three different networks: a CAN (Controller Area Network) for high-speed power train communications, an SCP (Standard Corporate Protocol) network for slower speed body systems communications, and a D2B (Optical) Network for very high-speed “real-time” audio data transfer. The D2B Network is a fiber optic network with a gateway to the remaining vehicle networks via the Audio Unit. Technician access to the three networks and the Serial Data Link is via the Data Link Connector.

Ground Studs

Circuit ground connections are made at body studs located throughout the vehicle. There are no separate power and logic grounding systems; however, there are a certain number of components that use unique ground points.

S-TYPE INSTRUMENT PANEL

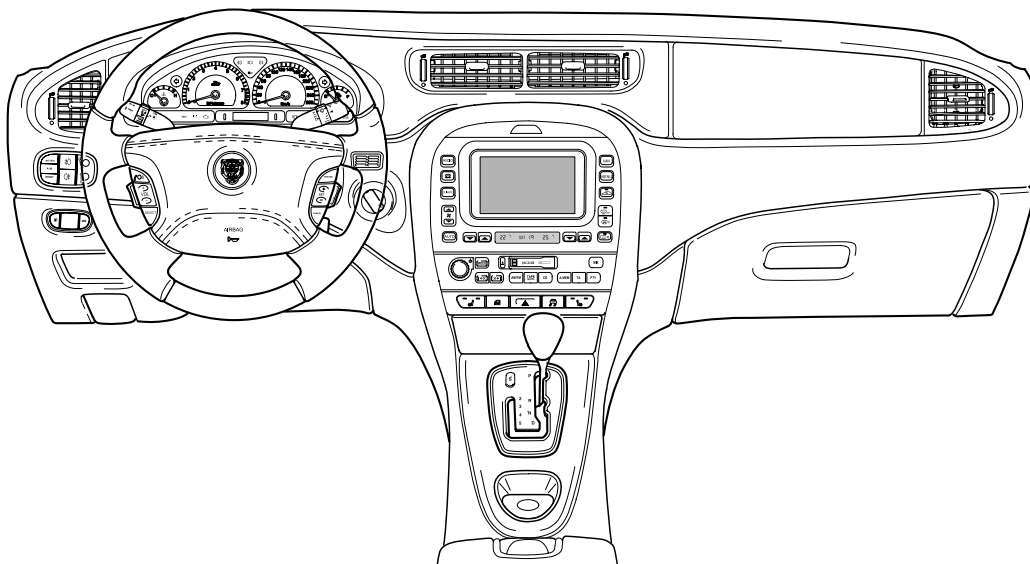



ACCESSORY CONNECTOR	Fig. 19.1	AUXILIARY LIGHTING SWITCH	Fig. 07.1
ACCESSORY RELAY	Fig. 19.1	Fig. 08.1
ACTIVE BRAKE BOOSTER	Fig. 05.1	Fig. 08.2
ACTIVE BRAKE BOOSTER SOLENOID	Fig. 05.1	Fig. 08.3
ACTIVE SECURITY SOUNDER	Fig. 12.3	Fig. 08.5
ADAPTIVE DAMPING CONTROL MODULE	Fig. 05.4	Fig. 09.2
.....	Fig. 20.2	BATTERY	Fig. 01.1
ADAPTIVE SPEED CONTROL CHIME MODULE	Fig. 05.3	Fig. 02.1
ADAPTIVE SPEED CONTROL CONTROL MODULE	Fig. 05.3	Fig. 02.2
.....	Fig. 20.1	Fig. 08.4
AIR CLEANER SOLENOID VALVE	Fig. 03.6	BLOWER MOTOR	Fig. 06.1
AIR CONDITIONING COMPRESSOR CLUTCH	Fig. 03.6	BLOWER MOTOR RELAY	Fig. 06.1
.....	Fig. 03.2	BRAKE CANCEL SWITCH	Fig. 03.2
.....	Fig. 03.4	Fig. 03.4
.....	Fig. 03.4	Fig. 03.6
AIR CONDITIONING COMPRESSOR CLUTCH RELAY	Fig. 03.2	BRAKE FLUID RESERVOIR	Fig. 05.1
.....	Fig. 03.4	BRAKE ON / OFF SWITCH	Fig. 03.1
.....	Fig. 03.6	Fig. 03.3
AIR CONDITIONING CONTROL MODULE – PANEL	Fig. 06.1	Fig. 03.5
.....	Fig. 09.2	Fig. 08.3
.....	Fig. 10.2	BRAKE PRESSURE SENSOR	Fig. 05.1
.....	Fig. 20.1	CD AUTOCHANGER	Fig. 15.1
AIR CONDITIONING CONTROL MODULE – REMOTE	Fig. 06.1	Fig. 15.2
.....	Fig. 10.2	Fig. 20.3
.....	Fig. 20.1	Fig. 20.4
AIR CONDITIONING PRESSURE SENSOR	Fig. 03.2	Fig. 20.5
.....	Fig. 03.4	CELLULAR PHONE CONTROL MODULE	Fig. 16.1
.....	Fig. 03.6	Fig. 16.2
AIRBAG IGNITERS, EXCEPT PASSENGER DUAL	Fig. 17.1	Fig. 16.3
AIRBAG IGNITERS – PASSENGER DUAL	Fig. 17.2	Fig. 16.4
AM / FM ANTENNA AMPLIFIER	Fig. 15.1	Fig. 20.3
.....	Fig. 15.2	Fig. 20.4
AMBIENT TEMPERATURE SENSOR	Fig. 06.1	Fig. 20.5
APP SENSOR	Fig. 03.1	CENTER CONSOLE SWITCH PACK	Fig. 05.1
.....	Fig. 03.3	Fig. 08.1
.....	Fig. 03.5	Fig. 08.2
AUDIO UNIT	Fig. 09.2	Fig. 08.3
.....	Fig. 12.3	Fig. 09.2
.....	Fig. 15.1	Fig. 11.6
.....	Fig. 15.2	Fig. 12.1
.....	Fig. 16.1	Fig. 12.2
.....	Fig. 16.2	Fig. 14.1
.....	Fig. 16.3	CIGAR LIGHTER	Fig. 09.2
.....	Fig. 16.4	Fig. 19.1
.....	Fig. 16.5	CIGAR LIGHTER / POWER POINT RELAY	Fig. 19.1
.....	Fig. 20.2	CKP SENSOR (V6)	Fig. 03.1
.....	Fig. 20.3	CKP SENSOR (V8)	Fig. 03.3
.....	Fig. 20.4	Fig. 03.5
.....	Fig. 20.5	CLUTCH CANCEL SWITCH	Fig. 03.2
AUXILIARY COOLANT PUMP	Fig. 06.1	Fig. 04.1
AUXILIARY COOLANT PUMP RELAY	Fig. 06.1	CLUTCH PEDAL POSITION SENSOR	Fig. 04.1
		Fig. 05.2
		CLUTCH PEDAL SAFETY SWITCH	Fig. 02.1
		Fig. 04.1
		CMP SENSORS (V6)	Fig. 03.1



CMP SENSORS (V8)	Fig. 03.3	DRIVER SEAT POSITION SWITCH	Fig. 17.1
.....	Fig. 03.5	DUAL COOLANT CONTROL VALVE	Fig. 06.1
COLD AIR BYPASS ACTUATOR	Fig. 06.1	DUAL SOLAR SENSOR (CLIMATE CONTROL)	Fig. 06.1
COLUMN AND PEDAL ADJUST SWITCH	Fig. 10.1	DUAL SOLAR SENSOR (AUTO HEADLAMP)	Fig. 08.1
COOLING FAN MODULE	Fig. 03.2	Fig. 08.2
.....	Fig. 03.4	Fig. 08.3
.....	Fig. 03.6	DYNAMIC STABILITY CONTROL CONTROL MODULE	Fig. 05.1
COURTESY LAMPS	Fig. 09.1	Fig. 05.3
DAMPER SOLENOIDS	Fig. 05.4	Fig. 05.4
DATA LINK CONNECTOR	Fig. 20.1	Fig. 20.1
.....	Fig. 20.2	ECT SENSOR	Fig. 03.1
DEFROST MODE ACTUATOR	Fig. 06.1	Fig. 03.3
DISCHARGE TEMPERATURE SENSORS	Fig. 06.1	Fig. 03.5
DOOR LATCH ASSEMBLY – DRIVER	Fig. 09.1	EFT SENSOR (V6)	Fig. 03.1
.....	Fig. 10.1	EFT SENSOR (V8)	Fig. 03.3
.....	Fig. 12.1	Fig. 03.5
.....	Fig. 12.2	EGR VALVE (V8 N/A)	Fig. 03.3
.....	Fig. 12.3	EGR VALVE (V8 SC)	Fig. 03.5
.....	Fig. 14.1	ELECTROCHROMIC REAR VIEW MIRROR AND COMPASS	Fig. 10.3
DOOR LATCH ASSEMBLY – LH REAR	Fig. 09.1	ELECTRONIC ROAD PRICING MODULE	Fig. 19.1
.....	Fig. 12.1	EMS CONTROL RELAY	Fig. 01.7
.....	Fig. 12.2	ENGINE CONTROL MODULE	Fig. 01.7
.....	Fig. 12.3	Fig. 02.1
DOOR LATCH ASSEMBLY – PASSENGER	Fig. 09.1	Fig. 02.2
.....	Fig. 12.1	Fig. 03.1
.....	Fig. 12.2	Fig. 03.2
.....	Fig. 12.3	Fig. 03.3
DOOR LATCH ASSEMBLY – RH REAR	Fig. 09.1	Fig. 03.4
.....	Fig. 12.1	Fig. 03.5
.....	Fig. 12.2	Fig. 03.6
.....	Fig. 12.3	Fig. 04.1
DOOR MIRRORS	Fig. 10.2	Fig. 05.3
DOOR SWITCH PACK – DRIVER	Fig. 09.2	Fig. 12.3
.....	Fig. 10.1	Fig. 20.1
.....	Fig. 10.2	Fig. 20.2
.....	Fig. 10.3	ENGINE COOLANT LEVEL SENSOR	Fig. 07.1
.....	Fig. 11.1	EOT SENSOR	Fig. 03.1
.....	Fig. 14.1	Fig. 03.3
DOOR SWITCH PACK – LH REAR	Fig. 14.1	Fig. 03.5
DOOR SWITCH PACK – PASSENGER	Fig. 14.1	EVAP CANISTER CLOSE VALVE	Fig. 03.1
DOOR SWITCH PACK – RH REAR	Fig. 14.1	Fig. 03.3
DRIVER DOOR CONTROL MODULE	Fig. 09.1	Fig. 03.5
.....	Fig. 10.1	EVAP CANISTER PURGE VALVE	Fig. 03.1
.....	Fig. 10.2	Fig. 03.3
.....	Fig. 10.3	Fig. 03.5
.....	Fig. 11.1	EXTERNAL TRUNK RELEASE SWITCH	Fig. 12.1
.....	Fig. 12.1	Fig. 12.2
.....	Fig. 12.2	FASCIA LAMPS	Fig. 09.1
.....	Fig. 12.3	FLOOR MODE ACTUATOR	Fig. 06.1
.....	Fig. 14.1	FRESH / RECIRCULATION ACTUATOR	Fig. 06.1
.....	Fig. 20.2	FRONT FOG LAMPS	Fig. 08.1
DRIVER SEAT CONTROL MODULE	Fig. 11.1	Fig. 08.2
.....	Fig. 11.2		
.....	Fig. 20.2		



FRONT FOG LAMP RELAY	Fig. 08.1	GENERAL ELECTRONIC CONTROL MODULE	Fig. 01.6
.....	Fig. 08.2	Fig. 05.2
FRONT POWER DISTRIBUTION FUSE BOX	Fig. 01.1	Fig. 07.1
.....	Fig. 01.2	Fig. 08.1
.....	Fig. 01.5	Fig. 08.2
.....	Fig. 01.7	Fig. 09.1
.....	Fig. 02.1	Fig. 09.2
.....	Fig. 02.2	Fig. 10.1
.....	Fig. 03.1	Fig. 10.2
.....	Fig. 03.2	Fig. 12.1
.....	Fig. 03.3	Fig. 12.2
.....	Fig. 03.4	Fig. 12.3
.....	Fig. 03.5	Fig. 13.1
.....	Fig. 03.6	Fig. 19.1
.....	Fig. 06.1	Fig. 20.2
.....	Fig. 08.1	GENERATOR (V6)	Fig. 02.1
.....	Fig. 08.2	GENERATOR (V8)	Fig. 02.2
.....	Fig. 12.3	GLOVE BOX LAMP	Fig. 09.1
.....	Fig. 13.1	HAND SET RECEIVER	Fig. 16.1
.....	Fig. 19.1	Fig. 16.2
FTP SENSOR	Fig. 03.1	Fig. 16.3
.....	Fig. 03.3	Fig. 16.4
.....	Fig. 03.5	HEADLAMP LEVELING ACTUATORS	Fig. 08.5
FUEL FLAP AND TRUNK RELEASE SWITCH PACK	Fig. 05.3	HEADLAMP LEVELING CONTROL MODULE	Fig. 08.5
.....	Fig. 09.2	Fig. 20.1
.....	Fig. 12.1	Fig. 20.2
.....	Fig. 12.2	HEADLAMP UNITS (NOT HID)	Fig. 08.1
FUEL FLAP RELAY	Fig. 12.1	Fig. 08.2
.....	Fig. 12.2	HEATED REAR WINDOW	Fig. 10.2
FUEL FLAP RELEASE SOLENOID	Fig. 12.1	Fig. 15.1
.....	Fig. 12.2	Fig. 15.2
FUEL INJECTORS (V6)	Fig. 03.2	HEATED REAR WINDOW RELAY	Fig. 10.2
FUEL INJECTORS (V8 N/A)	Fig. 03.4	HID HEADLAMP UNITS	Fig. 08.5
FUEL INJECTORS (V8 SC)	Fig. 03.6	HID RELAYS	Fig. 08.2
FUEL LEVEL SENSORS	Fig. 07.1	HIGH-MOUNTED STOP LAMP	Fig. 08.3
FUEL PUMP 1	Fig. 03.2	Fig. 08.4
.....	Fig. 03.4	HO2 SENSORS	Fig. 03.1
.....	Fig. 03.6	Fig. 03.3
FUEL PUMP 2	Fig. 03.6	Fig. 03.5
FUEL PUMP 2 MODULE	Fig. 03.6	HO2S RELAY	Fig. 01.7
FUEL PUMP RELAY	Fig. 03.2	HOOD AJAR SWITCH	Fig. 12.3
.....	Fig. 03.4	HORN RELAY	Fig. 12.3
.....	Fig. 03.6	Fig. 19.1
		HORNS	Fig. 12.3
		Fig. 19.1
		HUMIDITY SENSOR	Fig. 06.1
		IAT SENSOR 2	Fig. 03.5
		IGNITION CAPACITOR	Fig. 03.2
		Fig. 03.4
		Fig. 03.6
		IGNITION COIL RELAY	Fig. 01.7



IGNITION MODULES AND COILS	Fig. 03.2	LUMBAR PUMP – PASSENGER	Fig. 11.4
.....	Fig. 03.4	Fig. 11.5
.....	Fig. 03.6	LUMBAR SOLENOIDS – DRIVER	Fig. 11.2
IGNITION SWITCH	Fig. 01.1	LUMBAR SOLENOIDS – PASSENGER	Fig. 11.5
.....	Fig. 01.4	MAF SENSOR	Fig. 03.1
.....	Fig. 01.5	Fig. 03.3
.....	Fig. 02.1	Fig. 03.5
.....	Fig. 02.2	MAIN LIGHTING SWITCH (COLUMN SWITCHGEAR)	Fig. 07.1
.....	Fig. 04.1	Fig. 08.1
.....	Fig. 07.1	Fig. 08.2
.....	Fig. 12.3	Fig. 08.3
IMPACT SENSORS	Fig. 17.1	Fig. 09.2
IMT SOLENOID VALVES	Fig. 03.1	MAP LAMPS	Fig. 09.1
IN-CAR TEMPERATURE SENSOR	Fig. 06.1	MAP SENSOR (V6)	Fig. 03.1
INCLINATION SENSOR	Fig. 12.3	MAP SENSOR (V8 N/A)	Fig. 03.3
INERTIA SWITCH	Fig. 01.5	MAP SENSOR (V8 SC)	Fig. 03.5
INSTRUMENT CLUSTER	Fig. 02.1	NAVIGATION CONTROL MODULE	Fig. 16.1
.....	Fig. 02.2	Fig. 16.2
.....	Fig. 05.3	Fig. 16.3
.....	Fig. 05.4	Fig. 16.4
.....	Fig. 07.1	Fig. 16.6
.....	Fig. 08.1	Fig. 16.7
.....	Fig. 08.2	Fig. 16.8
.....	Fig. 08.3	Fig. 20.2
.....	Fig. 09.1	Fig. 20.3
.....	Fig. 09.2	Fig. 20.4
.....	Fig. 10.1	Fig. 20.5
.....	Fig. 10.2	NAVIGATION GPS ANTENNA	Fig. 16.6
.....	Fig. 12.3	Fig. 16.7
.....	Fig. 19.1	Fig. 16.8
.....	Fig. 20.1	NAVIGATION SCREEN AND TELEMATICS DISPLAY	Fig. 16.6
.....	Fig. 20.2	Fig. 16.7
INTERCOOLER PUMP	Fig. 03.6	Fig. 16.8
IP SENSOR (V6)	Fig. 03.1	NEUTRAL SWITCH	Fig. 04.1
IP SENSOR (V8 N/A)	Fig. 03.3	Fig. 05.2
IP SENSOR (V8 S/C)	Fig. 03.5	OCCUPANCY SENSING CONTROL MODULE	Fig. 17.2
J GATE MODULE	Fig. 04.1	OIL PRESSURE SWITCH	Fig. 07.1
.....	Fig. 09.2	PANEL MODE ACTUATOR	Fig. 06.1
.....	Fig. 20.1	PARKING AID CONTROL MODULE	Fig. 18.1
JaguarNet GPS ANTENNA	Fig. 16.1	Fig. 20.2
.....	Fig. 16.2	PARKING AID SENSORS	Fig. 18.1
.....	Fig. 16.3	PARKING AID SOUNDER	Fig. 18.1
.....	Fig. 16.4	PARKING BRAKE CONTROL MODULE	Fig. 04.1
KNOCK SENSORS (V6)	Fig. 03.1	Fig. 05.2
KNOCK SENSORS (V8)	Fig. 03.3	Fig. 20.2
.....	Fig. 03.5	PARKING BRAKE MOTOR	Fig. 05.2
LATERAL ACCELEROMETER	Fig. 05.4	PARKING BRAKE SWITCH	Fig. 05.2
LH WINDSHIELD HEATER	Fig. 06.1	PASSENGER AIRBAG DEACTIVATED INDICATOR LAMP	Fig. 17.2
LH WINDSHIELD HEATER RELAY	Fig. 06.1	PASSENGER SEAT WEIGHT PRESSURE SENSOR	Fig. 17.2
LICENSE PLATE LAMPS	Fig. 08.3	PASSENGER SEAT WEIGHT SENSING CONTROL MODULE	Fig. 17.2
.....	Fig. 08.4		
LUMBAR PUMP – DRIVER	Fig. 11.1		
.....	Fig. 11.2		
.....	Fig. 11.3		



PASSIVE ANTI-THEFT SYSTEM TRANSCIEVER	Fig. 02.1	REMOTE KEYLESS ENTRY MODULE	Fig. 12.1
.....	Fig. 02.2	Fig. 12.3
.....	Fig. 12.3	RESTRAINTS CONTROL MODULE	Fig. 17.1
PASSIVE SECURITY SOUNDER	Fig. 12.3	Fig. 17.2
PEDAL ADJUST MOTOR	Fig. 10.1	Fig. 20.2
PEDAL FORCE SWITCH	Fig. 05.1	REVERSE SWITCH	Fig. 04.1
PEDAL TRAVEL SENSOR	Fig. 05.1	Fig. 08.3
POWER AMPLIFIER	Fig. 15.2	RIDE HEIGHT SENSORS	Fig. 08.5
.....	Fig. 20.3	ROOF CONSOLE	Fig. 09.1
.....	Fig. 20.4	Fig. 09.2
.....	Fig. 20.5	Fig. 12.3
POWER POINT	Fig. 09.2	Fig. 14.1
.....	Fig. 19.1	Fig. 16.1
POWER WASH PUMP	Fig. 13.1	Fig. 16.2
POWER WASH RELAY	Fig. 13.1	Fig. 16.3
PRIMARY JUNCTION FUSE BOX	Fig. 01.3	Fig. 16.4
.....	Fig. 01.4	Fig. 16.5
.....	Fig. 01.5	Fig. 16.8
.....	Fig. 01.6	Fig. 19.1
.....	Fig. 02.1	Fig. 20.2
.....	Fig. 02.2	SEAT BACK HEATERS	Fig. 11.6
.....	Fig. 09.2	SEAT BELT PRETENSIONER IGNITERS	Fig. 17.1
.....	Fig. 19.1	SEAT BELT SWITCHES	Fig. 17.1
RAIN SENSING MODULE	Fig. 13.1	SEAT CUSHION HEATERS	Fig. 11.6
RAIN SENSING UNIT	Fig. 13.1	SEAT HEATER MODULES	Fig. 11.6
REAR ELECTRONIC CONTROL MODULE	Fig. 01.6	SEAT MOTORS – PASSENGER	Fig. 11.4
.....	Fig. 03.2	SEAT MOTORS AND POSITION SENSORS – DRIVER	Fig. 11.1
.....	Fig. 03.4	Fig. 11.2
.....	Fig. 03.6	Fig. 11.3
.....	Fig. 05.4	SEAT MOTORS AND POSITION SENSORS – PASSENGER	Fig. 11.5
.....	Fig. 07.1	SEAT SWITCH PACK – DRIVER	Fig. 11.1
.....	Fig. 08.3	Fig. 11.2
.....	Fig. 08.4	Fig. 11.3
.....	Fig. 09.1	SEAT SWITCH PACK – PASSENGER	Fig. 11.4
.....	Fig. 10.2	Fig. 11.5
.....	Fig. 10.3	SECURITY INDICATOR	Fig. 12.3
.....	Fig. 12.1	SIDE MARKERS	Fig. 08.1
.....	Fig. 12.2	Fig. 08.2
.....	Fig. 12.3	SIDE MARKER LAMPS	Fig. 08.3
.....	Fig. 14.1	SLIDING ROOF CONTROL MODULE	Fig. 14.1
.....	Fig. 20.2	SPATIAL SENSORS	Fig. 17.2
REAR POWER DISTRIBUTION FUSE BOX	Fig. 01.1	SPEAKERS	Fig. 15.1
.....	Fig. 01.2	Fig. 15.2
.....	Fig. 01.3	STARTER MEGAFUSE	Fig. 01.1
.....	Fig. 01.4	Fig. 02.1
.....	Fig. 01.5	Fig. 02.2
.....	Fig. 01.6	STARTER MOTOR	Fig. 02.1
.....	Fig. 03.2	Fig. 02.2
.....	Fig. 03.4	STARTER RELAY	Fig. 02.1
.....	Fig. 03.6	Fig. 02.2
.....	Fig. 06.1	STEERING ANGLE SENSOR	Fig. 05.1
.....	Fig. 10.2		
.....	Fig. 12.1		
.....	Fig. 12.2		
.....	Fig. 19.1		
REAR POWER DISTRIBUTION FUSE BOX MEGAFUSE	Fig. 01.1		











STEERING COLUMN LOCK CONTROL MODULE	Fig. 12.3	TRANSMISSION CONTROL MODULE	Fig. 02.1
.....	Fig. 20.2	Fig. 02.2
STEERING COLUMN MOTOR, SOLENOIDS		Fig. 04.1
AND POSITION SENSORS	Fig. 10.1	Fig. 05.3
STEERING WHEEL AUDIO SWITCHES	Fig. 15.1	Fig. 20.1
.....	Fig. 15.2	TRUNK AJAR SWITCH	Fig. 09.1
.....	Fig. 16.3	Fig. 12.1
.....	Fig. 16.4	Fig. 12.2
.....	Fig. 16.5	Fig. 12.3
STEERING WHEEL HORN SWITCH	Fig. 19.1	TRUNK LAMP – LH	Fig. 09.1
STEERING WHEEL LIGHTING	Fig. 09.2	TRUNK LID LAMP	Fig. 09.1
STEERING WHEEL SPEED CONTROL SWITCHES	Fig. 03.2	TRUNK RELEASE SOLENOID	Fig. 12.1
.....	Fig. 03.4	Fig. 12.2
.....	Fig. 03.6	TURN REPEATERS	Fig. 08.1
.....	Fig. 05.3	Fig. 08.2
SUBWOOFERS	Fig. 15.2	TV ANTENNAS AND AMPLIFIERS	Fig. 16.7
SUN SHADE MOTOR	Fig. 19.1	Fig. 16.8
SUN VISOR LAMPS	Fig. 09.1	VALET SWITCH	Fig. 12.1
SWITCHED SYSTEM POWER RELAYS	Fig. 01.6	Fig. 12.2
TAIL LAMP UNITS	Fig. 08.3	VARIABLE ASSIST STEERING ACTUATOR	Fig. 05.2
.....	Fig. 08.4	VEHICLE INFORMATION ANTENNA	Fig. 16.8
TELEMATICS DISPLAY	Fig. 09.2	VEHICLE INFORMATION CONTROL MODULE	Fig. 16.8
.....	Fig. 16.1	VEHICLE INFORMATION SENSOR	Fig. 16.8
.....	Fig. 16.2	VERTICAL ACCELEROMETERS	Fig. 05.4
.....	Fig. 16.3	VOICE ACTIVATION CONTROL MODULE	Fig. 16.3
.....	Fig. 16.4	Fig. 16.4
TELEPHONE ANTENNA (BUMPER)	Fig. 16.1	Fig. 16.5
.....	Fig. 16.2	Fig. 20.3
.....	Fig. 16.3	Fig. 20.4
.....	Fig. 16.4	Fig. 20.5
TELEPHONE ANTENNA (WITH JaguarNet)	Fig. 16.1	VVT SOLENOID VALVES	Fig. 03.1
.....	Fig. 16.2	Fig. 03.3
.....	Fig. 16.3	WASHER FLUID LEVEL SWITCH	Fig. 07.1
.....	Fig. 16.4	Fig. 13.1
THROTTLE MOTOR (V6)	Fig. 03.1	WHEEL SPEED SENSORS	Fig. 05.1
THROTTLE MOTOR (V8 N/A)	Fig. 03.3	WINDOW MOTOR ASSEMBLIES	Fig. 14.1
THROTTLE MOTOR (V8 SC)	Fig. 03.5	WINDOW SWITCHES	Fig. 09.2
THROTTLE MOTOR RELAY	Fig. 03.1	WINDSHIELD WASHER PUMP	Fig. 13.1
.....	Fig. 03.3	WIPE / WASH SWITCH	Fig. 13.1
.....	Fig. 03.5	WIPER HIGH / LOW RELAY	Fig. 13.1
TP SENSOR	Fig. 03.1	WIPER MOTOR ASSEMBLY	Fig. 13.1
.....	Fig. 03.3	WIPER PARK HEATER / RH WINDSHIELD HEATER RELAY	Fig. 06.1
.....	Fig. 03.5	WIPER PARK HEATER OR RH WINDSHIELD HEATER	Fig. 06.1
TRAILER TOWING CONNECTORS	Fig. 08.4	WIPER PARK RELAY	Fig. 13.1
TRAILER TOWING CONTROL MODULE	Fig. 08.4	YAW RATE AND LATERAL ACCELERATION	
TRAILER TOWING JUNCTION BOX	Fig. 08.4	SENSORS CLUSTER	Fig. 05.1
TRAILER TOWING RELAY	Fig. 08.4		
TRANSIT ISOLATION RELAY	Fig. 01.1		
TRANSMISSION CAPACITORS	Fig. 04.1		













NOTE: In the examples on this page, an 'X' is used where a number would appear on an actual Figure.

Reference Symbols









-  Battery power supply
-  Ignition switched auxiliary power supply (key I, II)
-  Ignition switched power supply (key II, III)
-  Switched System Power Supply power supply
-  Engine Management System power supply
-  Figure number reference
-  Controller Area Network
-  Standard Corporate Protocol network
-  D2B network

Control Module Pin Symbols

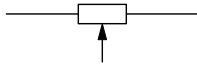
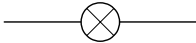
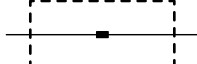
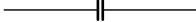
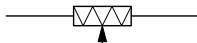
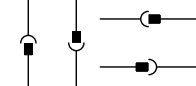
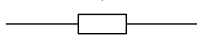
-  Input
-  Output
-  Battery voltage
-  Power ground
-  Sensor/signal supply V *
-  Sensor/signal ground **
-  CAN network
-  SCP network
-  D2B network
-  Serial and encoded data

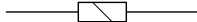
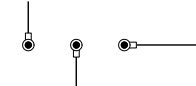
* May also indicate Reference Voltage.
 ** May also indicate Reference Ground or Logic Ground.
 Refer to Control Module Pin-Out Information.

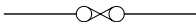
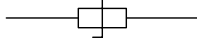
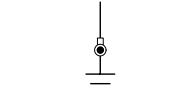
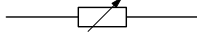
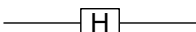
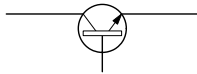
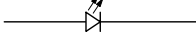
Wiring Symbols

- | | | | |
|----------------------------|---|--|---------------------------------|
| Splice |  |  | Motor |
| Simplified splice |  |  | Potentiometer |
| Bulb |  |  | Power distribution box terminal |
| Capacitor |  |  | Pressure transducer |
| Connector |  |  | Resistor |
| Diode |  |  | Solenoid |
| Eyelet and stud |  |  | Suppression diode |
| Fuse |  |  | Suppression resistor |
| Ground |  |  | Thermistor |
| Hall effect sensor |  |  | Transistor |
| Light emitting diode (LED) |  |  | Wire continued |
| | |  | Zener diode |

**Harness Codes**

AC	Climate Control Link
AT	Alarm Link
BF	Front Bumper Harness
BR	Rear Bumper Harness
CA	Cabin Harness
CP	Intercooler Pump Link
CV	Canister Vent Link
DD	Driver Door Harness
DM	Driver Memory Seat Harness
DT	Driver Door Trim Link
FC	Fascia Harness
FH	Front Harness
FL	LH Front Headlamp Link
FP	Fuel Pump Harness
FR	RH Front Headlamp Link
GB	Transmission Harness
IL	Fuel Injector Link
PD	Passenger Door
PI	Engine Harness
PN	Passenger Seat Harness
PT	Passenger Door Trim Link
RA	D2B Network Harness
RF	Roof Harness
SL	Solar Sensor Link
SR	Sliding Roof Harness
SW	Subwoofer Link
TT	Trailer Tow Harness

Wiring Color Codes

N	Brown	O	Orange
B	Black	S	Slate
W	White	L	Light
K	Pink	U	Blue
G	Green	P	Purple
R	Red	BRD	Braid
Y	Yellow	BOF	Black fiber optic (D2B Network)

Code Numbering

When numbering connectors, grounds and splices, Jaguar Engineering uses a three-position format: CA001, CA002, etc. Because space is limited in this Electrical Guide the codes have, in most cases, been shortened. Thus CA001-001 becomes CA1-1, CA002-001 becomes CA2-1, etc.



Grounds

On figures where LHD and RHD circuits are combined and the ground designation differs from LHD to RHD, the RHD ground code is shown in parentheses. If the ground designation is the same for LHD and RHD, only one ground code is used, with no parentheses.



Relays

All relays are located in the Front and Rear Power Distribution Boxes and the Primary Junction Fuse Box. Relays do not have a separate relay connector (base). All relays use the ISO pin numbering system (1, 2, 3, 4, 5). Each relay is identified by an “R” number unique only to the fuse box in which it is located.

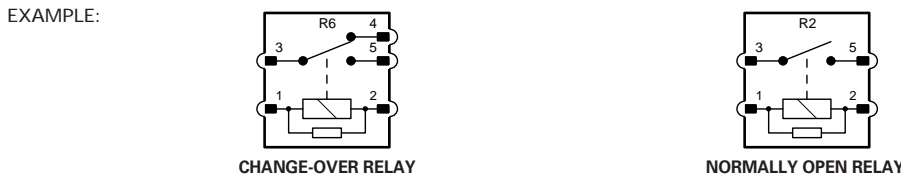

Fuses

All fuses are located in the Front and Rear Power Distribution Boxes and the Primary Junction Fuse Box. Each fuse is identified by an “F” number unique only to the fuse box in which it is located.

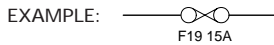

Networks

In most instances, networks are shown as a broken grey line to indicate that there is network communication between the depicted control modules. Refer to Figures 20.1, 20.2, 20.3, 20.4 and 20.5 for circuit details.

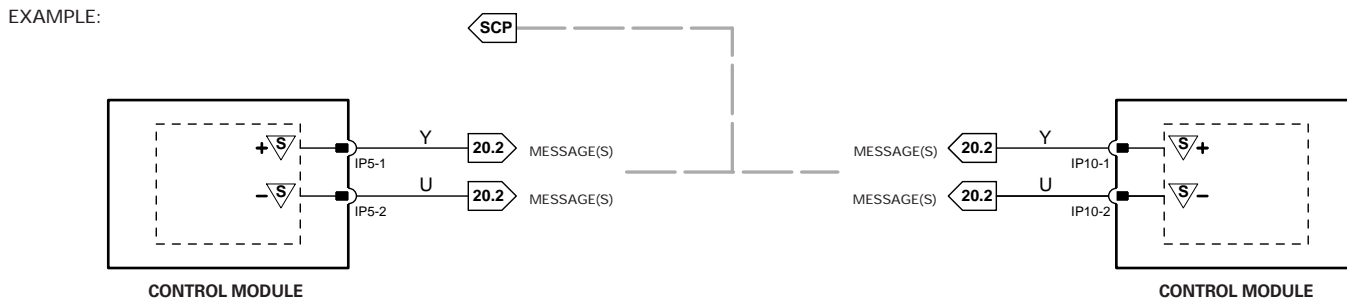

Component Depictions

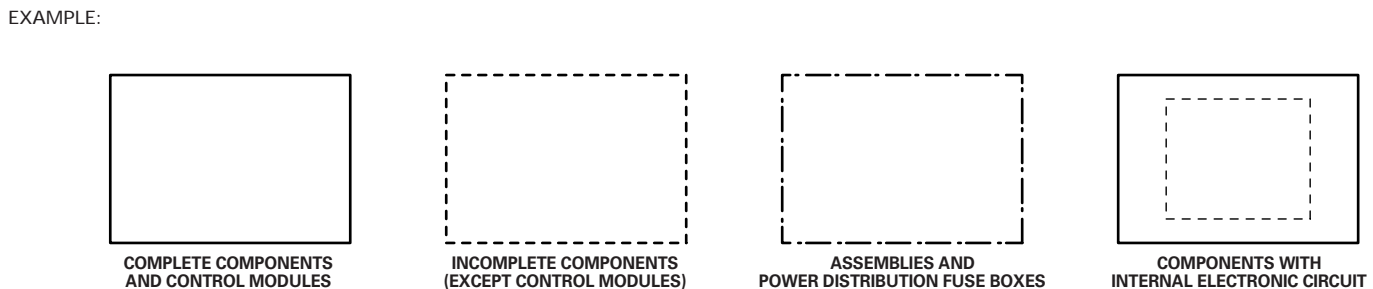

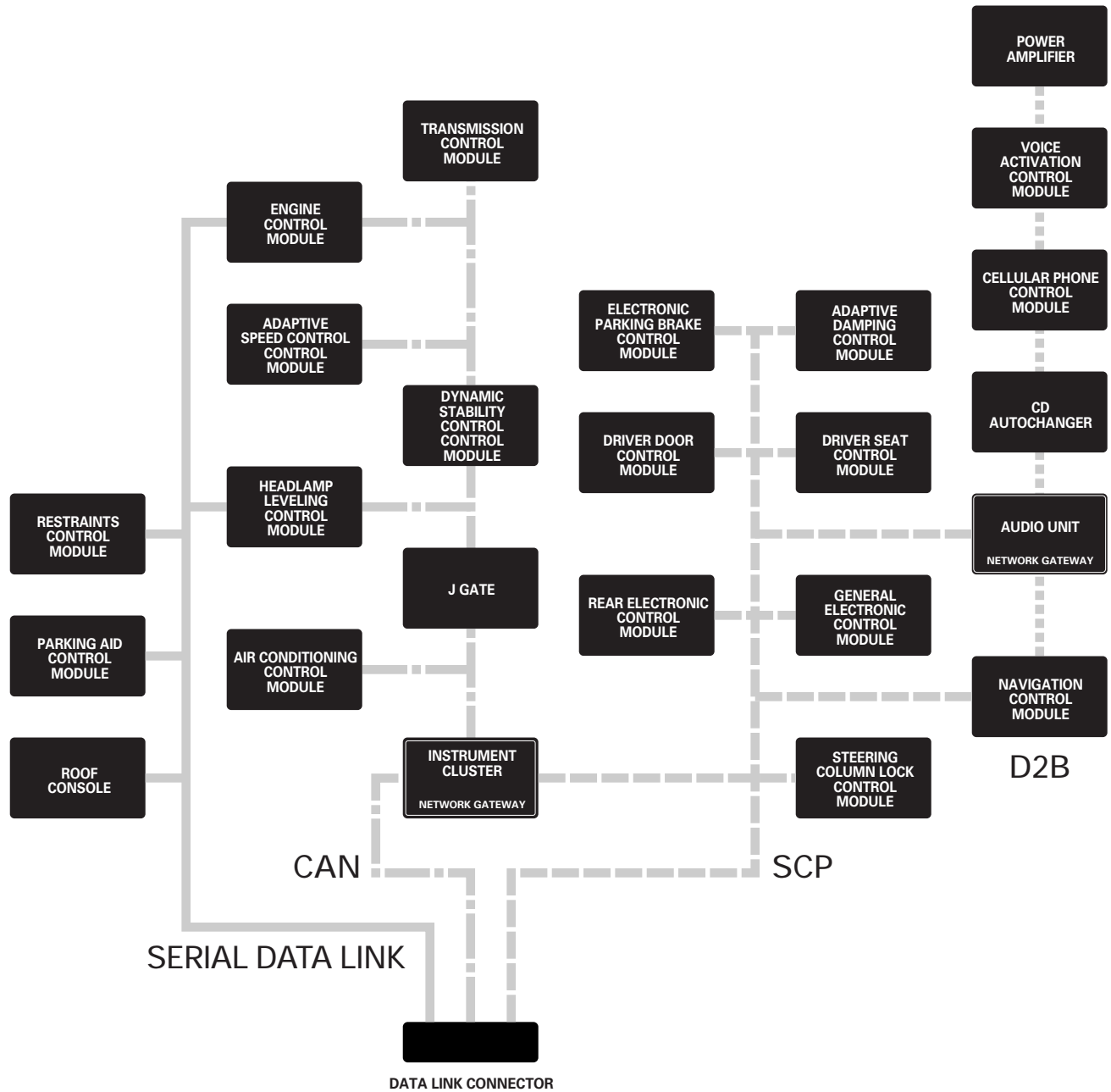

- CAN NETWORK
- . - . - . SCP NETWORK
- D2B NETWORK
- SERIAL DATA LINK

NOTE: TYPICAL S-TYPE NETWORK CONFIGURATION (AUTOMATIC TRANSMISSION; FULL OPTION SET). REFER TO FIGURES 20.1, 20.2, 20.3, 20.4 AND 20.5 FOR CIRCUIT DETAILS.

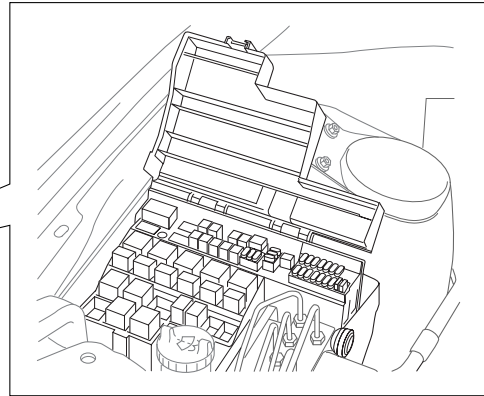
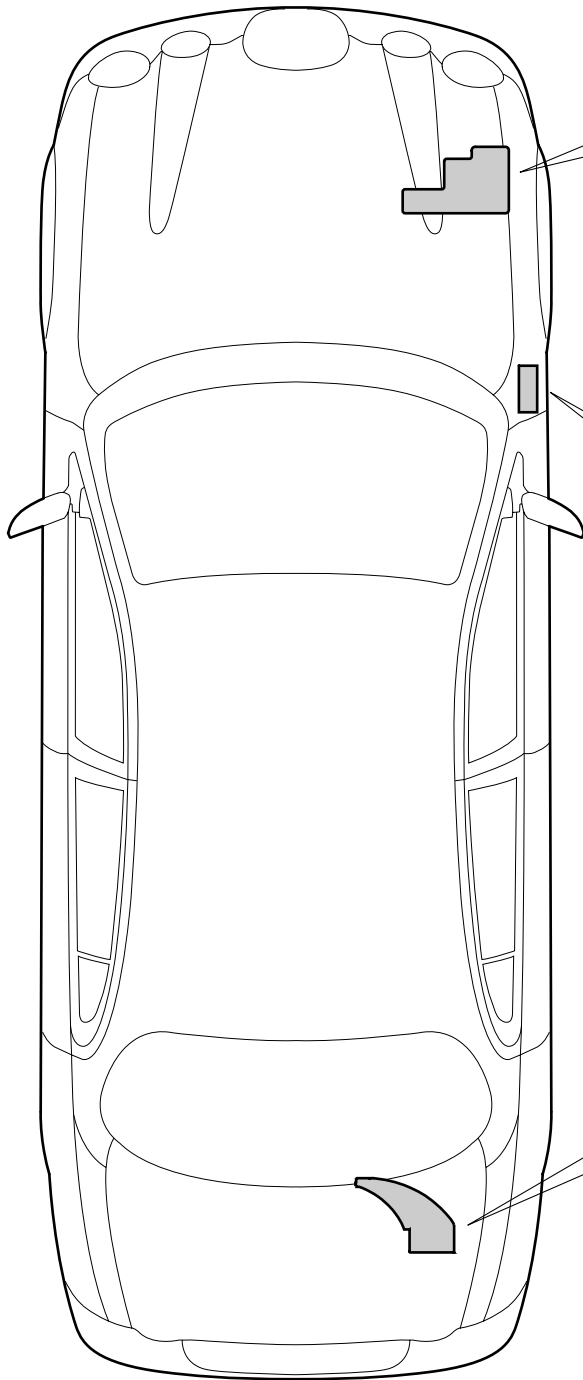

FRONT POWER DISTRIBUTION FUSE BOX

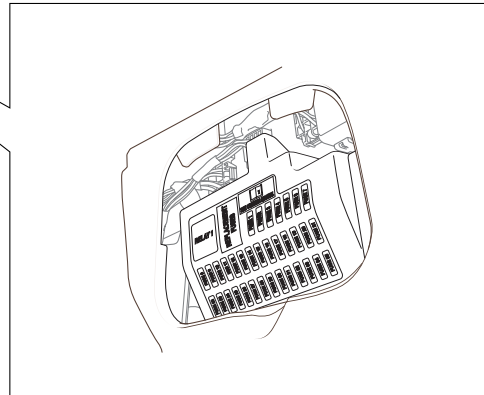

PRIMARY JUNCTION FUSE BOX

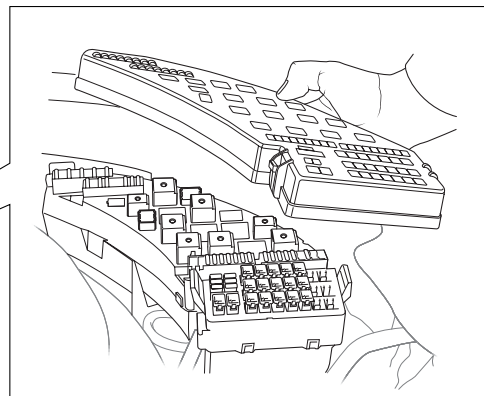

REAR POWER DISTRIBUTION FUSE BOX



FRONT POWER DISTRIBUTION FUSE BOX

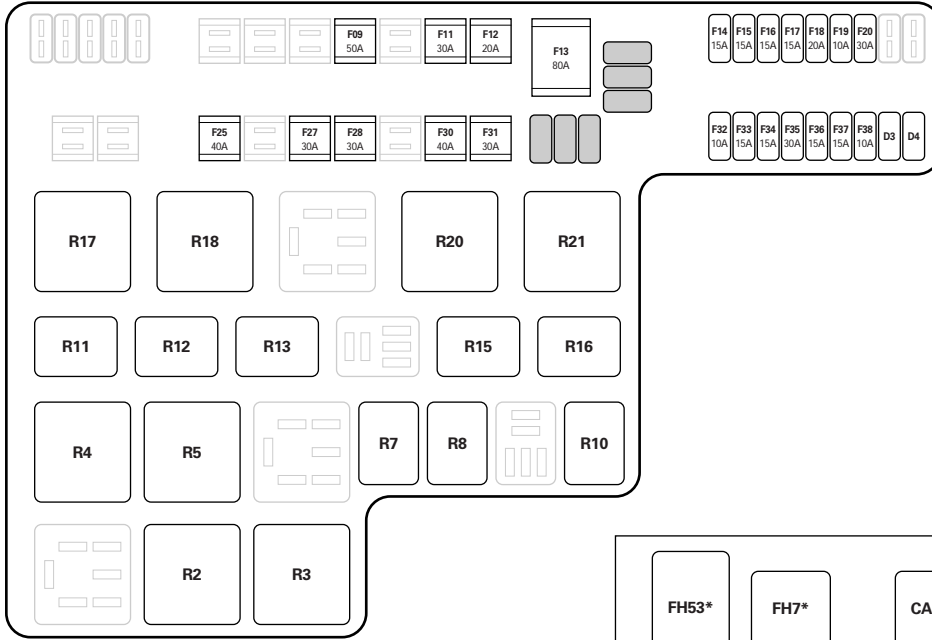

- R2 HEATED OXYGEN SENSOR RELAY
- R3 IGNITION COIL RELAY
- R4 THROTTLE MOTOR RELAY
- R5 EMS CONTROL RELAY
- R7 AUXILIARY COOLANT PUMP RELAY
- R8 A/C COMPRESSOR CLUTCH RELAY
- R10 LH HID RELAY
- R11 FRONT FOG LAMP RELAY
- R12 HORN RELAY
- R13 RH HID RELAY
- R15 WIPER HIGH / LOW RELAY
- R16 WIPER PARK RELAY
- R17 LH WINDSHIELD HEATER RELAY
- R18 POWER WASH RELAY
- R20 STARTER RELAY
- R21 WIPER PARK HEATER RELAY OR RH WINDSHIELD HEATER RELAY

R1 CIGAR LIGHTER / POWER POINT RELAY

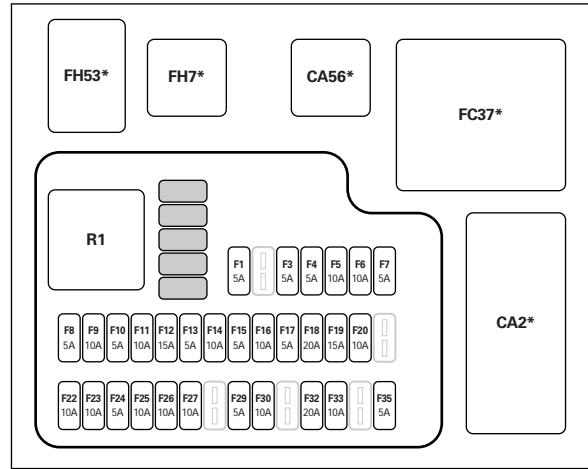

PRIMARY JUNCTION FUSE BOX

* PRIMARY JUNCTION FUSE BOX CONNECTORS

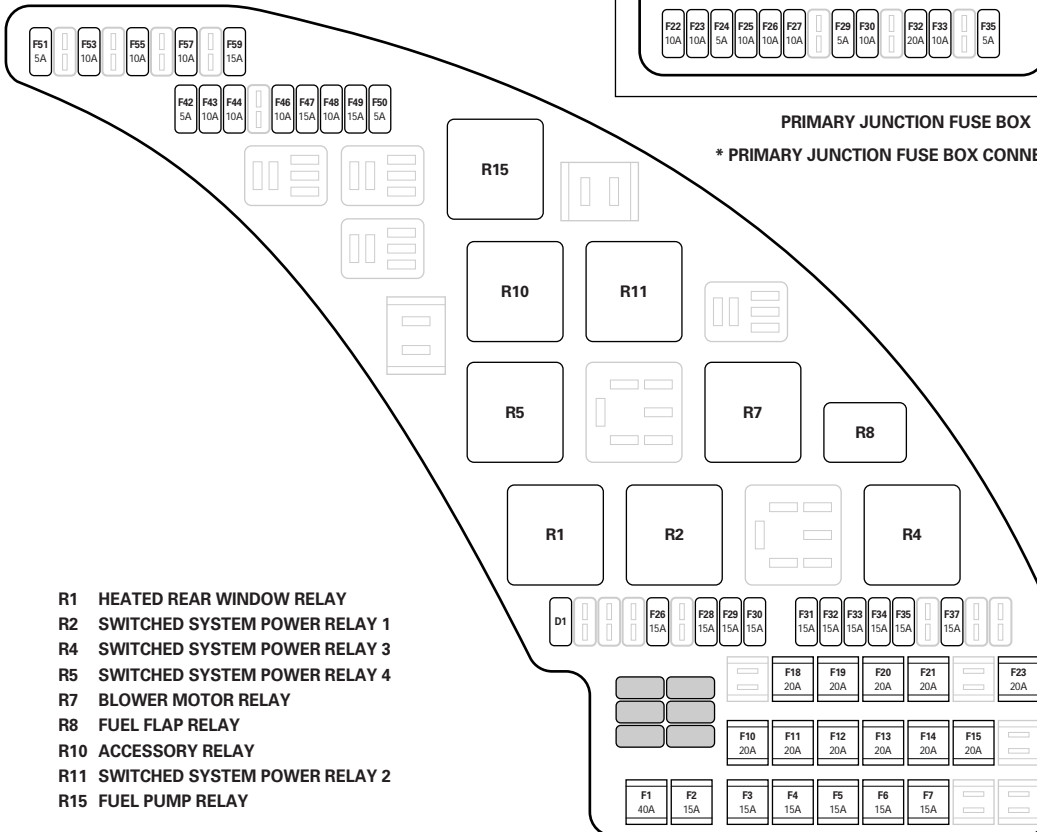

- R1 HEATED REAR WINDOW RELAY
- R2 SWITCHED SYSTEM POWER RELAY 1
- R4 SWITCHED SYSTEM POWER RELAY 3
- R5 SWITCHED SYSTEM POWER RELAY 4
- R7 BLOWER MOTOR RELAY
- R8 FUEL FLAP RELAY
- R10 ACCESSORY RELAY
- R11 SWITCHED SYSTEM POWER RELAY 2
- R15 FUEL PUMP RELAY

REAR POWER DISTRIBUTION FUSE BOX



LHD

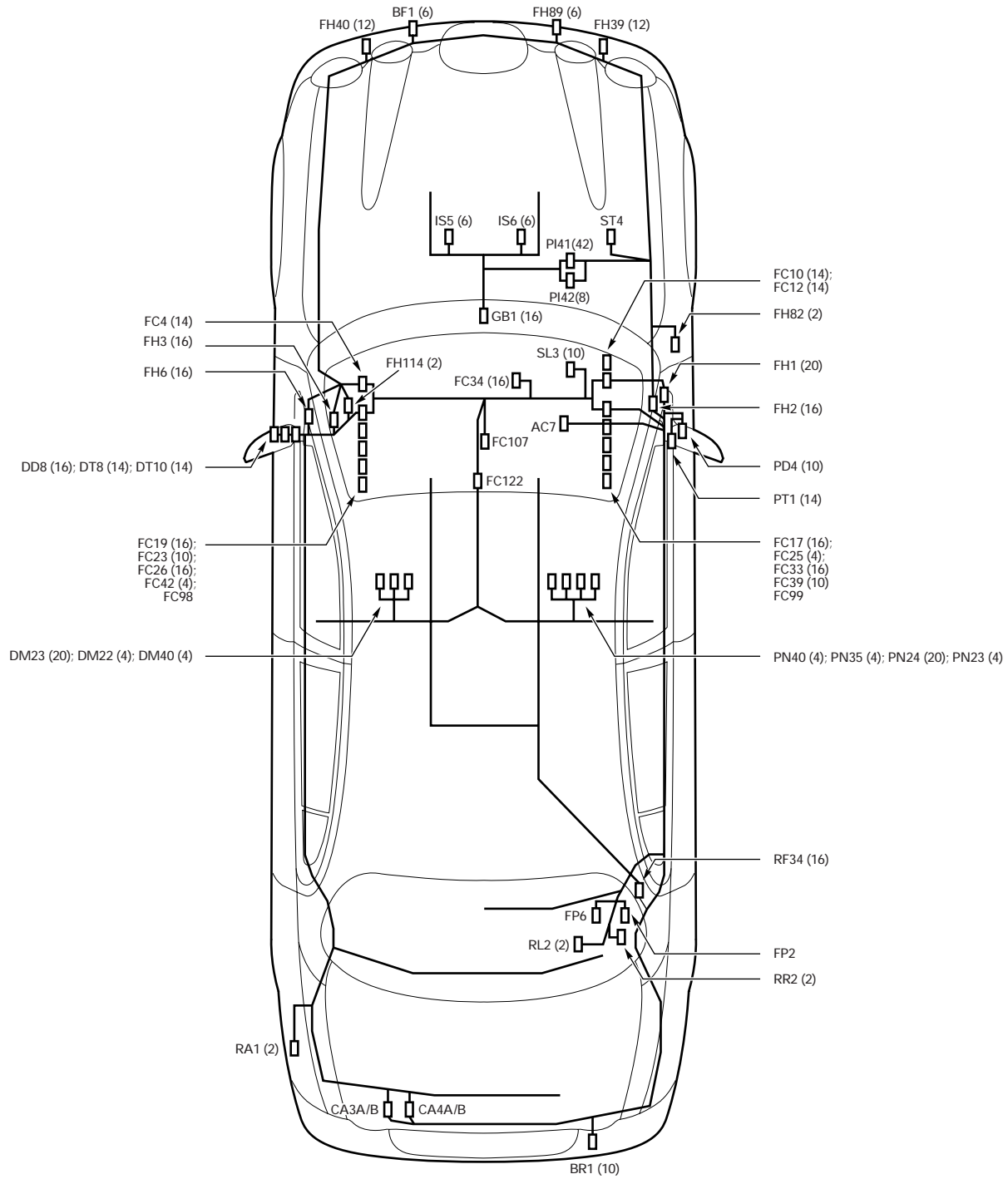

NOTE: WHERE THE INFORMATION IS AVAILABLE, THE NUMBER OF PINS CONTAINED IN A CONNECTOR IS SHOWN IN PARENTHESES.



RHD

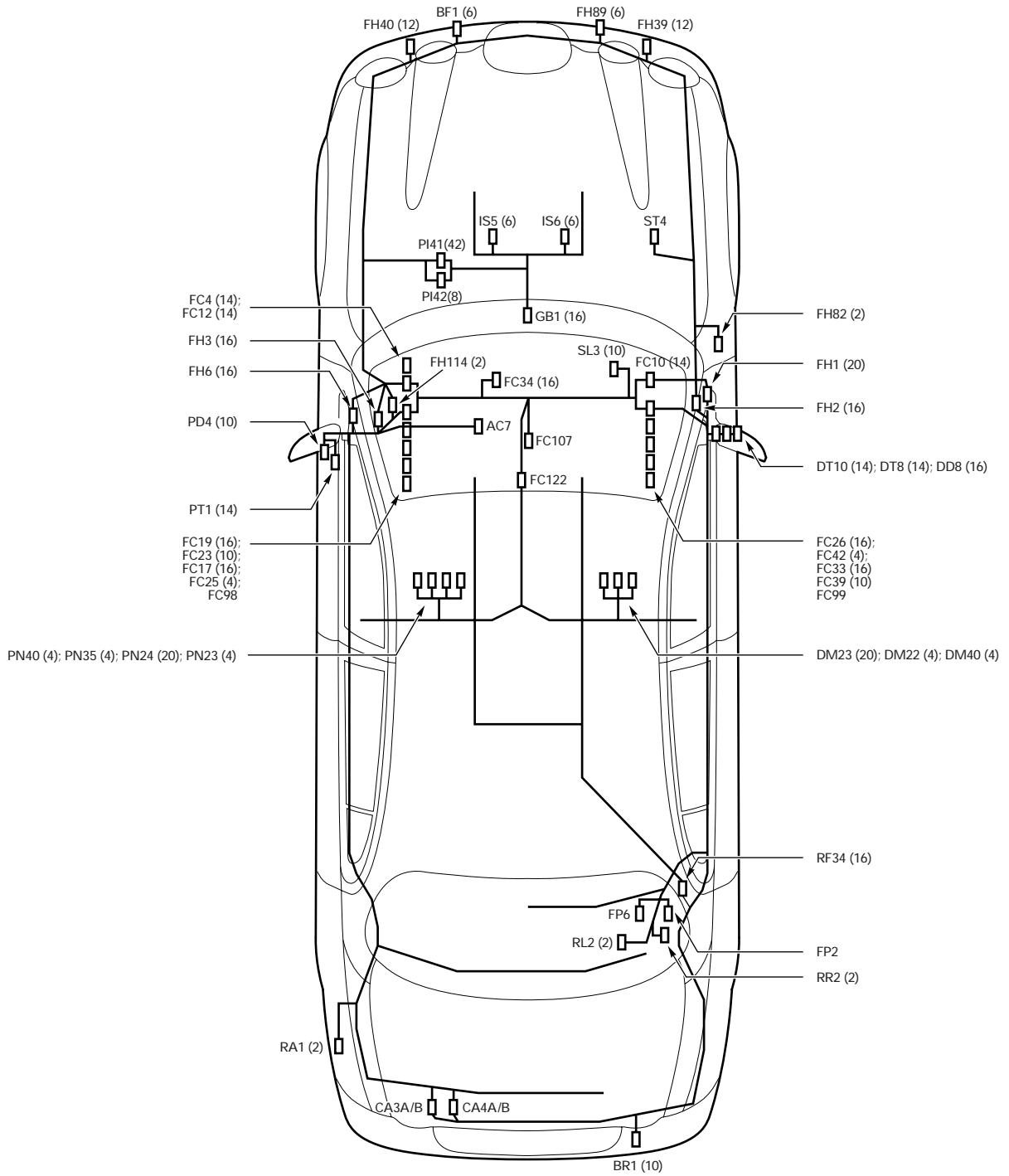

NOTE: WHERE THE INFORMATION IS AVAILABLE, THE NUMBER OF PINS CONTAINED IN A CONNECTOR IS SHOWN IN PARENTHESES.



LHD

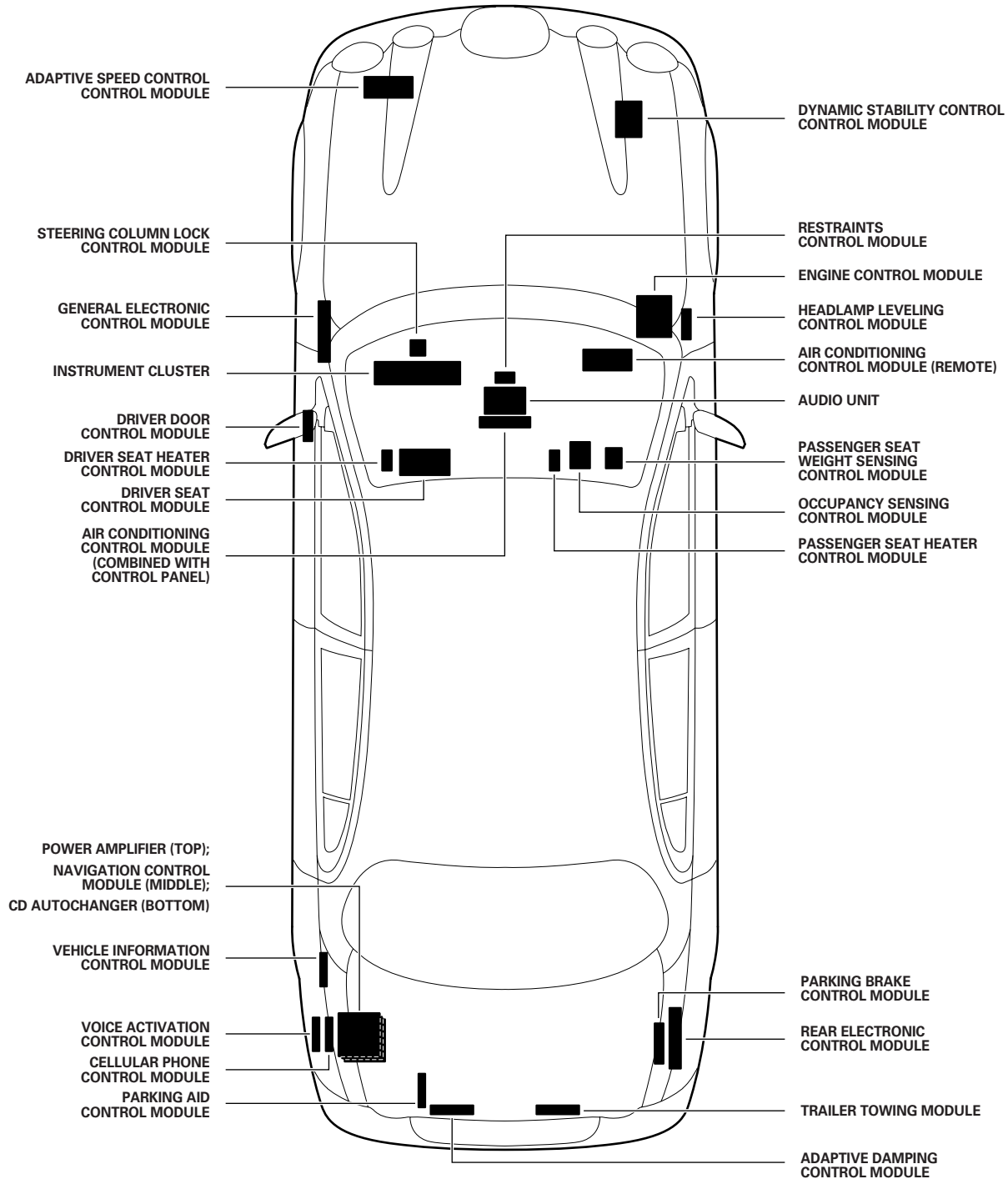

NOTE: THE TRANSMISSION CONTROL MODULE IS CONTAINED WITHIN THE TRANSMISSION.



RHD

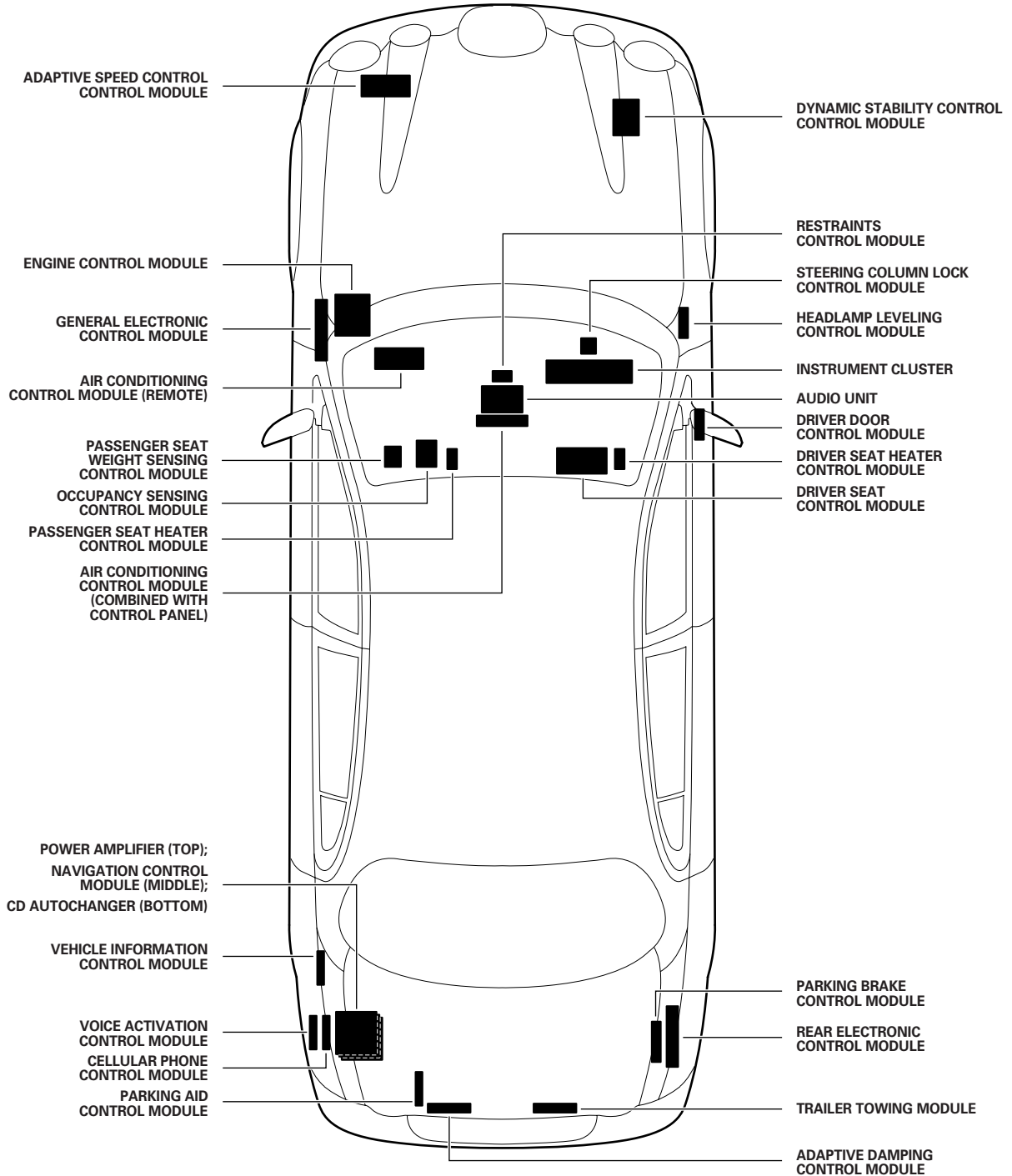

NOTE: THE TRANSMISSION CONTROL MODULE IS CONTAINED WITHIN THE TRANSMISSION.

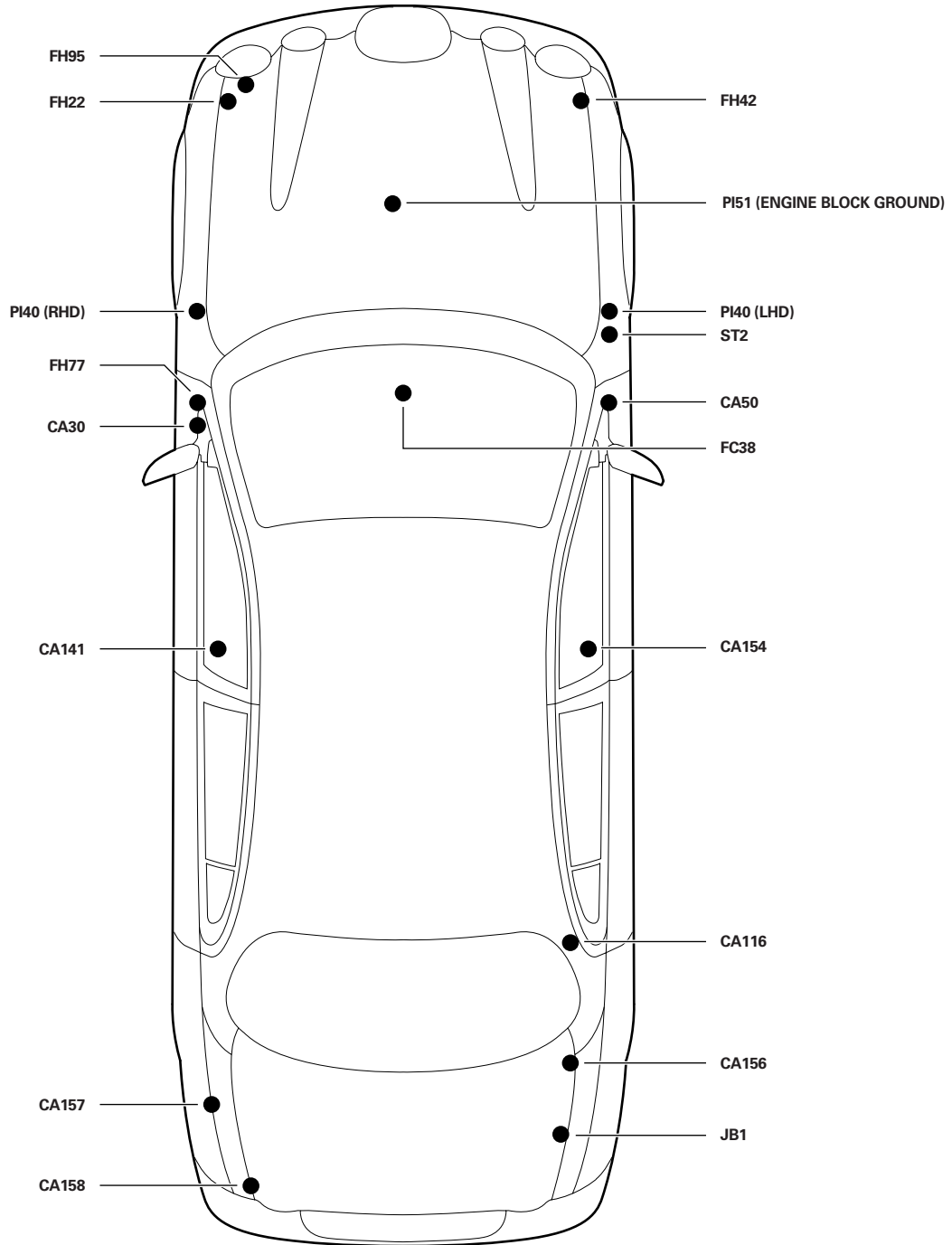



ENGINE CONTROL MODULE

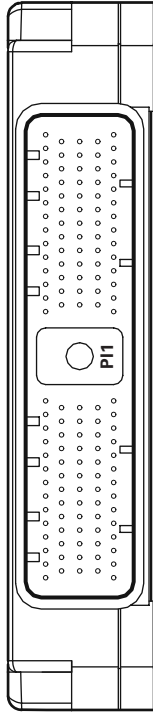

P11 / BLACK

107	108	109	110	111	112	113	114	115	116	117	118	119	120
G	N	Y	YU	B	UY	BG	BK	BG	B	RW	U	BO	BR
81	82	83	84	85	86	87	88	89	90	91	92	93	
B	B	R	Y	—	—	GU	Y	YR	GR	B	UY	RW	
55	56	57	58	59	60	61	62	63	64	65	66	67	
RW	RW	—	—	—	—	GW	GW	GR	YR	WR	UY	O	
29	30	31	32	33	34	35	36	37	38	39	40	41	
B	B	GR	—	WG	BG	—	O	B	OY	OG	BW	GO	
1	2	3	4	5	6	7	8	9	10	11	12	13	14
RU	RU	—	B	B	Y	GO	GO	U	GU	—	OY	—	—

V6

121	122	123	124	125	126	127	128	129	130	131	132	133	134
WU	—	G	Y	—	—	BK	N	N	BW	GB	YB	—	GU
94	95	96	97	98	99	100	101	102	103	104	105	106	
Y	R	—	—	N	N	N	BG	—	O	RG	W	RW	
68	69	70	71	72	73	74	75	76	77	78	79	80	
N	G	UY	U	—	—	U	R	Y	—	Y	Y	GR	GW
42	43	44	45	46	47	48	49	50	51	52	53	54	
—	BG	GW	BK	BK	WG	YG	—	WU	WU	GR	YR	B	
15	16	17	18	19	20	21	22	23	24	25	26	27	28
—	—	B	B	B	BG	BG	—	NR	WG	WG	—	WR	—

107	108	109	110	111	112	113	114	115	116	117	118	119	120
G	N	Y	YU	B	UY	BG	BK	BR	B	RW	U	BO	BG
81	82	83	84	85	86	87	88	89	90	91	92	93	
B	B	R	Y	—	—	GU	Y	YR	GR	B	UY	RW	
55	56	57	58	59	60	61	62	63	64	65	66	67	
RW	RW	—	—	—	—	GW	GW	GR	YR	WR	UY	O	
29	30	31	32	33	34	35	36	37	38	39	40	41	
B	B	GR	—	WG	BG	—	O	B	OY	OG	BW	GO	
1	2	3	4	5	6	7	8	9	10	11	12	13	14
RU	RU	—	B	B	Y	GO	GO	U	GU	—	OY	—	—

V8 N/A

121	122	123	124	125	126	127	128	129	130	131	132	133	134
WU	—	G	Y	—	—	BK	N	N	BW	GB	YB	—	GU
94	95	96	97	98	99	100	101	102	103	104	105	106	
Y	R	—	—	N	N	N	BG	—	B	O	RG	W	RW
68	69	70	71	72	73	74	75	76	77	78	79	80	
N	G	UY	U	—	—	U	R	Y	—	Y	Y	GR	GW
42	43	44	45	46	47	48	49	50	51	52	53	54	
—	BG	GW	BK	BK	WG	YG	—	WU	WU	GR	YR	B	
15	16	17	18	19	20	21	22	23	24	25	26	27	28
—	—	B	B	B	BG	BG	—	NR	WG	WG	—	WR	—

107	108	109	110	111	112	113	114	115	116	117	118	119	120
G	N	Y	YU	B	UY	BG	BK	BR	B	RW	U	BO	BG
81	82	83	84	85	86	87	88	89	90	91	92	93	
B	B	R	Y	—	—	GU	Y	YR	GR	B	UY	RW	
55	56	57	58	59	60	61	62	63	64	65	66	67	
RW	RW	YU	YG	YR	YU	GW	GW	GR	YR	—	UY	O	
29	30	31	32	33	34	35	36	37	38	39	40	41	
B	B	GR	—	WG	BG	—	O	B	OY	OG	BW	GO	
1	2	3	4	5	6	7	8	9	10	11	12	13	14
RU	RU	—	B	B	Y	GO	GO	U	GU	—	OY	—	—

V8 SC

121	122	123	124	125	126	127	128	129	130	131	132	133	134
WU	—	G	Y	—	—	BK	N	N	BW	GB	YB	—	GU
94	95	96	97	98	99	100	101	102	103	104	105	106	
Y	R	—	—	N	N	N	BG	—	B	O	RG	W	RW
68	69	70	71	72	73	74	75	76	77	78	79	80	
N	G	UY	U	YU	—	—	R	Y	—	Y	Y	GR	GW
42	43	44	45	46	47	48	49	50	51	52	53	54	
—	BG	GW	BK	BK	WG	YG	—	WU	WU	GR	YR	B	
15	16	17	18	19	20	21	22	23	24	25	26	27	28
—	—	B	B	B	BG	BG	—	NR	WG	WG	—	WR	—



DYNAMIC STABILITY CONTROL CONTROL MODULE

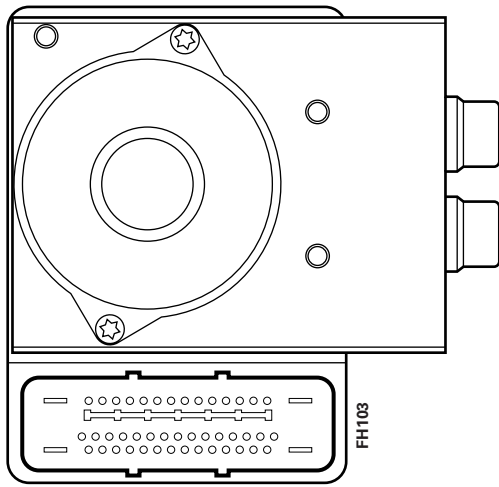

FH103 / BLACK

1	R	2	—	3	G	4	WG	5	B	6	Y	7	R	8	UV	9	U	10	—	11	Y	12	YR	13	Y	14	G	15	G	16	B																														
17	WR	18	YB	19	NW	20	WB	21	—	22	—	23	—	24	WB	25	U	26	WR	27	WG	28	NG	29	Y	30	YR	31	NR	32	RW	33	YR	34	WR	35	—	36	N	37	B	38	RU	39	—	40	W	41	—	42	B	43	N	44	—	45	W	46	Y	47	B

TOP

ADAPTIVE SPEED CONTROL CONTROL MODULE

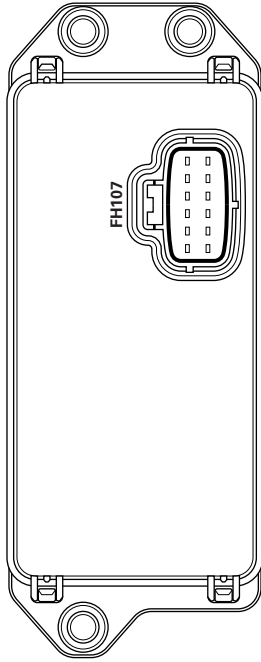

FH107 / BLACK

1	NR	2	B	3	—	4	G	5	—	6	G
7	NW	8	—	9	—	10	Y	11	—	12	GW

ADAPTIVE DAMPING CONTROL MODULE

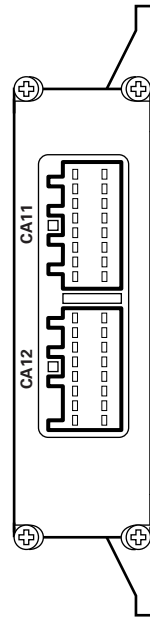

CA12 / GREY

1	—	2	—	3	—	4	—	5	—	6	—	7	—	8	—
9	Y	10	YB	11	WB	12	YR	13	—	14	—	15	—	16	—

CA11 / BLUE

1	WB	2	BG	3	W	4	BO	5	BW	6	WG	7	BG	8	WU
9	N	10	B	11	—	12	NG	13	U	14	Y	15	—	16	NW

ELECTRONIC PARKING BRAKE CONTROL MODULE

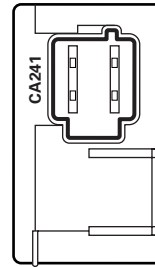

CA241 / BLACK

1	NR	2	GW
3	—	4	—
5	—	6	—
7	—	8	—

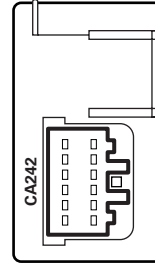

CA242 / BLACK

12	W	11	R	10	Y	9	GB	8	YR	7	U
6	G	5	U	4	YB	3	YG	2	—	1	Y



AIR CONDITIONING CONTROL MODULE – PANEL

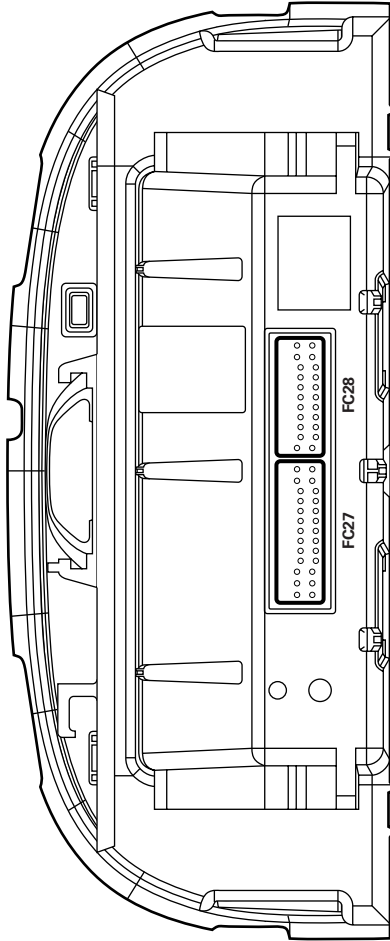

FC27 / GREY

13	WB
12	YR
11	WR
10	YR
9	WR
8	YR
7	WR
6	YR
5	WR
4	WB
3	WR
2	WB
1	WB
23	YU
22	WU
21	WU
20	NR
19	NR
18	NR
17	NR
16	NR
15	NR
14	NR

FC28 / GREY

11	N
10	WR
9	WU
8	WR
7	WR
6	WR
5	NR
4	NR
3	NR
2	B
1	G
22	Y
21	—
20	—
19	—
18	—
17	—
16	—
15	—
14	—
13	—
12	—
11	—

* LHD – WB; RHD – WG
 ** LHD – WG; RHD – WB

AIR CONDITIONING CONTROL MODULE – REMOTE

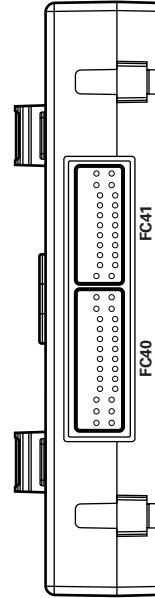

FC40 / GREY

13	WB
12	YR
11	WR
10	YR
9	WR
8	YR
7	WR
6	YR
5	WR
4	WB
3	WR
2	WB
1	WB
23	YU
22	WU
21	WU
20	NR
19	NR
18	NR
17	NR
16	NR
15	NR
14	NR

FC41 / GREY

11	N
10	WR
9	WU
8	WR
7	WR
6	WR
5	NR
4	NR
3	NR
2	B
1	G
22	Y
21	—
20	—
19	—
18	—
17	—
16	—
15	—
14	—
13	—
12	—
11	—

* LHD – WB; RHD – WG
 ** LHD – WG; RHD – WB



GENERAL ELECTRONIC CONTROL MODULE

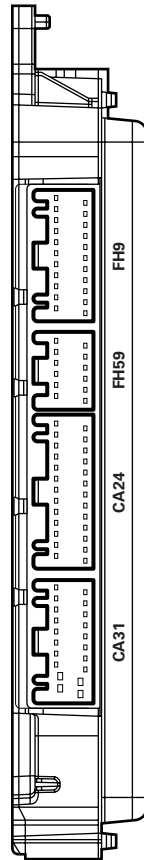

CA31 / BLACK

1	W
2	LWR
3	WU
4	—
5	N
6	—
7	BG
8	BW
9	—
10	—
11	O
12	O
13	GW
14	Y
15	—
16	G
17	—
18	N
19	—
20	NW

CA24 / NATURAL

1	—
2	—
3	—
4	WG
5	LW
6	—
7	LWR
8	YR
9	—
10	—
11	YR
12	Y
13	—
14	—
15	BG
16	—
17	—
18	O
19	—
20	UY
21	RW
22	NR
23	WB
24	YB
25	—
26	U

FH59 / BLACK

1	U
2	BG
3	LW
4	NR
5	BG
6	NG
7	Y
8	NR
9	BG
10	BR
11	—
12	B

FH9 / BLACK

1	NW
2	—
3	NG
4	—
5	—
6	BW
7	BG
8	R
9	—
10	—
11	BW
12	—
13	BG
14	BW
15	WU
16	Y
17	Y
18	—
19	BO
20	—
21	BO
22	BO

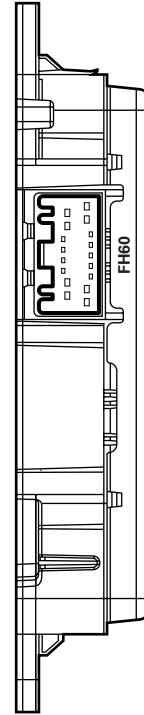

FH60 / BLACK

1	—
2	NG
3	WG
4	BW
5	BW
6	L
7	BW
8	BR
9	WG
10	BR
11	B
12	—
13	B
14	B
15	B
16	YB
17	BG



REAR ELECTRONIC CONTROL MODULE

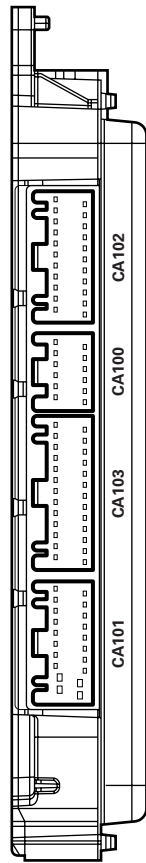

CA101 / BLACK

1	2	3	4	5	6	7	8	9	10
GR	B	N	BO	N	—	—	—	—	—
11	12	13	14	15	16	17	18	19	20
R	Y	—	—	WR	WU	*	BO	BG	—

* LHD - BG; RHD - BO

CA103 / NATURAL

1	2	3	4	5	6	7	8	9	10	11	12	13
—	—	—	YG	Y	W	WE	YU	YU	O	B	B	N
14	15	16	17	18	19	20	21	22	23	24	25	26
—	—	**	—	—	—	—	—	—	NR	—	B	B

** LHD - BO; RHD - BG

CA100 / BLACK

1	2	3	4	5	6
YG	—	—	—	BG	BR
7	8	9	10	11	12
—	—	—	GU	BR	BG

CA102 / BLACK

1	2	3	4	5	6	7	8	9	10	11
Y	Y	—	WU	—	—	NW	—	—	—	—
12	13	14	15	16	17	18	19	20	21	22
B	GO	WB	—	—	—	—	—	—	—	—

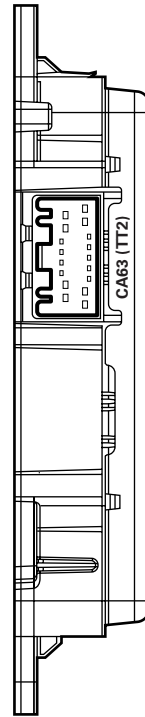

CA63 (TT2) / BLACK

1	2	3	4	5	6	7	8	
BG	BO	BW	BG	BO	BW	BG	BW	
9	10	11	12	13	14	15	16	17
BG	BR	—	—	—	—	—	—	Y



INSTRUMENT PACK

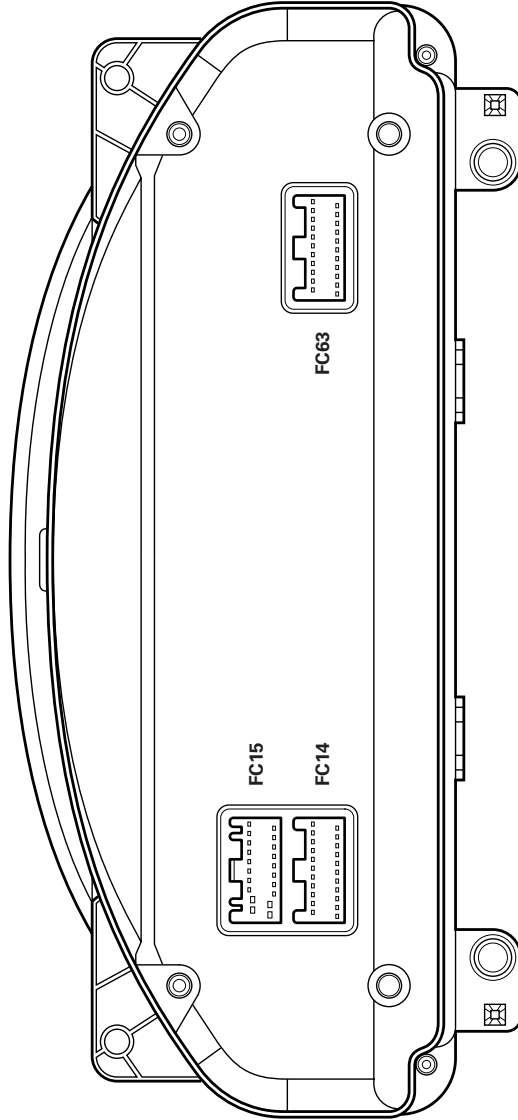

FC15 / BLACK

1	NR	2	B	3	NG	4	BG	5	WR	6	YR	7	—	8	Y	9	G	10	U
11	Y	12	N	13	G	14	Y	15	—	16	—	17	—	18	Y	19	L	20	Y

FC14 / GREY

1	BG	2	WU	3	WG	4	W	5	O	6	—	7	Y	8	WB	9	BO	10	GW	11	GB
12	WG	13	YR	14	B	15	—	16	—	17	—	18	—	19	—	20	—	21	WR	22	O

FC63 / BLACK

1	UY	2	OY	3	UY	4	GR	5	GW	6	*	7	BW	8	U	9	W	10	NG	11	—
12	O	13	U	14	OG	15	GO	16	GU	17	W	18	N	19	R	20	U	21	WU	22	—

* LHD - GU; RHD - WB



DRIVER SEAT CONTROL MODULE

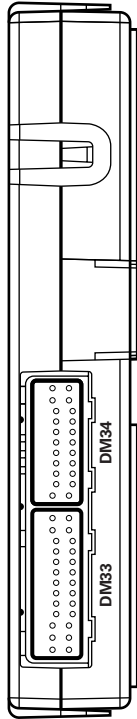

DM33 / BLACK

13	NG	Y	WB
26	B	WB	—

9	WU	—	—
10	R	U	—
22	WR	—	—
23	WR	WU	—
24	—	—	—
25	—	—	—
26	—	—	—

DM34 / BLACK

11	GB	—	—
22	WR	—	—
23	WR	—	—
24	—	—	—
25	—	—	—
26	—	—	—

DM35 / BLACK

6	NR	—	—
5	B	—	—
4	—	—	—
3	—	—	—
2	OG	—	—

DM36 / BLACK

4	RU	—	—
3	RU	—	—
2	WU	—	—
1	UY	—	—

DM37 / BLACK

4	U	—	—
3	GU	—	—
2	—	—	—
1	—	—	—

DM38 / BLACK

6	GR	GO	NW
5	RG	GW	B
4	—	—	—
3	—	—	—
2	—	—	—

DRIVER DOOR CONTROL MODULE

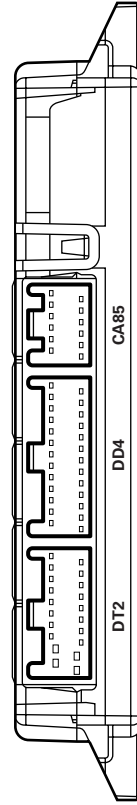

DT2 / BLACK

1	WR	—	—
2	L	YR	—
3	OY	—	—
4	U	—	—
5	YB	—	—
6	Y	—	—
7	—	—	—
8	YB	—	—
9	WU	—	—
10	—	—	—
11	—	—	—
12	—	—	—
13	W	—	—
14	WB	—	—
15	YB	—	—
16	BG	—	—
17	BSW	—	—
18	GW	—	—
19	NW	—	—
20	—	—	—

DD4 / NATURAL

1	YR	—	—
2	—	—	—
3	UY	—	—
4	—	—	—
5	—	—	—
6	—	—	—
7	Y	—	—
8	—	—	—
9	YR	—	—
10	—	—	—
11	YU	—	—
12	—	—	—
13	—	—	—
14	—	—	—
15	—	—	—
16	—	—	—
17	—	—	—
18	NWB	—	—
19	—	—	—
20	Y	—	—
21	G	—	—
22	—	—	—
23	WR	—	—
24	OY	—	—
25	Y	—	—
26	Y	—	—

CA85 / BLACK

1	—	—	—
2	BG	—	—
3	Y	—	—
4	U	—	—
5	WG	—	—
6	Y	—	—
7	B	—	—
8	B	—	—
9	BO	—	—
10	BO	—	—
11	WG	—	—
12	NR	—	—

Fig. 01.1

COMPONENTS

Component	Connector(s)	Connector Description	Location
BATTERY	—	—	LUGGAGE COMPARTMENT
FRONT POWER DISTRIBUTION FUSE BOX	—	—	ENGINE COMPARTMENT, RH SIDE
IGNITION SWITCH	FC18	7-WAY / BLACK	STEERING COLUMN COWLING
REAR POWER DISTRIBUTION FUSE BOX MEGAFUSE	—	—	LUGGAGE COMPARTMENT
REAR POWER DISTRIBUTION FUSE BOX	—	—	LUGGAGE COMPARTMENT
STARTER MEGAFUSE	—	—	LUGGAGE COMPARTMENT
TRANSIT ISOLATION RELAY	CA16 JB2	2-WAY / WHITE NOT AVAILABLE	LUGGAGE COMPARTMENT, BATTERY + POST

HARNESS IN-LINE CONNECTORS

Connector	Connector Description / Location	Location
FC39	10-WAY / GREY / CABIN HARNESS TO FASCIA HARNESS	BEHIND INSTRUMENT PANEL, RH SIDE

GROUNDS

Ground	Location
JB1	LUGGAGE COMPARTMENT, BATTERY GROUND

Refer to the front of this book for detailed information and illustrations regarding the location and identification of harnesses, relays, fuses, grounds, control modules and control module pins.

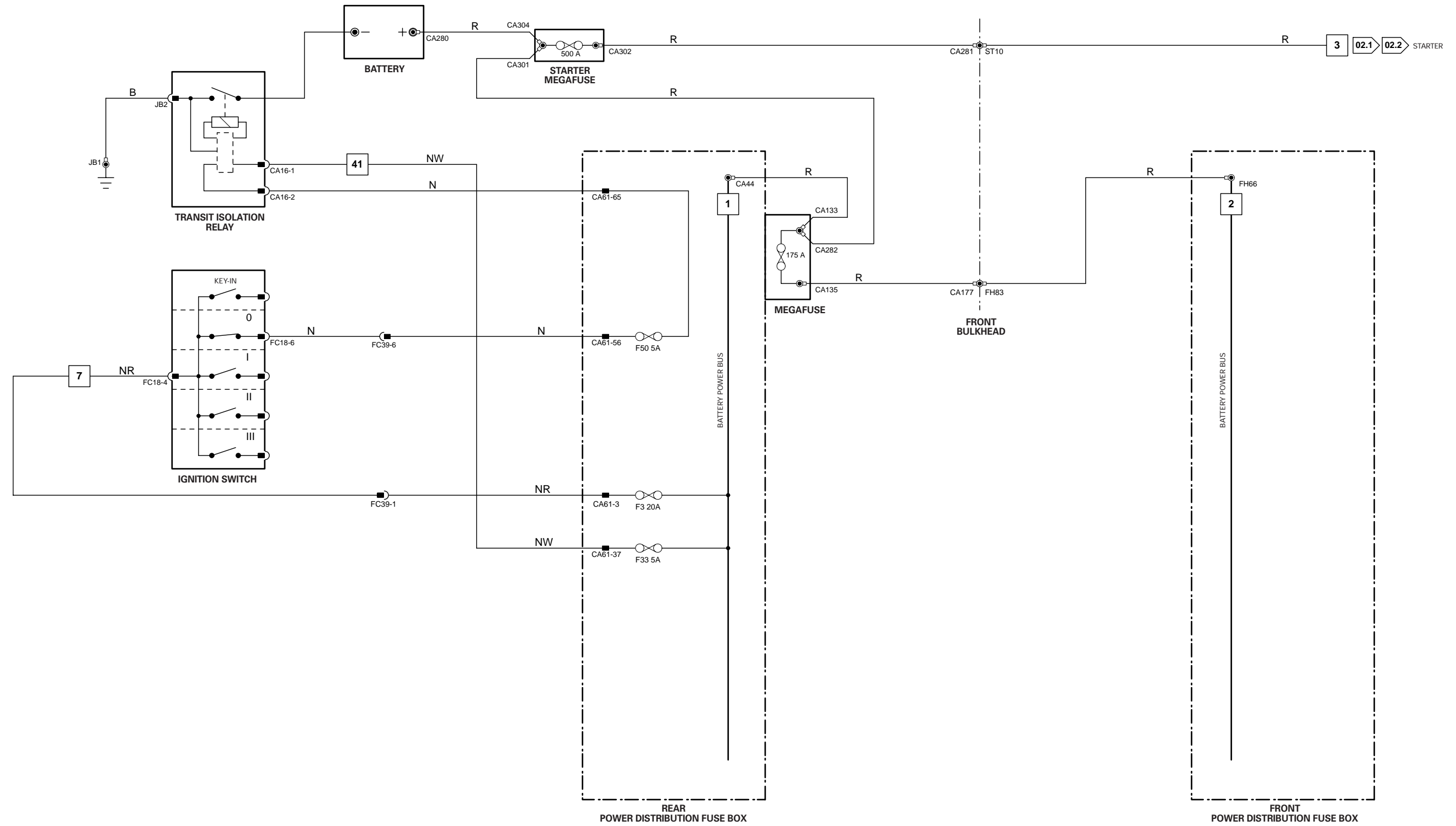

Fig. 01.2**COMPONENTS**

Component	Connector(s)	Connector Description	Location
FRONT POWER DISTRIBUTION FUSE BOX	—	—	ENGINE COMPARTMENT, RH SIDE
REAR POWER DISTRIBUTION FUSE BOX	—	—	LUGGAGE COMPARTMENT

HARNESS IN-LINE CONNECTORS

Connector	Connector Description / Location	Location
CA3A/B	14-WAY / GREY / CABIN HARNESS BRIDGE	LUGGAGE COMPARTMENT, LH REAR
CP1	10-WAY / BLACK / INTERCOOLER PUMP LINK LEAD	ENGINE COMPARTMENT, RH FRONT, ADJACENT TO RADIATOR
DM22	4-WAY / GREY / CABIN HARNESS TO DRIVER SEAT HARNESS	UNDER DRIVER SEAT
DM23	20-WAY / BLACK / CABIN HARNESS TO DRIVER SEAT HARNESS	UNDER DRIVER SEAT
DT8	14-WAY / GREY / CABIN HARNESS TO DRIVER DOOR TRIM HARNESS	DRIVER DOOR
FC39	10-WAY / GREY / CABIN HARNESS TO FASCIA HARNESS	BEHIND INSTRUMENT PANEL, RH SIDE
FH1	20-WAY / BLACK / CABIN HARNESS TO FRONT HARNESS	RH 'A' POST, LOWER
PI41	42-WAY / BLACK / ENGINE HARNESS TO VEHICLE HARNESSES	ENGINE COMPARTMENT, BULKHEAD, PASSENGER SIDE
PI42	8-WAY / BLACK / ENGINE HARNESS TO FRONT HARNESS	ENGINE COMPARTMENT, BULKHEAD, PASSENGER SIDE
PN23	4-WAY / GREY / CABIN HARNESS TO PASSENGER SEAT HARNESS	UNDER PASSENGER SEAT
PN24	20-WAY / BLACK / CABIN HARNESS TO PASSENGER SEAT HARNESS	UNDER PASSENGER SEAT
PT1	14-WAY / GREY / CABIN HARNESS TO PASSENGER DOOR TRIM HARNESS	PASSENGER DOOR

Refer to the front of this book for detailed information and illustrations regarding the location and identification of harnesses, relays, fuses, grounds, control modules and control module pins.

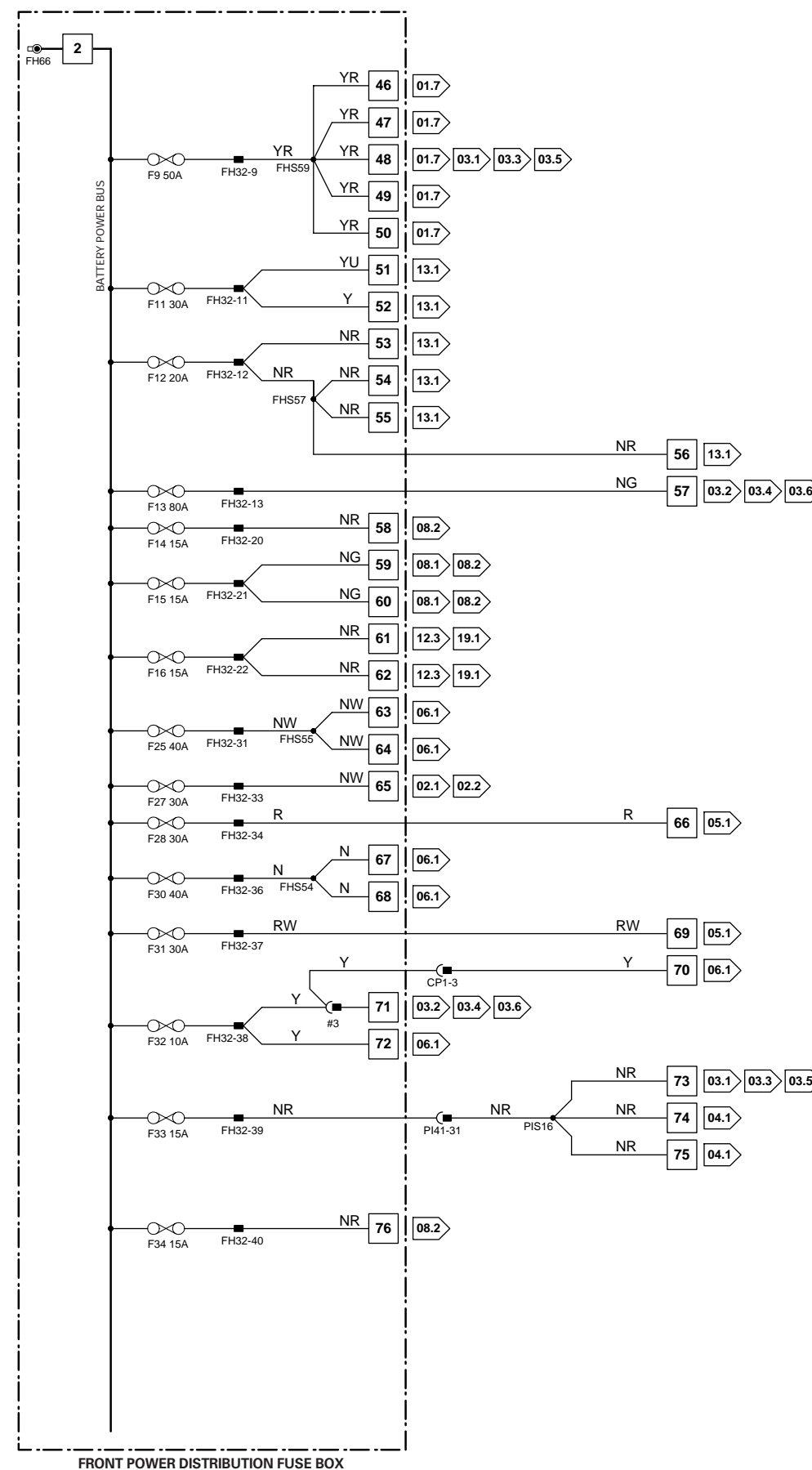
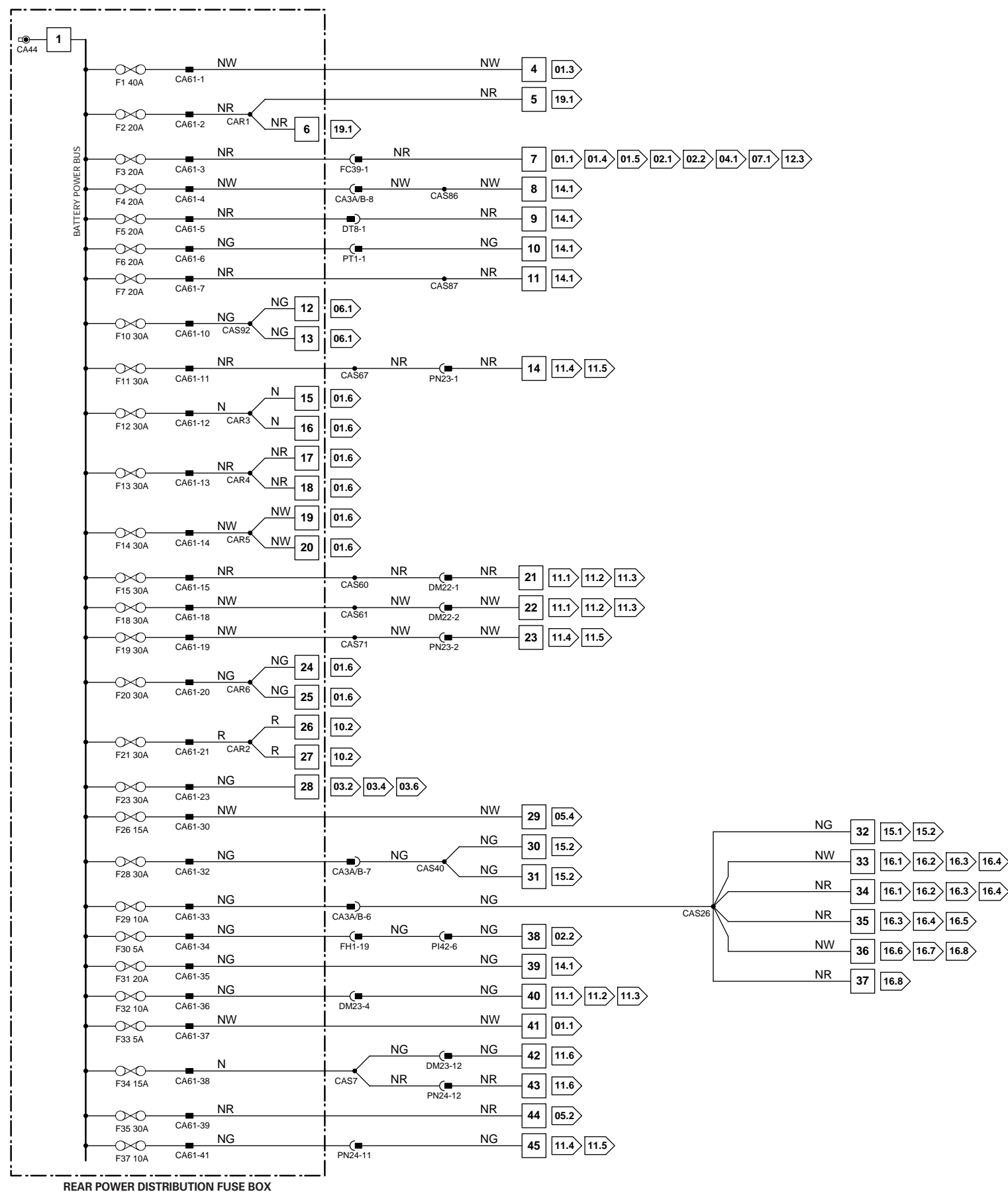

1 → 3
Fig. 01.1

4 → 76
Fig. 01.2

77 → 92
Fig. 01.3

1 → 14
Fig. 01.4

15 → 45
Fig. 01.5

46 → 80
Fig. 01.6

81 → 118
Fig. 01.7

I Input
O Output

B Battery Voltage
P Power Ground

+ Sensor/Signal Supply V
- Sensor/Signal Ground

C CAN
S SCP
D D2B Network
D Serial and Encoded Data

VARIANT: All Vehicles
VIN RANGE: All
DATE OF ISSUE: June 2002

Fig. 01.3**COMPONENTS**

Component	Connector(s)	Connector Description	Location
PRIMARY JUNCTION FUSE BOX	CA2 CA56 FC37 FH7 FH53	26-WAY / BLACK 8-WAY / BLACK 26-WAY / BLACK 6-WAY / BLACK 10-WAY / BLACK	RH 'A' POST
REAR POWER DISTRIBUTION FUSE BOX	—	—	LUGGAGE COMPARTMENT

HARNESS IN-LINE CONNECTORS

Connector	Connector Description / Location	Location
FH1	20-WAY / BLACK / CABIN HARNESS TO FRONT HARNESS	RH 'A' POST, LOWER
SL3	10-WAY / GREY / FASCIA HARNESS TO SOLAR SENSOR LINK	BEHIND INSTRUMENT PANEL, RH SIDE

Refer to the front of this book for detailed information and illustrations regarding the location and identification of harnesses, relays, fuses, grounds, control modules and control module pins.

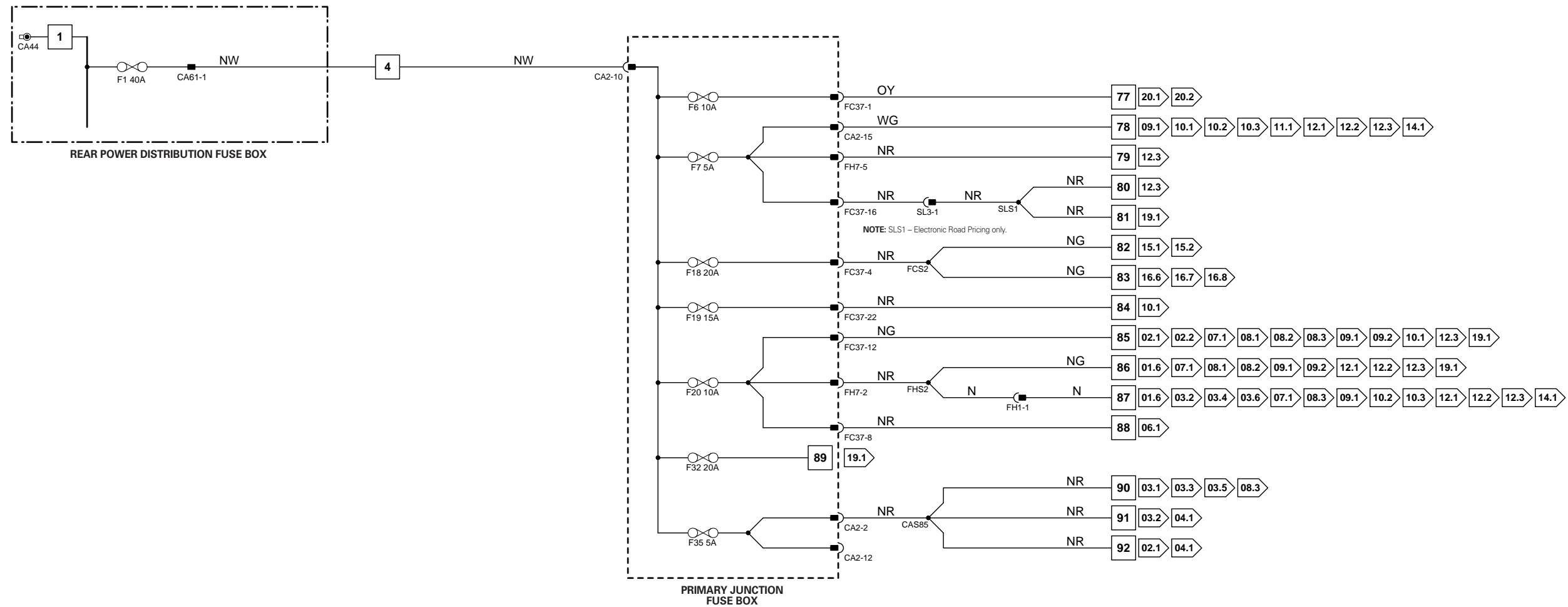

1 → 3
Fig. 01.1

4 → 76
Fig. 01.2

77 → 92
Fig. 01.3

1 → 14
Fig. 01.4

15 → 45
Fig. 01.5

46 → 80
Fig. 01.6

81 → 118
Fig. 01.7

I Input
O Output

B/V Battery Voltage
P/ Power Ground

+ Sensor/Signal Supply V
- Sensor/Signal Ground

C CAN
S SCP
D D2B Network
D Serial and Encoded Data

VARIANT: All Vehicles
VIN RANGE: All
DATE OF ISSUE: June 2002

Fig. 01.4

COMPONENTS

Component	Connector(s)	Connector Description	Location
IGNITION SWITCH	FC18	7-WAY / BLACK	STEERING COLUMN COWLING
PRIMARY JUNCTION FUSE BOX	CA2	26-WAY / BLACK	RH 'A' POST
	CA56	8-WAY / BLACK	
	FC37	26-WAY / BLACK	
	FH7	6-WAY / BLACK	
	FH53	10-WAY / BLACK	
REAR POWER DISTRIBUTION FUSE BOX	—	—	LUGGAGE COMPARTMENT

HARNESS IN-LINE CONNECTORS

Connector	Connector Description / Location	Location
FC10	14-WAY / GREEN / FASCIA HARNESS TO FRONT HARNESS	BEHIND INSTRUMENT PANEL, RH SIDE
FC39	10-WAY / GREY / CABIN HARNESS TO FASCIA HARNESS	BEHIND INSTRUMENT PANEL, RH SIDE

Refer to the front of this book for detailed information and illustrations regarding the location and identification of harnesses, relays, fuses, grounds, control modules and control module pins.

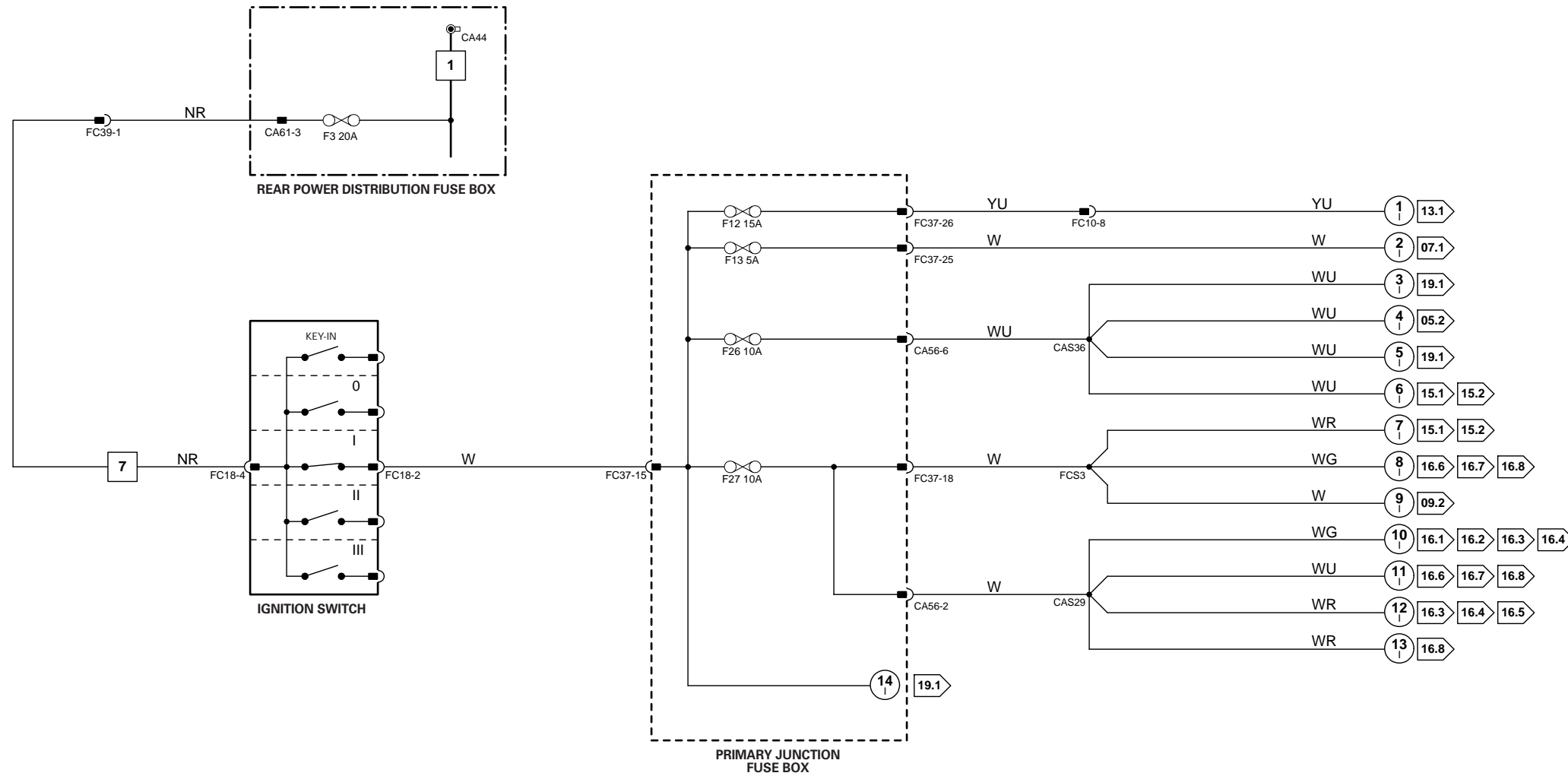

1 → 3
Fig. 01.1

4 → 76
Fig. 01.2

77 → 92
Fig. 01.3

1 → 14
Fig. 01.4

15 → 45
Fig. 01.5

46 → 80
Fig. 01.6

81 → 118
Fig. 01.7

I Input
O Output

B Battery Voltage
P Power Ground

+ Sensor/Signal Supply V
- Sensor/Signal Ground

C CAN
S SCP
D D2B Network
D Serial and Encoded Data

VARIANT: All Vehicles
VIN RANGE: All
DATE OF ISSUE: June 2002

Fig. 01.5**COMPONENTS**

Component	Connector(s)	Connector Description	Location
FRONT POWER DISTRIBUTION FUSE BOX	—	—	ENGINE COMPARTMENT, RH SIDE
IGNITION SWITCH	FC18	7-WAY / BLACK	STEERING COLUMN COWLING
INERTIA SWITCH	CA4	3-WAY / GREY	LH 'A' POST
PRIMARY JUNCTION FUSE BOX	CA2	26-WAY / BLACK	RH 'A' POST
	CA56	8-WAY / BLACK	
	FC37	26-WAY / BLACK	
	FH7	6-WAY / BLACK	
	FH53	10-WAY / BLACK	
REAR POWER DISTRIBUTION FUSE BOX	—	—	LUGGAGE COMPARTMENT

HARNESS IN-LINE CONNECTORS

Connector	Connector Description / Location	Location
DM23	20-WAY / BLACK / CABIN HARNESS TO DRIVER SEAT HARNESS	UNDER DRIVER SEAT
FC10	14-WAY / GREEN / FASCIA HARNESS TO FRONT HARNESS	BEHIND INSTRUMENT PANEL, RH SIDE
FC39	10-WAY / GREY / CABIN HARNESS TO FASCIA HARNESS	BEHIND INSTRUMENT PANEL, RH SIDE
FH1	20-WAY / BLACK / CABIN HARNESS TO FRONT HARNESS	RH 'A' POST, LOWER
GB1	16-WAY / GREY / ENGINE HARNESS TO TRANSMISSION HARNESS	ADJACENT TO TRANSMISSION BELL HOUSING
PI41	42-WAY / BLACK / ENGINE HARNESS TO VEHICLE HARNESSES	ENGINE COMPARTMENT, BULKHEAD, PASSENGER SIDE
PN24	20-WAY / BLACK / CABIN HARNESS TO PASSENGER SEAT HARNESS	UNDER PASSENGER SEAT
RF34	16-WAY / GREEN / CABIN HARNESS TO DOOR HARNESS	'D' POST, UNDER PARCEL SHELF

Refer to the front of this book for detailed information and illustrations regarding the location and identification of harnesses, relays, fuses, grounds, control modules and control module pins.

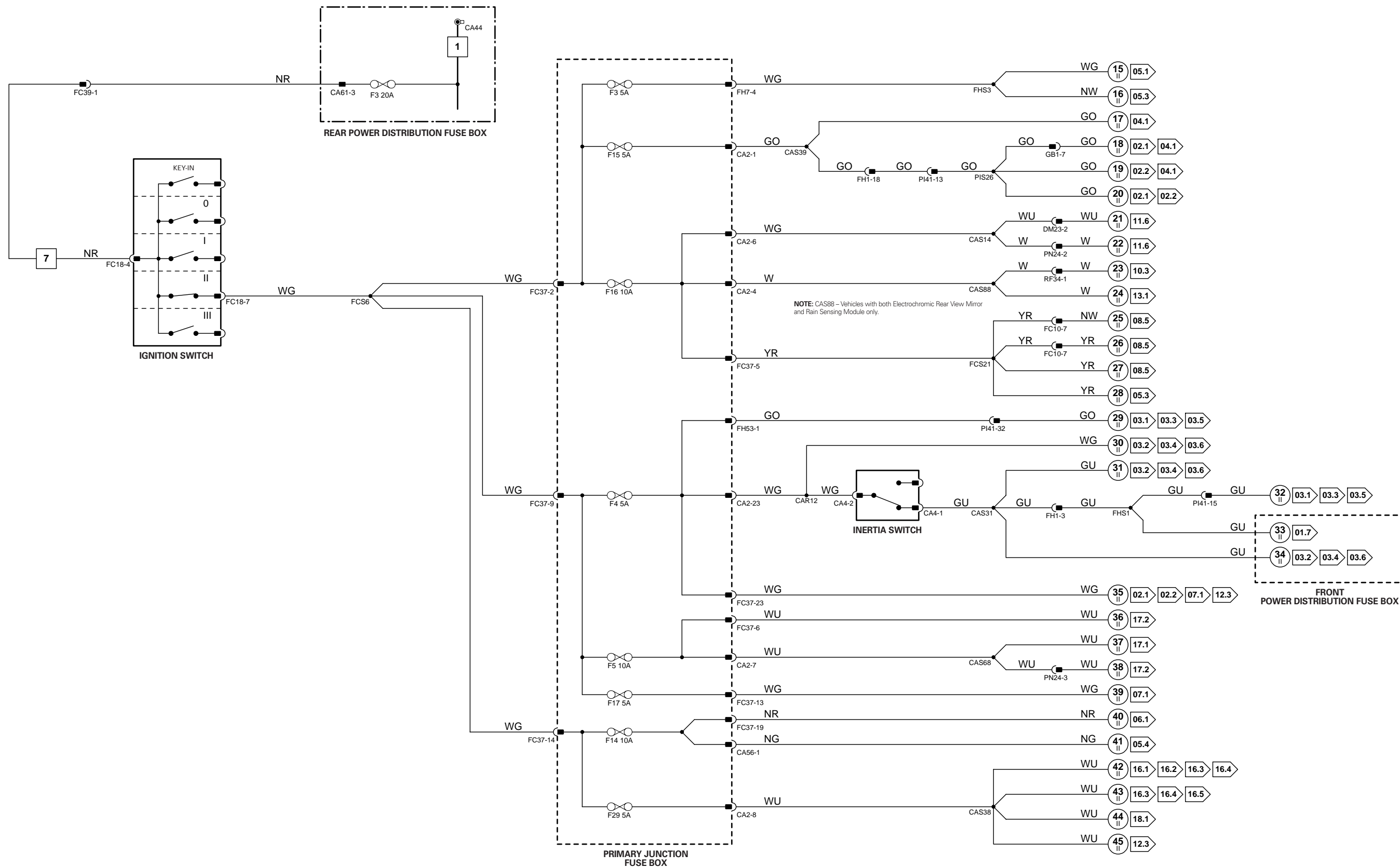

CONTROL MODULE PIN-OUT INFORMATION

General Electronic Control Module

Pin	Description and Characteristic
O FH9-21	SWITCHED SYSTEM POWER RELAYS ACTIVATE: TO ACTIVATE, GECM SWITCHES CIRCUIT TO GROUND
S FH59-1	SCP -
B+ FH59-6	BATTERY POWER SUPPLY (LOGIC): B+
S FH59-7	SCP +
PG FH60-11	POWER GROUND: GROUND

Rear Electronic Control Module

Pin	Description and Characteristic
B+ CA101-3	BATTERY POWER SUPPLY: B+
O CA101-4	SWITCHED SYSTEM POWER RELAYS ACTIVATE: TO ACTIVATE, RECM SWITCHES CIRCUIT TO GROUND
S CA102-1	SCP +
S CA102-2	SCP -
PG CA102-12	POWER GROUND: GROUND

NOTE: Refer to the Appendix at the rear of this book for Network Messages.

Fig. 01.6

COMPONENTS

Component	Connector(s)	Connector Description	Location
GENERAL ELECTRONIC CONTROL MODULE	FH9 CA24 CA31 FH59 FH60	22-WAY / BLACK 26-WAY / NATURAL 20-WAY / BLACK 12-WAY / BLACK 17-WAY / BLACK	LH 'A' POST
PRIMARY JUNCTION FUSE BOX	CA2 CA56 FC37 FH7 FH53	26-WAY / BLACK 8-WAY / BLACK 26-WAY / BLACK 6-WAY / BLACK 10-WAY / BLACK	RH 'A' POST
REAR ELECTRONIC CONTROL MODULE	CA63 CA100 CA101 CA102 CA103	17-WAY / BLACK 12-WAY / BLACK 20-WAY / BLACK 22-WAY / BLACK 26-WAY / NATURAL	LUGGAGE COMPARTMENT, RH REAR
REAR POWER DISTRIBUTION FUSE BOX	—	—	LUGGAGE COMPARTMENT
SWITCHED SYSTEM POWER RELAY 1	—	—	REAR POWER DISTRIBUTION FUSE BOX – R2
SWITCHED SYSTEM POWER RELAY 2	—	—	REAR POWER DISTRIBUTION FUSE BOX – R11
SWITCHED SYSTEM POWER RELAY 3	—	—	REAR POWER DISTRIBUTION FUSE BOX – R4
SWITCHED SYSTEM POWER RELAY 4	—	—	REAR POWER DISTRIBUTION FUSE BOX – R5

HARNESS IN-LINE CONNECTORS

Connector	Connector Description / Location	Location
BF1	6-WAY / GREY / FRONT HARNESS TO FRONT BUMPER HARNESS	BEHIND FRONT BUMPER, LH SIDE
BR1	10-WAY / GREY / CABIN HARNESS TO REAR BUMPER HARNESS	BEHIND REAR BUMPER, RH SIDE
CA3A/B	14-WAY / GREY / CABIN HARNESS BRIDGE	LUGGAGE COMPARTMENT, LH REAR
FC33	16-WAY / GREEN / CABIN HARNESS TO FASCIA HARNESS	BEHIND INSTRUMENT PANEL, RH SIDE
FH1	20-WAY / BLACK / CABIN HARNESS TO FRONT HARNESS	RH 'A' POST, LOWER
FH39	12-WAY / GREY / FRONT HARNESS TO RH FRONT HEADLAMP LINK	BEHIND FRONT BUMPER, RH SIDE
FH40	12-WAY / GREY / FRONT HARNESS TO LH FRONT HEADLAMP LINK	BEHIND FRONT BUMPER, LH SIDE
FH6	16-WAY GREEN / CABIN HARNESS TO FRONT HARNESS	LH 'A' POST, ADJACENT TO GECM
RF34	16-WAY / GREEN / CABIN HARNESS TO DOOR HARNESS	'D' POST, UNDER PARCEL SHELF
TT1	6-WAY / GREY / TRAILER TOWING IN-LINE CONNECTOR	LUGGAGE COMPARTMENT, ADJACENT TO RH TAIL LAMP

GROUNDS

Ground	Location
CA156	LUGGAGE COMPARTMENT, RH SIDE
FH77	LH LOWER 'A' POST, ADJACENT TO THE GENERAL ELECTRONIC CONTROL MODULE (FORWARD OF CA30)

FOR CONTROL MODULE PIN-OUT INFORMATION, UNFOLD PAGE TO LEFT.

The following abbreviations are used to represent values for Control Module Pin-Out data

I	Input	PG	Power Ground	C	CAN Network	D	Serial and Encoded Data
O	Output	SS	Sensor / Signal Supply V	S	SCP Network	V	Voltage (DC)
B+	Battery Voltage	SG	Sensor / Signal Ground	D2	D2B Network	PWM	Pulse Width Modulated

CAUTION: The information on this data page is furnished to aid the user in understanding circuit operation. THIS INFORMATION SHOULD BE USED FOR REFERENCE ONLY.

NOTE: The values listed are approximately those that can be expected at the control module connector pins with all circuit connections made and all components connected and fitted.

Refer to the front of this book for detailed information and illustrations regarding the location and identification of harnesses, relays, fuses, grounds, control modules and control module pins.



SCP NOTE: The switched system power relays are activated by the GECM or the RECM whenever messages are present on the SCP network. After the ignition is switched off, the relays remain activated until all SCP messages are removed.

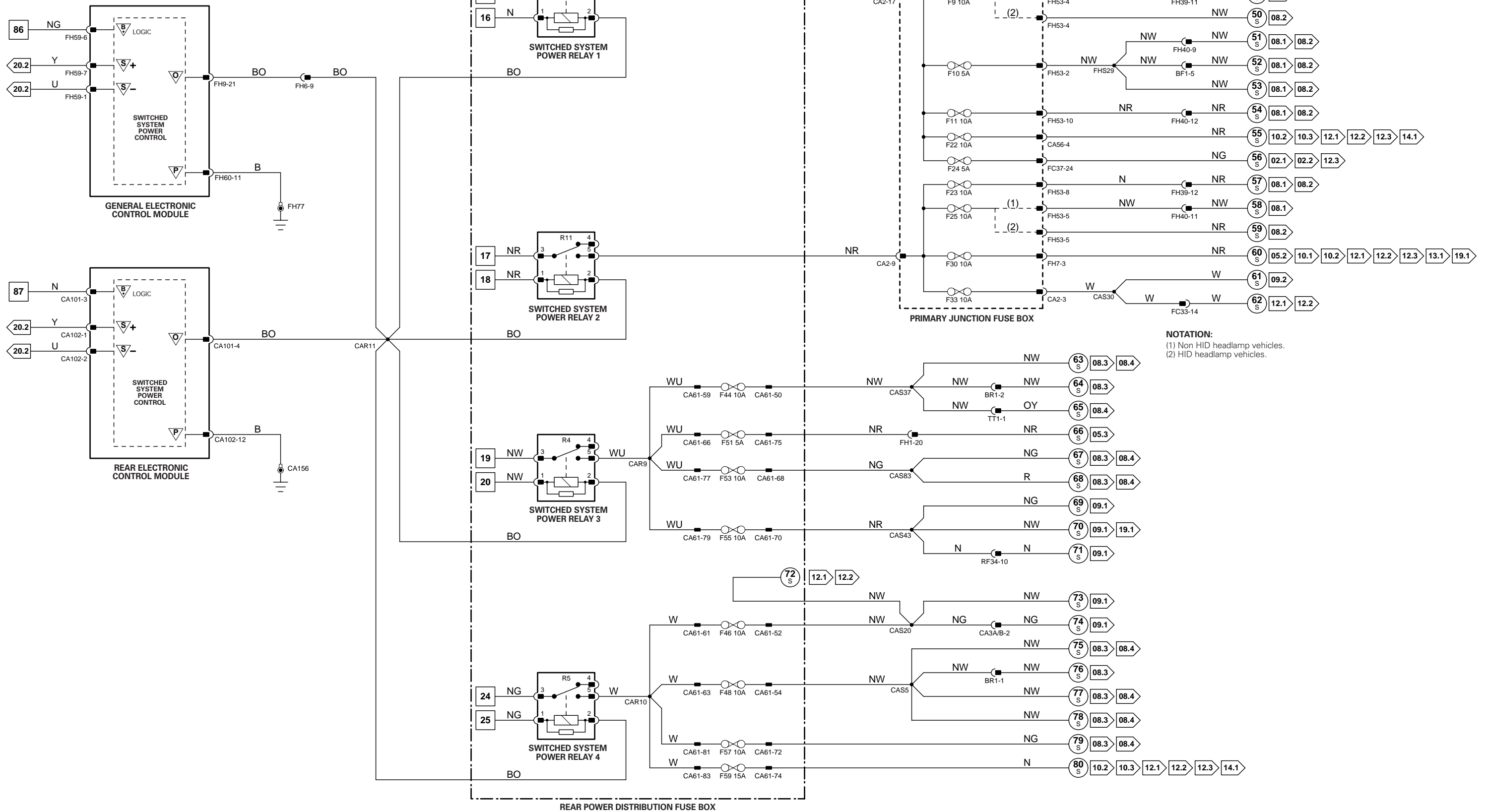

NOTATION:
(1) Non HID headlamp vehicles.
(2) HID headlamp vehicles.

CONTROL MODULE PIN-OUT INFORMATION

Engine Control Module

Pin	Description and Characteristic
O P11-40	EMS CONTROL RELAY DRIVE: TO ACTIVATE, ECM SWITCHES CIRCUIT TO GROUND

Fig. 01.7

COMPONENTS

Component	Connector(s)	Connector Description	Location
EMS CONTROL RELAY	—	—	FRONT POWER DISTRIBUTION FUSE BOX – R5
ENGINE CONTROL MODULE	PI1	134-WAY / BLACK	FRONT BULKHEAD, PASSENGER SIDE
FRONT POWER DISTRIBUTION FUSE BOX	—	—	ENGINE COMPARTMENT, RH SIDE
H02S RELAY	—	—	FRONT POWER DISTRIBUTION FUSE BOX – R2
IGNITION COIL RELAY	—	—	FRONT POWER DISTRIBUTION FUSE BOX – R3

HARNES IN-LINE CONNECTORS

Connector	Connector Description / Location	Location
CP1	10-WAY / BLACK / INTERCOOLER PUMP LINK LEAD	ENGINE COMPARTMENT, RH FRONT, ADJACENT TO RADIATOR
FH1	20-WAY / BLACK / CABIN HARNES TO FRONT HARNES	RH 'A' POST, LOWER
IL10	12-WAY / BLACK / ENGINE HARNES TO FUEL INJECTOR LINK	REAR OF ENGINE
IS5	6-WAY / BLACK / ENGINE HARNES TO FUEL INJECTOR LINK	ENGINE, LH REAR
IS6	6-WAY / BLACK / ENGINE HARNES TO FUEL INJECTOR LINK	ENGINE, RH REAR
PI41	42-WAY / BLACK / ENGINE HARNES TO VEHICLE HARNESSES	ENGINE COMPARTMENT, BULKHEAD, PASSENGER SIDE

GROUNDS

Ground	Location
FH42	ENGINE COMPARTMENT, BEHIND RH HEADLAMP

FOR CONTROL MODULE PIN-OUT INFORMATION, UNFOLD PAGE TO LEFT.

The following abbreviations are used to represent values for Control Module Pin-Out data

I	Input	PG	Power Ground	C	CAN Network	D	Serial and Encoded Data
O	Output	SS	Sensor / Signal Supply V	S	SCP Network	V	Voltage (DC)
B+	Battery Voltage	SG	Sensor / Signal Ground	D2	D2B Network	PWM	Pulse Width Modulated

CAUTION: The information on this data page is furnished to aid the user in understanding circuit operation. THIS INFORMATION SHOULD BE USED FOR REFERENCE ONLY.

NOTE: The values listed are approximately those that can be expected at the control module connector pins with all circuit connections made and all components connected and fitted.

Refer to the front of this book for detailed information and illustrations regarding the location and identification of harnesses, relays, fuses, grounds, control modules and control module pins.

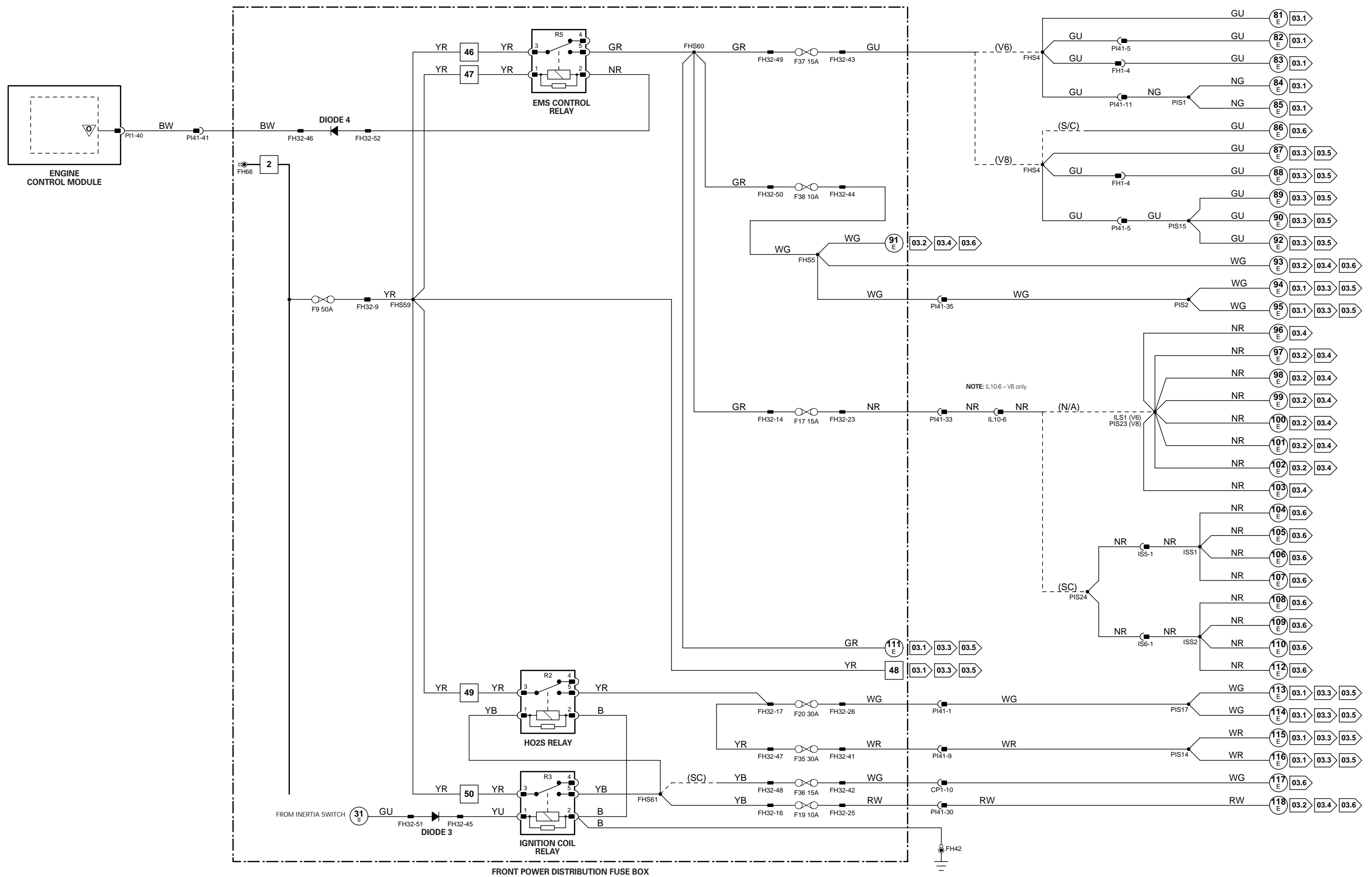

NOTE: IL10-6 - V6 only.

CONTROL MODULE PIN-OUT INFORMATION

Engine Control Module

Pin	Description and Characteristic
I P11-6	ENGINE CRANK: B+
I P11-31	AUTOMATIC - PARK / NEUTRAL SIGNAL: B+ WHEN ACTIVATED MANUAL, ROW - PARK / NEUTRAL SIGNAL: B+ WHEN IGNITION CRANK (III) MANUAL, NAS - CLUTCH PEDAL SAFETY SWITCH (PARK / NEUTRAL SIGNAL): B+ WHEN ACTIVATED
O P11-41	STARTER RELAY DRIVE: TO ACTIVATE, ECM SWITCHES CIRCUIT TO GROUND
O P11-53	FUEL PUMP 2 DRIVE (TO FUEL PUMP 2 MODULE): PWM, 150 Hz, NORMAL POSITIVE DUTY CYCLE RANGE = 4% - 51%
I P11-65	GENERATOR FIELD RETURN SIGNAL: VARIABLE VOLTAGE BY GENERATOR OPERATING CONDITION
I P11-79	GENERATOR FAULT: CHARGE WARNING
C P11-123	CAN -
C P11-124	CAN +

Instrument Cluster

Pin	Description and Characteristic
I FC14-2	KEY-IN AUDIBLE WARNING: B+ WHEN KEY IN
B+ FC14-3	IGNITION SWITCHED POWER SUPPLY (I): B+
SG FC14-14	SIGNAL GROUND: GROUND
PG FC15-2	POWER GROUND: GROUND
B+ FC15-3	BATTERY POWER SUPPLY (LOGIC): B+
I FC15-4	PATS GROUND: GROUND
D FC15-5	PATS TRANSCIEVER: ENCODED COMMUNICATION
D FC15-6	PATS TRANSCIEVER: ENCODED COMMUNICATION
C FC15-18	CAN +
C FC15-19	CAN -

Transmission Control Module

Pin	Description and Characteristic
B+ GB2-9	IGNITION SWITCHED POWER SUPPLY: B+
O GB2-10	PARK / NEUTRAL SIGNAL: GROUND WHEN ACTIVATED
PG GB2-13	POWER GROUND: GROUND
PG GB2-16	POWER GROUND: GROUND

NOTE: Refer to the Appendix at the rear of this book for Network Messages.

The following abbreviations are used to represent values for Control Module Pin-Out data

I	Input	PG	Power Ground	C	CAN Network	D	Serial and Encoded Data
O	Output	SS	Sensor / Signal Supply V	S	SCP Network	V	Voltage (DC)
B+	Battery Voltage	SG	Sensor / Signal Ground	D2	D2B Network	PWM	Pulse Width Modulated

CAUTION: The information on this data page is furnished to aid the user in understanding circuit operation. THIS INFORMATION SHOULD BE USED FOR REFERENCE ONLY.

NOTE: The values listed are approximately those that can be expected at the control module connector pins with all circuit connections made and all components connected and fitted.

Fig. 02.1

COMPONENTS

Component	Connector(s)	Connector Description	Location
BATTERY	—	—	LUGGAGE COMPARTMENT
CLUTCH PEDAL SAFETY SWITCH	CA286	2-WAY / BLACK	TOP OF CLUTCH PEDAL (BOTTOM SWITCH)
ENGINE CONTROL MODULE	PI1	134-WAY / BLACK	FRONT BULKHEAD, PASSENGER SIDE
FRONT POWER DISTRIBUTION FUSE BOX	—	—	ENGINE COMPARTMENT, RH SIDE
GENERATOR (V6)	PI47 ST7	4-WAY / BLACK EYELET	ENGINE, RH SIDE, FRONT
IGNITION SWITCH	FC18	7-WAY / BLACK	STEERING COLUMN COWLING
INSTRUMENT CLUSTER	FC14 FC15 FC63	22-WAY / GREY 20-WAY / BLACK 22-WAY / BLACK	INSTRUMENT PANEL
PASSIVE ANTI-THEFT SYSTEM TRANSCIEVER	FC52	4-WAY / GREEN	STEERING COLUMN, IGNITION SWITCH
PRIMARY JUNCTION FUSE BOX	CA2 CA56 FC37 FH7 FH53	26-WAY / BLACK 8-WAY / BLACK 26-WAY / BLACK 6-WAY / BLACK 10-WAY / BLACK	RH 'A' POST
STARTER MEGAFUSE	—	—	LUGGAGE COMPARTMENT
STARTER MOTOR	—	—	ENGINE BLOCK, RH SIDE
STARTER RELAY	—	—	FRONT POWER DISTRIBUTION FUSE BOX - R20
TRANSMISSION CONTROL MODULE	GB2	16-WAY / BLACK	TRANSMISSION CONTROL VALVE ASSEMBLY

HARNES IN-LINE CONNECTORS

Connector	Connector Description / Location	Location
FH3	16-WAY / BLUE / CABIN HARNESS TO FRONT HARNESS	LH 'A' POST
GB1	16-WAY / GREY / ENGINE HARNESS TO TRANSMISSION HARNESS	ADJACENT TO TRANSMISSION BELL HOUSING
PI41	42-WAY / BLACK / ENGINE HARNESS TO VEHICLE HARNESSES	ENGINE COMPARTMENT, BULKHEAD, PASSENGER SIDE
PI42	8-WAY / BLACK / ENGINE HARNESS TO FRONT HARNESS	ENGINE COMPARTMENT, BULKHEAD, PASSENGER SIDE
ST4	2-WAY / GREY / FRONT HARNESS TO STARTER LINK	ENGINE COMPARTMENT, REARWARD OF RH WHEEL ARCH

GROUND

Ground	Location
FC38	UNDER CENTER OF INSTRUMENT PANEL, ON TRANSMISSION TUNNEL
JB1	LUGGAGE COMPARTMENT, BATTERY GROUND
PI40 (LHD)	ENGINE COMPARTMENT, BEHIND RH WHEEL ARCH LINER
PI40 (RHD)	ENGINE COMPARTMENT, BEHIND LH WHEEL ARCH LINER
ST2	ENGINE COMPARTMENT, BEHIND LH WHEEL ARCH LINER

FOR CONTROL MODULE PIN-OUT INFORMATION, UNFOLD PAGE TO LEFT.

Refer to the front of this book for detailed information and illustrations regarding the location and identification of harnesses, relays, fuses, grounds, control modules and control module pins.

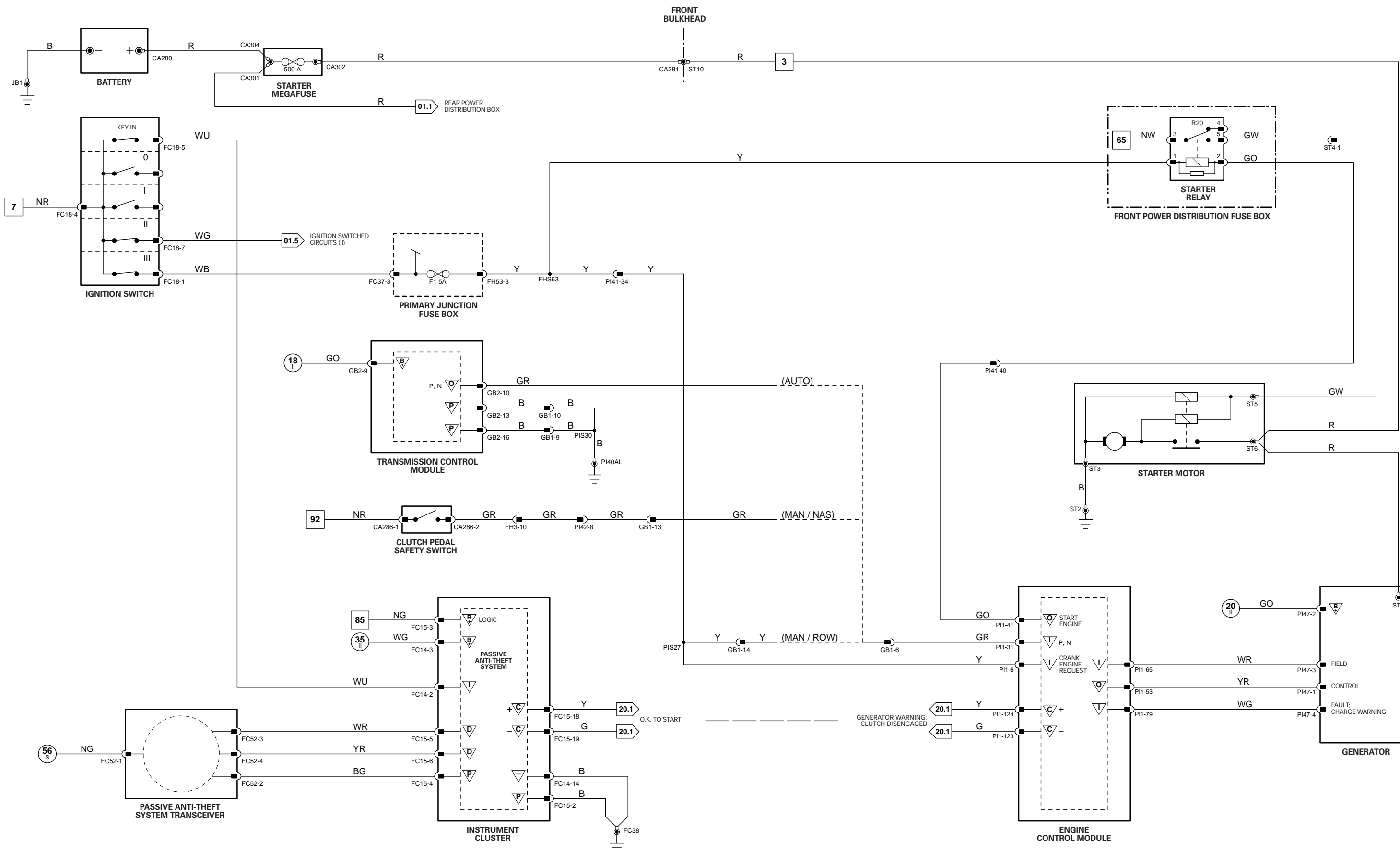

CONTROL MODULE PIN-OUT INFORMATION

Engine Control Module

Pin	Description and Characteristic
I P11-6	ENGINE CRANK: B+
I P11-31	AUTOMATIC - PARK / NEUTRAL SIGNAL: B+ WHEN ACTIVATED MANUAL, ROW - PARK / NEUTRAL SIGNAL: B+ WHEN IGNITION CRANK (III) MANUAL, NAS - CLUTCH PEDAL SAFETY SWITCH (PARK / NEUTRAL SIGNAL): B+ WHEN ACTIVATED
O P11-41	STARTER RELAY DRIVE: TO ACTIVATE, ECM SWITCHES CIRCUIT TO GROUND
I P11-79	GENERATOR FAULT; CHARGE WARNING
C P11-123	CAN -
C P11-124	CAN +

Instrument Cluster

Pin	Description and Characteristic
I FC14-2	KEY-IN AUDIBLE WARNING: B+ WHEN KEY IN
B+ FC14-3	IGNITION SWITCHED POWER SUPPLY (I): B+
SG FC14-14	SIGNAL GROUND: GROUND
PG FC15-2	POWER GROUND: GROUND
B+ FC15-3	BATTERY POWER SUPPLY (LOGIC): B+
I FC15-4	PATS GROUND: GROUND
D FC15-5	PATS TRANSCIVER: ENCODED COMMUNICATION
D FC15-6	PATS TRANSCIVER: ENCODED COMMUNICATION
C FC15-18	CAN +
C FC15-19	CAN -

Transmission Control Module

Pin	Description and Characteristic
B+ GB2-9	IGNITION SWITCHED POWER SUPPLY: B+
O GB2-10	PARK / NEUTRAL SIGNAL: GROUND WHEN ACTIVATED
PG GB2-13	POWER GROUND: GROUND
PG GB2-16	POWER GROUND: GROUND

NOTE: Refer to the Appendix at the rear of this book for Network Messages.

The following abbreviations are used to represent values for Control Module Pin-Out data

I	Input	PG	Power Ground	C	CAN Network	D	Serial and Encoded Data
O	Output	SS	Sensor / Signal Supply V	S	SCP Network	V	Voltage (DC)
B+	Battery Voltage	SG	Sensor / Signal Ground	D2	D2B Network	PWM	Pulse Width Modulated

CAUTION: The information on this data page is furnished to aid the user in understanding circuit operation. THIS INFORMATION SHOULD BE USED FOR REFERENCE ONLY.

NOTE: The values listed are approximately those that can be expected at the control module connector pins with all circuit connections made and all components connected and fitted.

Fig. 02.2

COMPONENTS

Component	Connector(s)	Connector Description	Location
BATTERY	—	—	LUGGAGE COMPARTMENT
ENGINE CONTROL MODULE	PI1	134-WAY / BLACK	FRONT BULKHEAD, PASSENGER SIDE
FRONT POWER DISTRIBUTION FUSE BOX	—	—	ENGINE COMPARTMENT, RH SIDE
GENERATOR (V8)	PI48 ST7	4-WAY / BLACK EYELET	ENGINE, RH SIDE, FRONT
IGNITION SWITCH	FC18	7-WAY / BLACK	STEERING COLUMN COWLING
INSTRUMENT CLUSTER	FC14 FC15 FC63	22-WAY / GREY 20-WAY / BLACK 22-WAY / BLACK	INSTRUMENT PANEL
PASSIVE ANTI-THEFT SYSTEM TRANSCIVER	FC52	4-WAY / GREEN	STEERING COLUMN, IGNITION SWITCH
PRIMARY JUNCTION FUSE BOX	CA2 CA56 FC37 FH7 FH53	26-WAY / BLACK 8-WAY / BLACK 26-WAY / BLACK 6-WAY / BLACK 10-WAY / BLACK	RH 'A' POST
STARTER MEGAFUSE	—	—	LUGGAGE COMPARTMENT
STARTER MOTOR	—	—	ENGINE BLOCK, RH SIDE
STARTER RELAY	—	—	FRONT POWER DISTRIBUTION FUSE BOX - R20
TRANSMISSION CONTROL MODULE	GB2	16-WAY / BLACK	TRANSMISSION CONTROL VALVE ASSEMBLY

HARNESS IN-LINE CONNECTORS

Connector	Connector Description / Location	Location
GB1	16-WAY / GREY / ENGINE HARNESS TO TRANSMISSION HARNESS	ADJACENT TO TRANSMISSION BELL HOUSING
PI41	42-WAY / BLACK / ENGINE HARNESS TO VEHICLE HARNESSES	ENGINE COMPARTMENT, BULKHEAD, PASSENGER SIDE
ST4	2-WAY / GREY / FRONT HARNESS TO STARTER LINK	ENGINE COMPARTMENT, REARWARD OF RH WHEEL ARCH

GROUNDINGS

Ground	Location
FC38	UNDER CENTER OF INSTRUMENT PANEL, ON TRANSMISSION TUNNEL
JB1	LUGGAGE COMPARTMENT, BATTERY GROUND
PI40 (LHD)	ENGINE COMPARTMENT, BEHIND RH WHEEL ARCH LINER
PI40 (RHD)	ENGINE COMPARTMENT, BEHIND LH WHEEL ARCH LINER
ST2	ENGINE COMPARTMENT, BEHIND LH WHEEL ARCH LINER

FOR CONTROL MODULE PIN-OUT INFORMATION, UNFOLD PAGE TO LEFT.

Refer to the front of this book for detailed information and illustrations regarding the location and identification of harnesses, relays, fuses, grounds, control modules and control module pins.

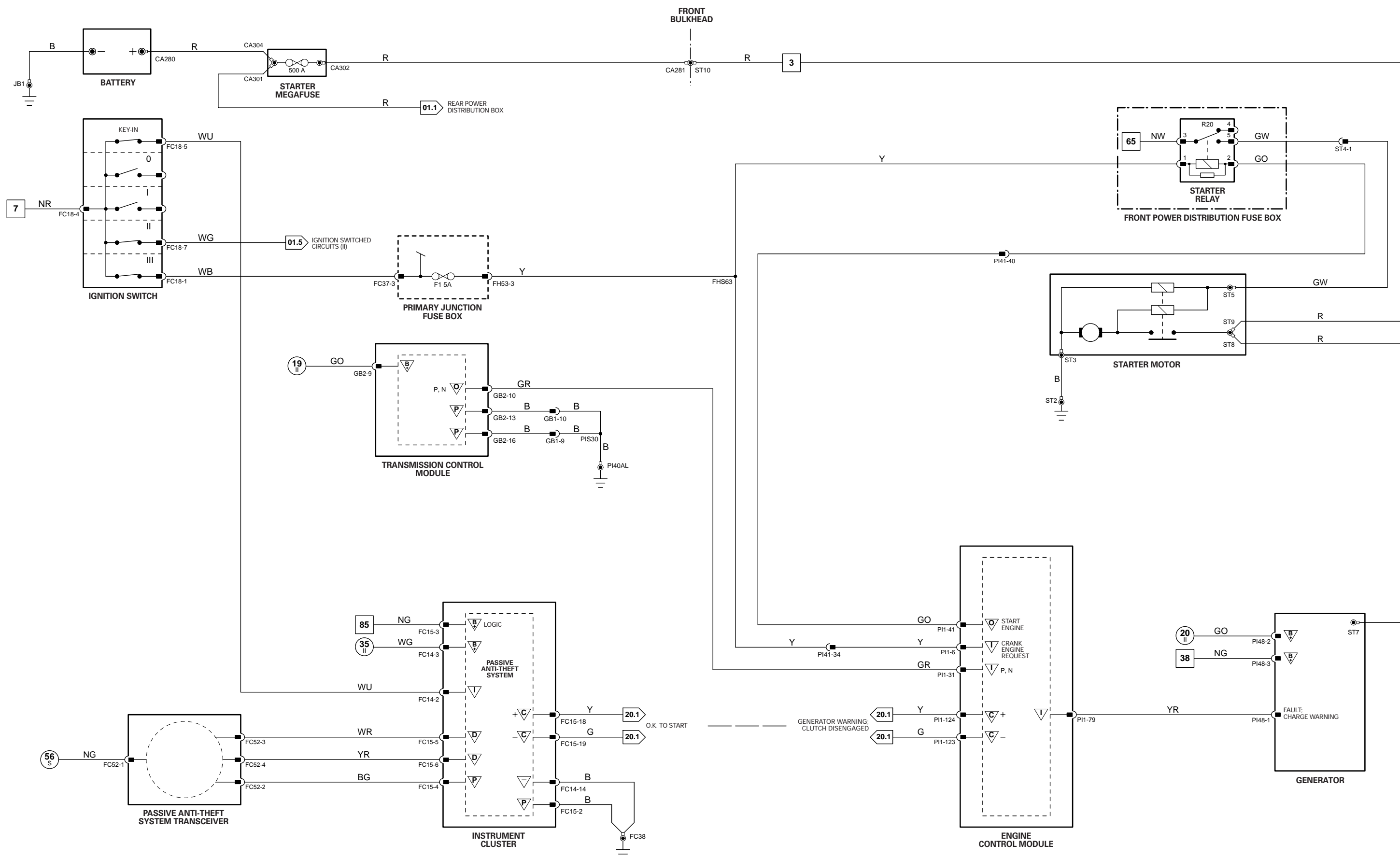

CONTROL MODULE PIN-OUT INFORMATION

Engine Control Module

Pin	Description and Characteristic
O	PI1-1 HO2 SENSOR HEATER CONTROL – 1/1: PWM, 1 CYCLE PER 128 mS, VARIABLE DUTY CYCLE
O	PI1-2 HO2 SENSOR HEATER CONTROL – 1/1: PWM, 1 CYCLE PER 128 mS, VARIABLE DUTY CYCLE
PG	PI1-4 POWER GROUND 1: GROUND
PG	PI1-5 POWER GROUND 2: GROUND
I	PI1-6 ENGINE CRANK: B+
I	PI1-7 IGNITION ON: B+
I	PI1-8 BRAKE ON / OFF SWITCH: NORMALLY OPEN / B+ WHEN ACTIVATED
I	PI1-10 INERTIA SWITCH: NORMALLY CLOSED / OPEN CIRCUIT WHEN ACTIVATED
SS	PI1-12 SENSOR POWER SUPPLY 1: NOMINAL 5 V
SS	PI1-13 SENSOR POWER SUPPLY 2: NOMINAL 5 V
SG	PI1-17 SMALL SIGNAL GROUND 1: GROUND
SG	PI1-18 SMALL SIGNAL GROUND 2: GROUND
SG	PI1-19 SENSOR GROUND 1: GROUND
SG	PI1-20 SENSOR GROUND 2: GROUND
B+	PI1-22 BATTERY POWER SUPPLY: B+
B+	PI1-23 EMS SWITCHED POWER SUPPLY 1: B+
B+	PI1-24 EMS SWITCHED POWER SUPPLY 2: B+
SG	PI1-29 HO2 SENSOR HEATER GROUND – 1/1: GROUND
SG	PI1-30 HO2 SENSOR HEATER GROUND – 1/1: GROUND
I	PI1-31 AUTOMATIC – PARK / NEUTRAL SIGNAL: B+ WHEN ACTIVATED MANUAL, ROW – PARK / NEUTRAL SIGNAL: B+ WHEN IGNITION CRANK (III) MANUAL, NAS – CLUTCH PEDAL SAFETY SWITCH (PARK / NEUTRAL SIGNAL): B+ WHEN ACTIVATED
I	PI1-36 CRANKSHAFT SENSOR SIGNAL: PULSED SIGNAL, 70 PULSES PER ENGINE CYCLE
SG	PI1-37 CRANKSHAFT SENSOR SIGNAL GROUND: GROUND
O	PI1-38 INTAKE MANIFOLD TUNING VALVE SOLENOID DRIVE – 1 / TOP: GROUND WHEN ACTIVATED
O	PI1-39 INTAKE MANIFOLD TUNING VALVE SOLENOID DRIVE – 2 / BOTTOM: GROUND WHEN ACTIVATED
O	PI1-40 EMS CONTROL RELAY DRIVE: TO ACTIVATE, ECM SWITCHES CIRCUIT TO GROUND
O	PI1-41 STARTER RELAY DRIVE: TO ACTIVATE, ECM SWITCHES CIRCUIT TO GROUND
SG	PI1-43 TP AND APP SIGNALS SHIELD: GROUND
I	PI1-44 MASS AIR FLOW SENSOR SIGNAL: NOMINAL 0 – 5 V BY ENGINE OPERATING CONDITION
SG	PI1-45 MASS AIR FLOW SENSOR GROUND: GROUND
SG	PI1-46 MASS AIR FLOW SENSOR GROUND: GROUND
I	PI1-50 ENGINE FUEL TEMPERATURE SENSOR SIGNAL, NOMINAL 0 – 5 V: NTC SENSOR – VOLTAGE DECREASES AS TEMPERATURE INCREASES
O	PI1-52 THROTTLE MOTOR RELAY DRIVE: TO ACTIVATE, ECM SWITCHES CIRCUIT TO GROUND
O	PI1-53 GENERATOR CONTROL: VARIABLE VOLTAGE
SG	PI1-54 THROTTLE MOTOR GROUND: GROUND
O	PI1-55 HO2 SENSOR HEATER CONTROL – 2/1: PWM, 1 CYCLE PER 128 mS, VARIABLE DUTY CYCLE
O	PI1-56 HO2 SENSOR HEATER CONTROL – 2/1: PWM, 1 CYCLE PER 128 mS, VARIABLE DUTY CYCLE
I	PI1-65 GENERATOR FIELD RETURN SIGNAL: VARIABLE VOLTAGE BY GENERATOR OPERATING CONDITION
O	PI1-66 EVAP CANISTER PURGE VALVE DRIVE: PWM, 10 Hz, POSITIVE DUTY CYCLE RANGE 7% – 100%
O	PI1-67 EVAP CANISTER CLOSE VALVE DRIVE: TO CLOSE, ECM SWITCHES CIRCUIT TO GROUND
I	PI1-68 BANK 2 CAMSHAFT SENSOR SIGNAL: PULSED SIGNAL, 4 PULSES PER ENGINE CYCLE
SG	PI1-69 BANK 2 CAMSHAFT SENSOR GROUND: GROUND
I	PI1-70 ENGINE COOLANT TEMPERATURE SENSOR SIGNAL, NOMINAL 0 – 5 V: NTC SENSOR – VOLTAGE DECREASES AS TEMPERATURE INCREASES
I	PI1-71 INTAKE AIR TEMPERATURE SENSOR SIGNAL, NOMINAL 0 – 5 V: NTC SENSOR – VOLTAGE DECREASES AS TEMPERATURE INCREASES
I	PI1-73 INJECTION PRESSURE SENSOR SIGNAL, NOMINAL 0 – 5 V: POTENTIOMETER – VOLTAGE INCREASES AS PRESSURE INCREASES
I	PI1-75 THROTTLE POSITION SENSOR 1 SIGNAL: IDLE = 0.60 V; FULL THROTTLE = 4.30 V
I	PI1-76 THROTTLE POSITION SENSOR 2 SIGNAL: IDLE = 1.48 V; FULL THROTTLE = 4.40 V
I	PI1-78 ENGINE OIL TEMPERATURE SENSOR SIGNAL, NOMINAL 0 – 5 V: NTC SENSOR – VOLTAGE DECREASES AS TEMPERATURE INCREASES
I	PI1-79 GENERATOR FAULT: CHARGE WARNING
O	PI1-80 THROTTLE MOTOR DRIVE: B+ TO ACTIVATE MOTOR
SG	PI1-81 HO2 SENSOR HEATER GROUND – 2/1: GROUND
SG	PI1-82 HO2 SENSOR HEATER GROUND – 2/1: GROUND
I	PI1-83 HO2 SENSOR 1/1 SIGNAL: VARIABLE CURRENT
I	PI1-84 HO2 SENSOR 1/1 SIGNAL: CONSTANT CURRENT
SG	PI1-91 HO2 SENSOR HEATERS 1/2, 2/2 GROUND: GROUND
O	PI1-92 HO2 SENSOR HEATER CONTROL – 1/2: PWM, 1 CYCLE PER 256 mS, POSITIVE DUTY CYCLE RANGE 0 mS = 0%, 77 mS = 30%, 256 mS = 100%
O	PI1-93 HO2 SENSOR HEATER CONTROL – 2/2: PWM, 1 CYCLE PER 256 mS, POSITIVE DUTY CYCLE RANGE 0 mS = 0%, 77 mS = 30%, 256 mS = 100%
I	PI1-94 BANK 1 CAMSHAFT SENSOR SIGNAL: PULSED SIGNAL, 4 PULSES PER ENGINE CYCLE
SG	PI1-95 BANK 1 CAMSHAFT SENSOR GROUND: GROUND
I	PI1-98 BANK 1 KNOCK SENSOR SIGNAL: VARIABLE VOLTAGE DEPENDENT ON ENGINE VIBRATION
I	PI1-99 BANK 2 KNOCK SENSOR SIGNAL: VARIABLE VOLTAGE DEPENDENT ON ENGINE VIBRATION
SG	PI1-100 SENSOR SHIELD: GROUND
I	PI1-102 ACCELERATOR PEDAL POSITION SENSOR 1 SIGNAL: FOOT OFF = 0.75 V; FULLY DEPRESSED = 3.40 V (AUTO) 3.20 (MAN)
I	PI1-103 ACCELERATOR PEDAL POSITION SENSOR 2 SIGNAL: FOOT OFF = 3.38 V; FULLY DEPRESSED = 2.05 V (AUTO) 2.14 V (MAN)
I	PI1-104 FUEL TANK PRESSURE SENSOR SIGNAL, NOMINAL 0 – 5 V: VOLTAGE INCREASES AS PRESSURE INCREASES
D	PI1-105 SERIAL DATA LINK: SERIAL COMMUNICATION
O	PI1-106 THROTTLE MOTOR DRIVE: B+ TO ACTIVATE MOTOR
I	PI1-107 HO2 SENSOR 2/1 SIGNAL: VARIABLE CURRENT
I	PI1-108 HO2 SENSOR 2/1 SIGNAL: CONSTANT CURRENT
O	PI1-109 BANK 1 VVT SOLENOID VALVE: PWM, 300Hz, POSITIVE DUTY CYCLE RANGE 0% – 100%
O	PI1-110 BANK 2 VVT SOLENOID VALVE: PWM, 300Hz, POSITIVE DUTY CYCLE RANGE 0% – 100%
SG	PI1-111 FUEL INJECTORS 2, 3, 5, 8 GROUND: GROUND
SG	PI1-116 FUEL INJECTORS 1, 4, 6, 7 GROUND: GROUND
C	PI1-123 CAN -
C	PI1-124 CAN +
I	PI1-127 MAP SENSOR SIGNAL, NOMINAL 0 – 5 V: VOLTAGE INCREASES AS MANIFOLD ABSOLUTE PRESSURE INCREASES
I	PI1-128 HO2 SENSOR 1/2 SIGNAL, NOMINAL 1 V SWING: 0.1 – 0.9 V SWING
I	PI1-129 HO2 SENSOR 2/2 SIGNAL, NOMINAL 1 V SWING: 0.1 – 0.9 V SWING
SG	PI1-130 HO2 SENSORS SHIELD: GROUND
B+	PI1-134 THROTTLE MOTOR POWER SUPPLY: B+ WHEN RELAY ACTIVATED

NOTE: Refer to the Appendix at the rear of this book for Network Messages.

The following abbreviations are used to represent values for Control Module Pin-Out data

I	Input	PG	Power Ground	C	CAN Network	D	Serial and Encoded Data
O	Output	SS	Sensor / Signal Supply V	S	SCP Network	V	Voltage (DC)
B+	Battery Voltage	SG	Sensor / Signal Ground	D2	D2B Network	PWM	Pulse Width Modulated

CAUTION: The information on this data page is furnished to aid the user in understanding circuit operation. THIS INFORMATION SHOULD BE USED FOR REFERENCE ONLY.

NOTE: The values listed are approximately those that can be expected at the control module connector pins with all circuit connections made and all components connected and fitted.

Fig. 03.1

COMPONENTS

Component	Connector(s)	Connector Description	Location
APP SENSOR	CA88	6-WAY / BLACK	TOP OF ACCELERATOR PEDAL
BRAKE ON / OFF SWITCH	CA37	2-WAY / GREEN	TOP OF BRAKE PEDAL
CKP SENSOR (V6)	PI55	2-WAY / BLACK	ENGINE TIMING COVER, CRANKSHAFT PULLEY
CMP SENSOR 1 (V6)	PI57	2-WAY / BLACK	BANK 1 (RH) CAMSHAFT COVER, FRONT
CMP SENSOR 2 (V6)	PI56	2-WAY / BLACK	BANK 2 (LH) CAMSHAFT COVER, FRONT
ECT SENSOR	PI25	2-WAY / BLACK	ENGINE VEE, COOLANT OUTLET CASTING
EFT SENSOR (V6)	IL9	2-WAY / BLACK	FUEL RAIL, FRONT
ENGINE CONTROL MODULE	PI1	134-WAY / BLACK	FRONT BULKHEAD, PASSENGER SIDE
EOT SENSOR	PI24	2-WAY / BLACK	ADJACENT TO OIL FILTER
EVAP CANISTER CLOSE VALVE	CA270	2-WAY / BLACK	ABOVE REAR AXLE (FUEL TANK COMPONENTS)
EVAP CANISTER PURGE VALVE	FH111	2-WAY / BLACK	ENGINE COMPARTMENT, LH SIDE, ADJACENT TO SUSPENSION TURRET
FRONT POWER DISTRIBUTION FUSE BOX	—	—	ENGINE COMPARTMENT, RH SIDE
FTP SENSOR	FP1	3-WAY / BLACK	FUEL TANK PIPING, LH SIDE (UNDER ACCESS PLATE)
HO2 SENSOR DOWNSTREAM 1/2	PI11	4-WAY / BLACK	RH EXHAUST, CATALYST CENTER
HO2 SENSOR DOWNSTREAM 2/2	PI13	4-WAY / BLACK	LH EXHAUST, CATALYST CENTER
HO2 SENSOR UPSTREAM 1/1	PI10	4-WAY / BLACK	RH EXHAUST, TOP OF CATALYST
HO2 SENSOR UPSTREAM 2/1	PI12	4-WAY / BLACK	LH EXHAUST, TOP OF CATALYST
IMT SOLENOID VALVE 1	PI30	2-WAY / BLACK	INTAKE MANIFOLD, REAR
IMT SOLENOID VALVE 2	PI31	2-WAY / BLACK	INTAKE MANIFOLD, REAR
IP SENSOR (V6)	IL12	3-WAY / BLACK	FUEL RAIL, REAR
KNOCK SENSOR 1 (V6)	PI20	2-WAY / BLACK	ENGINE VEE, TOWARD FRONT, BANK 2 (FRONT SENSOR)
KNOCK SENSOR 2 (V6)	PI19	2-WAY / BLACK	ENGINE BLOCK, REAR, BANK 1 (REAR SENSOR)
MAF SENSOR	PI14	5-WAY / BLACK	ENGINE AIR INTAKE, ADJACENT TO AIR CLEANER
MAP SENSOR (V6)	PI29	4-WAY / BLACK	INTAKE MANIFOLD, UPPER REAR
THROTTLE MOTOR (V6)	PI18	2-WAY / BLACK	ENGINE AIR INTAKE, FRONT
THROTTLE MOTOR RELAY	—	—	FRONT POWER DISTRIBUTION FUSE BOX – R4
TP SENSOR	PI26	4-WAY / BLACK	THROTTLE BODY, THROTTLE SHAFT
VVT SOLENOID VALVE 1	PI16	2-WAY / BLACK	RH CYLINDER HEAD, FRONT
VVT SOLENOID VALVE 2	PI17	2-WAY / BLACK	LH CYLINDER HEAD, FRONT

HARNESS IN-LINE CONNECTORS

Connector	Connector Description / Location	Location
FC12	14-WAY / GREY / FASCIA HARNESS TO FRONT HARNESS	BEHIND INSTRUMENT PANEL, PASSENGER SIDE
FC26	16-WAY / BLUE / CABIN HARNESS TO FASCIA HARNESS	BEHIND INSTRUMENT PANEL, DRIVER SIDE
FH1	20-WAY / BLACK / CABIN HARNESS TO FRONT HARNESS	RH 'A' POST, LOWER
FH3	16-WAY / BLUE / CABIN HARNESS TO FRONT HARNESS	LH 'A' POST
FP2	8-WAY / BLACK / CABIN HARNESS TO FUEL PUMP HARNESS	TOP OF FUEL TANK, RH SIDE
IL10	12-WAY / BLACK / ENGINE HARNESS TO FUEL INJECTOR LINK	REAR OF ENGINE
PI41	42-WAY / BLACK / ENGINE HARNESS TO VEHICLE HARNESSES	ENGINE COMPARTMENT, BULKHEAD, PASSENGER SIDE

GROUND S

Ground	Location
PI40 (LHD)	ENGINE COMPARTMENT, BEHIND RH WHEEL ARCH LINER
PI40 (RHD)	ENGINE COMPARTMENT, BEHIND LH WHEEL ARCH LINER

FOR CONTROL MODULE PIN-OUT INFORMATION, UNFOLD PAGE TO LEFT.

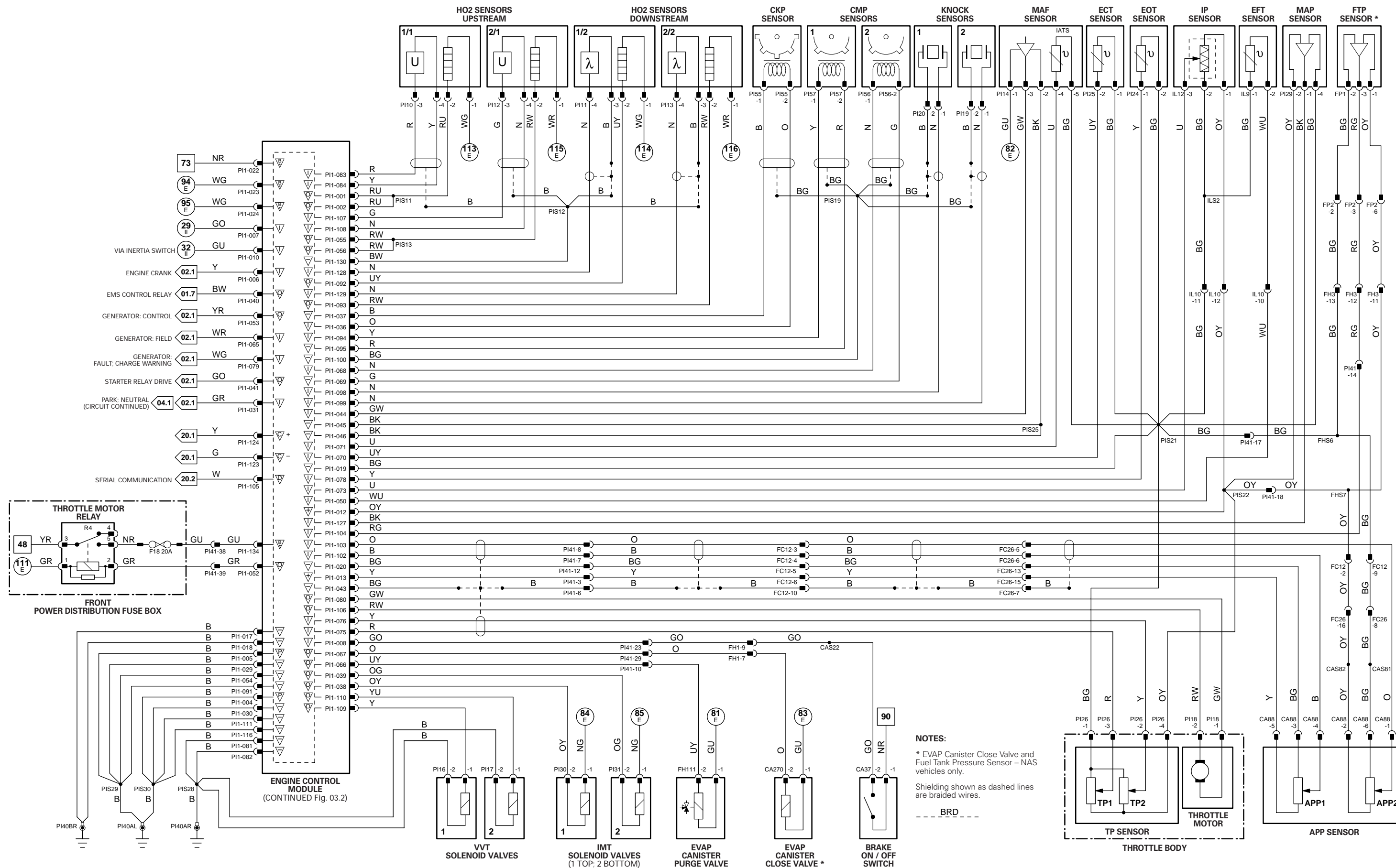

NOTES:

- * EVAP Canister Close Valve and Fuel Tank Pressure Sensor – NAS vehicles only.
- Shielding shown as dashed lines are braided wires.
- BRD

CONTROL MODULE PIN-OUT INFORMATION

Engine Control Module

Pin	Description and Characteristic
I P11-9	BRAKE CANCEL SWITCH: NORMALLY CLOSED / GROUND WHEN ACTIVATED
SS P11-12	SENSOR POWER SUPPLY 1: NOMINAL 5 V
SG P11-19	SENSOR GROUND 1: GROUND
O P11-27	FUEL PUMP DRIVE SIGNAL (TO REGM): PWM, 150 Hz, NORMAL POSITIVE DUTY CYCLE RANGE = 4% - 51%
I P11-33	CLUTCH CANCEL SWITCH: NORMALLY CLOSED / GROUND WHEN ACTIVATED
O P11-34	AIR CONDITIONING COMPRESSOR CLUTCH RELAY DRIVE: TO ACTIVATE, ECM SWITCHES CIRCUIT TO GROUND
SS P11-47	SPEED CONTROL SWITCH REQUEST: STEPPED RESISTANCE
I P11-48	SPEED CONTROL SWITCHES SIGNAL GROUND: GROUND
O P11-51	COOLING FAN MODULE CONTROL: PWM, 140Hz, POSITIVE DUTY CYCLE RANGE 7% - 95%
O P11-61	IGNITION COIL ACTIVATE - CYLINDER 2: TO ACTIVATE, ECM SWITCHES CIRCUIT TO GROUND
O P11-62	IGNITION COIL ACTIVATE - CYLINDER 4: TO ACTIVATE, ECM SWITCHES CIRCUIT TO GROUND
O P11-63	IGNITION COIL ACTIVATE - CYLINDER 6: TO ACTIVATE, ECM SWITCHES CIRCUIT TO GROUND
O P11-87	IGNITION COIL ACTIVATE - CYLINDER 1: TO ACTIVATE, ECM SWITCHES CIRCUIT TO GROUND
O P11-88	IGNITION COIL ACTIVATE - CYLINDER 3: TO ACTIVATE, ECM SWITCHES CIRCUIT TO GROUND
O P11-89	IGNITION COIL ACTIVATE - CYLINDER 5: TO ACTIVATE, ECM SWITCHES CIRCUIT TO GROUND
O P11-113	FUEL INJECTOR DRIVE - CYLINDER 5: TO ACTIVATE, ECM SWITCHES CIRCUIT TO GROUND
O P11-114	FUEL INJECTOR DRIVE - CYLINDER 3: TO ACTIVATE, ECM SWITCHES CIRCUIT TO GROUND
O P11-115	FUEL INJECTOR DRIVE - CYLINDER 1: TO ACTIVATE, ECM SWITCHES CIRCUIT TO GROUND
O P11-118	FUEL INJECTOR DRIVE - CYLINDER 6: TO ACTIVATE, ECM SWITCHES CIRCUIT TO GROUND
O P11-119	FUEL INJECTOR DRIVE - CYLINDER 4: TO ACTIVATE, ECM SWITCHES CIRCUIT TO GROUND
O P11-120	FUEL INJECTOR DRIVE - CYLINDER 2: TO ACTIVATE, ECM SWITCHES CIRCUIT TO GROUND
I P11-121	AIR CONDITIONING PRESSURE SENSOR SIGNAL, NOMINAL 0 - 5 V: TRANSDUCER - VOLTAGE INCREASES AS PRESSURE INCREASES
I P11-131	IGNITION MONITOR BANK 1: PULSED SIGNAL, 3 PULSES PER ENGINE CYCLE
I P11-132	IGNITION MONITOR BANK 2: PULSED SIGNAL, 3 PULSES PER ENGINE CYCLE

Rear Electronic Control Module

Pin	Description and Characteristic
B+ CA100-8	IGNITION SWITCHED POWER SUPPLY (I): B+
B+ CA101-1	FUEL PUMP POWER SUPPLY: B+ WHEN FUEL PUMP RELAY IS ACTIVATED
SG CA101-2	LOGIC GROUND / FUEL PUMP DRIVE SHIELD: GROUND
B+ CA101-3	BATTERY POWER SUPPLY: B+
O CA101-11	FUEL PUMP SUPPLY VOLTAGE: B+
O CA101-12	FUEL PUMP ACTIVATE: GROUND (PWM)
S CA102-1	SCP +
S CA102-2	SCP -
I CA103-19	FUEL PUMP DRIVE SIGNAL: PWM, 150 Hz, NORMAL POSITIVE DUTY CYCLE RANGE = 4% - 51%

NOTE: Refer to the Appendix at the rear of this book for Network Messages.

The following abbreviations are used to represent values for Control Module Pin-Out data

I	Input	PG	Power Ground	C	CAN Network	D	Serial and Encoded Data
O	Output	SS	Sensor / Signal Supply V	S	SCP Network	V	Voltage (DC)
B+	Battery Voltage	SG	Sensor / Signal Ground	D2	D2B Network	PWM	Pulse Width Modulated

CAUTION: The information on this data page is furnished to aid the user in understanding circuit operation. THIS INFORMATION SHOULD BE USED FOR REFERENCE ONLY.

NOTE: The values listed are approximately those that can be expected at the control module connector pins with all circuit connections made and all components connected and fitted.

Fig. 03.2

COMPONENTS

Component	Connector(s)	Connector Description	Location
AIR CONDITIONING COMPRESSOR CLUTCH	PI49	2-WAY / BLACK	LOWER LH SIDE OF ENGINE
AIR CONDITIONING COMPRESSOR CLUTCH RELAY	—	—	FRONT POWER DISTRIBUTION FUSE BOX - R8
AIR CONDITIONING PRESSURE SENSOR	FH110	4-WAY / BLACK	ENGINE COMPARTMENT, LH SIDE, HIGH PRESSURE REFRIGERANT LINE, BETWEEN COMPRESSOR AND CONDENSER
BRAKE CANCEL SWITCH	CA36	2-WAY / GREY	TOP OF BRAKE PEDAL
CLUTCH CANCEL SWITCH	CA285 (LHD) CA291 (RHD)	2-WAY / BLACK 5-WAY / BLACK	TOP OF CLUTCH PEDAL (TOP SWITCH)
COOLING FAN MODULE	FH108 FH109	2-WAY / BLACK 2-WAY / BLACK	ENGINE COMPARTMENT, RH FRONT, REARWARD OF RADIATOR
ENGINE CONTROL MODULE	PI1	134-WAY / BLACK	FRONT BULKHEAD, PASSENGER SIDE
FRONT POWER DISTRIBUTION FUSE BOX	—	—	ENGINE COMPARTMENT, RH SIDE
FUEL INJECTOR 1 (V6)	IL3	2-WAY / BLACK	FUEL RAIL / INTAKE MANIFOLD
FUEL INJECTOR 2 (V6)	IL6	2-WAY / BLACK	FUEL RAIL / INTAKE MANIFOLD
FUEL INJECTOR 3 (V6)	IL4	2-WAY / BLACK	FUEL RAIL / INTAKE MANIFOLD
FUEL INJECTOR 4 (V6)	IL7	2-WAY / BLACK	FUEL RAIL / INTAKE MANIFOLD
FUEL INJECTOR 5 (V6)	IL5	2-WAY / BLACK	FUEL RAIL / INTAKE MANIFOLD
FUEL INJECTOR 6 (V6)	IL8	2-WAY / BLACK	FUEL RAIL / INTAKE MANIFOLD
FUEL PUMP 1	FP2 FP4	8-WAY / BLACK 4-WAY / BLACK	FUEL TANK, RH SIDE
FUEL PUMP RELAY	—	—	REAR POWER DISTRIBUTION FUSE BOX - R15
IGNITION CAPACITOR	PI54	2-WAY / BLACK	LH CYLINDER HEAD, REAR
IGNITION MODULE AND COIL 1	PI2	4-WAY / BLACK	RH CYLINDER HEAD
IGNITION MODULE AND COIL 2	PI6	4-WAY / BLACK	LH CYLINDER HEAD
IGNITION MODULE AND COIL 3	PI3	4-WAY / BLACK	RH CYLINDER HEAD
IGNITION MODULE AND COIL 4	PI7	4-WAY / BLACK	LH CYLINDER HEAD
IGNITION MODULE AND COIL 5	PI4	4-WAY / BLACK	RH CYLINDER HEAD
IGNITION MODULE AND COIL 6	PI8	4-WAY / BLACK	LH CYLINDER HEAD
REAR ELECTRONIC CONTROL MODULE	CA63 CA100 CA101 CA102 CA103	17-WAY / BLACK 12-WAY / BLACK 20-WAY / BLACK 22-WAY / BLACK 26-WAY / NATURAL	LUGGAGE COMPARTMENT, RH REAR
REAR POWER DISTRIBUTION FUSE BOX	—	—	LUGGAGE COMPARTMENT
STEERING WHEEL SPEED CONTROL SWITCHES	SO2	6-WAY / BLACK	STEERING WHEEL

HARNESS IN-LINE CONNECTORS

Connector	Connector Description / Location	Location
FC10	14-WAY / GREEN / FASCIA HARNESS TO FRONT HARNESS	BEHIND INSTRUMENT PANEL, RH SIDE
FC117	10-WAY / BLACK / STEERING WHEEL CASSETTE	STEERING COLUMN
IL10	12-WAY / BLACK / ENGINE HARNESS TO FUEL INJECTOR LINK	REAR OF ENGINE
PI41	42-WAY / BLACK / ENGINE HARNESS TO VEHICLE HARNESSES	ENGINE COMPARTMENT, BULKHEAD, PASSENGER SIDE
PI42	8-WAY / BLACK / ENGINE HARNESS TO FRONT HARNESS	ENGINE COMPARTMENT, BULKHEAD, PASSENGER SIDE
FH1	20-WAY / BLACK / CABIN HARNESS TO FRONT HARNESS	RH 'A' POST, LOWER
FH3	16-WAY / BLUE / CABIN HARNESS TO FRONT HARNESS	LH 'A' POST

GROUNDINGS

Ground	Location
CA156	LUGGAGE COMPARTMENT, RH SIDE
FH22	ENGINE COMPARTMENT, BEHIND LH HEADLAMP
FH42	ENGINE COMPARTMENT, BEHIND RH HEADLAMP
FH95	ENGINE COMPARTMENT, BEHIND LH HEADLAMP (RADIATOR FAN GROUND)
PI51	ENGINE COMPARTMENT, ENGINE BLOCK

FOR CONTROL MODULE PIN-OUT INFORMATION, UNFOLD PAGE TO LEFT.

Refer to the front of this book for detailed information and illustrations regarding the location and identification of harnesses, relays, fuses, grounds, control modules and control module pins.

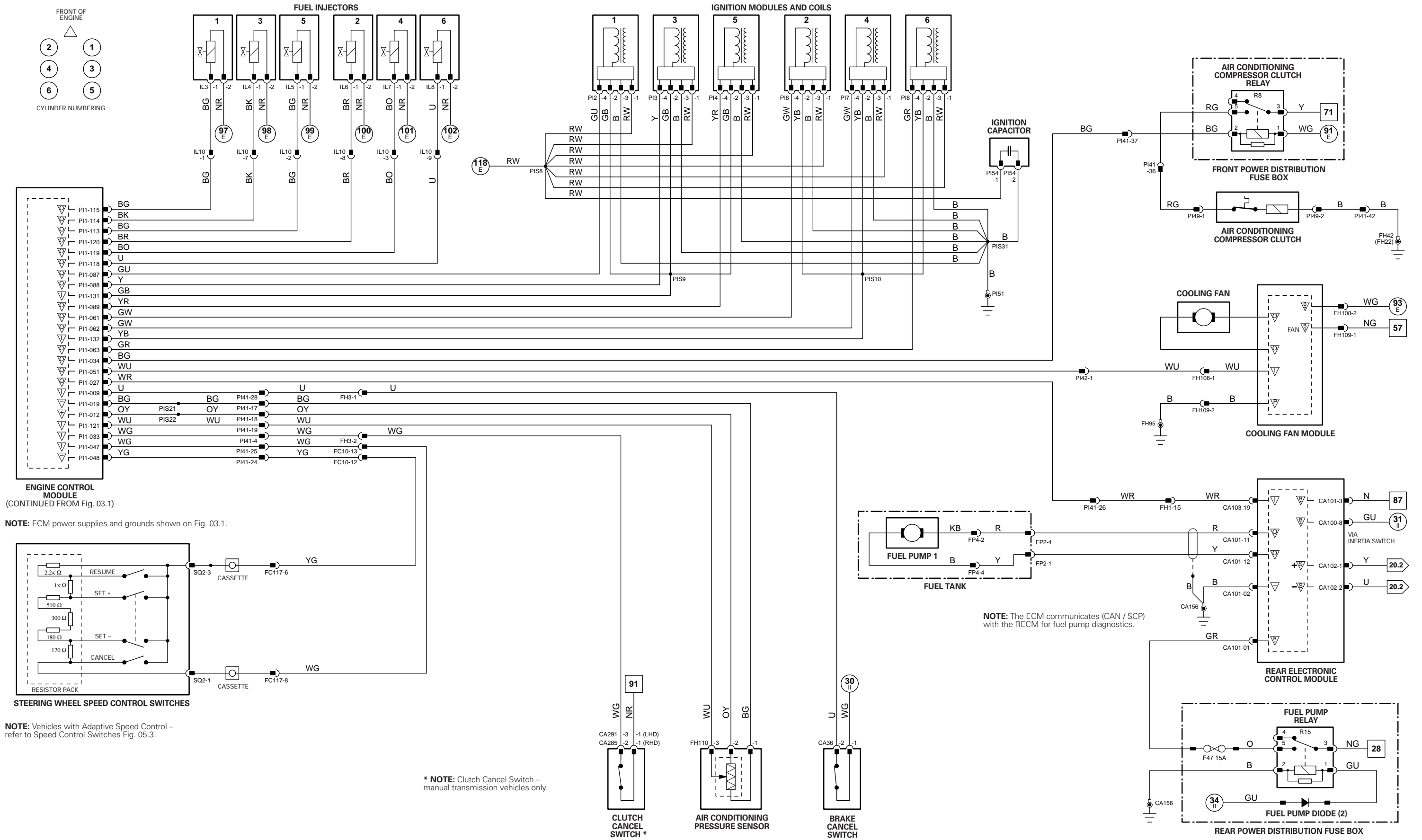

CONTROL MODULE PIN-OUT INFORMATION

Engine Control Module

Pin	Description and Characteristic
O	PI1-1 HO2 SENSOR HEATER CONTROL - 1/1: PWM, 1 CYCLE PER 128 mS, VARIABLE DUTY CYCLE
O	PI1-2 HO2 SENSOR HEATER CONTROL - 1/1: PWM, 1 CYCLE PER 128 mS, VARIABLE DUTY CYCLE
PG	PI1-4 POWER GROUND 1: GROUND
PG	PI1-5 POWER GROUND 2: GROUND
I	PI1-6 ENGINE CRANK: B+
I	PI1-7 IGNITION ON: B+
I	PI1-8 BRAKE ON / OFF SWITCH: NORMALLY OPEN / B+ WHEN ACTIVATED
I	PI1-10 INERTIA SWITCH: NORMALLY CLOSED / OPEN CIRCUIT WHEN ACTIVATED
SS	PI1-12 SENSOR POWER SUPPLY 1: NOMINAL 5 V
SS	PI1-13 SENSOR POWER SUPPLY 2: NOMINAL 5 V
SG	PI1-17 SMALL SIGNAL GROUND 1: GROUND
SG	PI1-18 SMALL SIGNAL GROUND 2: GROUND
SG	PI1-19 SENSOR GROUND 1: GROUND
SG	PI1-20 SENSOR GROUND 2: GROUND
B+	PI1-22 BATTERY POWER SUPPLY: B+
B+	PI1-23 EMS SWITCHED POWER SUPPLY 1: B+
B+	PI1-24 EMS SWITCHED POWER SUPPLY 2: B+
SG	PI1-29 HO2 SENSOR HEATER GROUND - 1/1: GROUND
SG	PI1-30 HO2 SENSOR HEATER GROUND - 1/1: GROUND
I	PI1-31 AUTOMATIC - PARK / NEUTRAL SIGNAL: B+ WHEN ACTIVATED MANUAL, ROW - PARK / NEUTRAL SIGNAL: B+ WHEN IGNITION CRANK (III) MANUAL, NAS - CLUTCH PEDAL SAFETY SWITCH (PARK / NEUTRAL SIGNAL): B+ WHEN ACTIVATED
I	PI1-36 CRANKSHAFT SENSOR SIGNAL: PULSED SIGNAL, 70 PULSES PER ENGINE CYCLE
SG	PI1-37 CRANKSHAFT SENSOR SIGNAL GROUND: GROUND
O	PI1-40 EMS CONTROL RELAY DRIVE: TO ACTIVATE, ECM SWITCHES CIRCUIT TO GROUND
O	PI1-41 STARTER RELAY DRIVE: TO ACTIVATE, ECM SWITCHES CIRCUIT TO GROUND
SG	PI1-43 TP AND APP SIGNALS SHIELD: GROUND
I	PI1-44 MASS AIR FLOW SENSOR SIGNAL: NOMINAL 0 - 5 V BY ENGINE OPERATING CONDITION
SG	PI1-45 MASS AIR FLOW SENSOR GROUND: GROUND
SG	PI1-46 MASS AIR FLOW SENSOR GROUND: GROUND
I	PI1-50 ENGINE FUEL TEMPERATURE SENSOR SIGNAL, NOMINAL 0 - 5 V: NTC SENSOR - VOLTAGE DECREASES AS TEMPERATURE INCREASES
O	PI1-52 THROTTLE MOTOR RELAY DRIVE: TO ACTIVATE, ECM SWITCHES CIRCUIT TO GROUND
SG	PI1-54 THROTTLE MOTOR GROUND: GROUND
O	PI1-55 HO2 SENSOR HEATER CONTROL - 2/1: PWM, 1 CYCLE PER 128 mS, VARIABLE DUTY CYCLE
O	PI1-56 HO2 SENSOR HEATER CONTROL - 2/1: PWM, 1 CYCLE PER 128 mS, VARIABLE DUTY CYCLE
O	PI1-57 EGR DRIVE 1: B+; EGR DRIVE 1, 2, 3 AND 4 ARE OPERATED IN TURN
O	PI1-58 EGR DRIVE 2: B+; EGR DRIVE 1, 2, 3 AND 4 ARE OPERATED IN TURN
O	PI1-59 EGR DRIVE 3: B+; EGR DRIVE 1, 2, 3 AND 4 ARE OPERATED IN TURN
O	PI1-60 EGR DRIVE 4: B+; EGR DRIVE 1, 2, 3 AND 4 ARE OPERATED IN TURN
O	PI1-66 EVAP CANISTER PURGE VALVE DRIVE: PWM, 10 Hz, POSITIVE DUTY CYCLE RANGE 7% - 100%
O	PI1-67 EVAP CANISTER CLOSE VALVE DRIVE: TO CLOSE, ECM SWITCHES CIRCUIT TO GROUND
I	PI1-68 BANK 2 CAMSHAFT SENSOR SIGNAL: PULSED SIGNAL, 4 PULSES PER ENGINE CYCLE
SG	PI1-69 BANK 2 CAMSHAFT SENSOR GROUND: GROUND
I	PI1-70 ENGINE COOLANT TEMPERATURE SENSOR SIGNAL, NOMINAL 0 - 5 V: NTC SENSOR - VOLTAGE DECREASES AS TEMPERATURE INCREASES
I	PI1-71 INTAKE AIR TEMPERATURE SENSOR SIGNAL, NOMINAL 0 - 5 V: NTC SENSOR - VOLTAGE DECREASES AS TEMPERATURE INCREASES
I	PI1-73 INJECTION PRESSURE SENSOR SIGNAL, NOMINAL 0 - 5 V: POTENTIOMETER - VOLTAGE INCREASES AS PRESSURE INCREASES
I	PI1-75 THROTTLE POSITION SENSOR 1 SIGNAL: IDLE = 0.60 V; FULL THROTTLE = 4.30 V
I	PI1-76 THROTTLE POSITION SENSOR 2 SIGNAL: IDLE = 1.48 V; FULL THROTTLE = 4.40 V
I	PI1-78 ENGINE OIL TEMPERATURE SENSOR SIGNAL, NOMINAL 0 - 5 V: NTC SENSOR - VOLTAGE DECREASES AS TEMPERATURE INCREASES
I	PI1-79 GENERATOR FAULT: CHARGE WARNING
O	PI1-80 THROTTLE MOTOR DRIVE: B+ TO ACTIVATE MOTOR
SG	PI1-81 HO2 SENSOR HEATER GROUND - 2/1: GROUND
SG	PI1-82 HO2 SENSOR HEATER GROUND - 2/1: GROUND
I	PI1-83 HO2 SENSOR 1/1 SIGNAL: VARIABLE CURRENT
I	PI1-84 HO2 SENSOR 1/1 SIGNAL: CONSTANT CURRENT
SG	PI1-91 HO2 SENSOR HEATERS 1/2, 2/2 GROUND: GROUND
O	PI1-92 HO2 SENSOR HEATER CONTROL - 1/2: PWM, 1 CYCLE PER 256 mS, POSITIVE DUTY CYCLE RANGE 0 mS = 0%, 77 mS = 30%, 256 mS = 100%
O	PI1-93 HO2 SENSOR HEATER CONTROL - 2/2: PWM, 1 CYCLE PER 256 mS, POSITIVE DUTY CYCLE RANGE 0 mS = 0%, 77 mS = 30%, 256 mS = 100%
I	PI1-94 BANK 1 CAMSHAFT SENSOR SIGNAL: PULSED SIGNAL, 4 PULSES PER ENGINE CYCLE
SG	PI1-95 BANK 1 CAMSHAFT SENSOR GROUND: GROUND
I	PI1-98 BANK 1 KNOCK SENSOR SIGNAL: VARIABLE VOLTAGE DEPENDENT ON ENGINE VIBRATION
I	PI1-99 BANK 2 KNOCK SENSOR SIGNAL: VARIABLE VOLTAGE DEPENDENT ON ENGINE VIBRATION
SG	PI1-100 SENSOR SHIELD: GROUND
I	PI1-102 ACCELERATOR PEDAL POSITION SENSOR 1 SIGNAL: FOOT OFF = 0.75 V; FULLY DEPRESSED = 3.40 V (AUTO) 3.20 (MAN)
I	PI1-103 ACCELERATOR PEDAL POSITION SENSOR 2 SIGNAL: FOOT OFF = 3.38 V; FULLY DEPRESSED = 2.05 V (AUTO) 2.14 V (MAN)
I	PI1-104 FUEL TANK PRESSURE SENSOR SIGNAL, NOMINAL 0 - 5 V: VOLTAGE INCREASES AS PRESSURE INCREASES
D	PI1-105 SERIAL DATA LINK: SERIAL COMMUNICATION
O	PI1-106 THROTTLE MOTOR DRIVE: B+ TO ACTIVATE MOTOR
I	PI1-107 HO2 SENSOR 2/1 SIGNAL: VARIABLE CURRENT
I	PI1-108 HO2 SENSOR 2/1 SIGNAL: CONSTANT CURRENT
O	PI1-109 BANK 1 VVT SOLENOID VALVE: PWM, 300Hz, POSITIVE DUTY CYCLE RANGE 0% - 100%
O	PI1-110 BANK 2 VVT SOLENOID VALVE: PWM, 300Hz, POSITIVE DUTY CYCLE RANGE 0% - 100%
SG	PI1-111 FUEL INJECTORS 2, 3, 5, 8 GROUND: GROUND
SG	PI1-116 FUEL INJECTORS 1, 4, 6, 7 GROUND: GROUND
C	PI1-123 CAN -
C	PI1-124 CAN +
I	PI1-127 MAP SENSOR SIGNAL, NOMINAL 0 - 5 V: VOLTAGE INCREASES AS MANIFOLD ABSOLUTE PRESSURE INCREASES
I	PI1-128 HO2 SENSOR 1/2 SIGNAL, NOMINAL 1 V SWING: 0.1 - 0.9 V SWING
I	PI1-129 HO2 SENSOR 2/2 SIGNAL, NOMINAL 1 V SWING: 0.1 - 0.9 V SWING
SG	PI1-130 HO2 SENSORS SHIELD: GROUND
B+	PI1-134 THROTTLE MOTOR POWER SUPPLY: B+ WHEN RELAY ACTIVATED

NOTE: Refer to the Appendix at the rear of this book for Network Messages.

The following abbreviations are used to represent values for Control Module Pin-Out data

I	Input	PG	Power Ground	C	CAN Network	D	Serial and Encoded Data
O	Output	SS	Sensor / Signal Supply V	S	SCP Network	V	Voltage (DC)
B+	Battery Voltage	SG	Sensor / Signal Ground	D2	D2B Network	PWM	Pulse Width Modulated

CAUTION: The information on this data page is furnished to aid the user in understanding circuit operation. THIS INFORMATION SHOULD BE USED FOR REFERENCE ONLY.

NOTE: The values listed are approximately those that can be expected at the control module connector pins with all circuit connections made and all components connected and fitted.

Fig. 03.3

COMPONENTS

Component	Connector(s)	Connector Description	Location
APP SENSOR	CA88	6-WAY / BLACK	TOP OF ACCELERATOR PEDAL
BRAKE ON / OFF SWITCH	CA37	2-WAY / GREEN	TOP OF BRAKE PEDAL
CKP SENSOR (V8)	PI21	2-WAY / BLACK	ENGINE UNDER SIDE, FORWARD OF BELL HOUSING
CMP SENSOR 1 (V8)	PI23	2-WAY / BLACK	BANK 1 (RH) CAMSHAFT COVER, FRONT
CMP SENSOR 2 (V8)	PI22	2-WAY / BLACK	BANK 2 (LH) CAMSHAFT COVER, FRONT
ECT SENSOR	PI25	2-WAY / BLACK	ENGINE VEE, COOLANT OUTLET CASTING
EFT SENSOR (V8)	PI27	2-WAY / BLACK	FUEL RAIL, RH REAR
EGR VALVE (V8 N/A)	PI15	6-WAY / BLACK	INTAKE MANIFOLD, RH FRONT
ENGINE CONTROL MODULE	PI1	134-WAY / BLACK	FRONT BULKHEAD, PASSENGER SIDE
EOT SENSOR	PI24	2-WAY / BLACK	ADJACENT TO OIL FILTER
EVAP CANISTER CLOSE VALVE	CA270	2-WAY / BLACK	ABOVE REAR AXLE (FUEL TANK COMPONENTS)
EVAP CANISTER PURGE VALVE	FH111	2-WAY / BLACK	ENGINE COMPARTMENT, LH SIDE, ADJACENT TO SUSPENSION TURRET
FRONT POWER DISTRIBUTION FUSE BOX	—	—	ENGINE COMPARTMENT, RH SIDE
FTP SENSOR	FP1	3-WAY / BLACK	FUEL TANK PIPING, LH SIDE (UNDER ACCESS PLATE)
HO2 SENSOR DOWNSTREAM 1/2	PI11	4-WAY / BLACK	RH EXHAUST, CATALYST CENTER
HO2 SENSOR DOWNSTREAM 2/2	PI13	4-WAY / BLACK	LH EXHAUST, CATALYST CENTER
HO2 SENSOR UPSTREAM 1/1	PI10	4-WAY / BLACK	RH EXHAUST, TOP OF CATALYST
HO2 SENSOR UPSTREAM 2/1	PI12	4-WAY / BLACK	LH EXHAUST, TOP OF CATALYST
IP SENSOR (V8 N/A)	PI28	3-WAY / BLACK	FUEL RAIL, RH FRONT
KNOCK SENSOR 1 (V8)	PI20	2-WAY / BLACK	ENGINE VEE, BANK 1
KNOCK SENSOR 2 (V8)	PI19	2-WAY / BLACK	ENGINE VEE, BANK 2
MAF SENSOR	PI14	5-WAY / BLACK	ENGINE AIR INTAKE, ADJACENT TO AIR CLEANER
MAP SENSOR (V8 N/A)	PI29	4-WAY / BLACK	INTAKE MANIFOLD, LOWER REAR
THROTTLE MOTOR (V8 N/A)	PI18	2-WAY / BLACK	ENGINE AIR INTAKE, FRONT
THROTTLE MOTOR RELAY	—	—	FRONT POWER DISTRIBUTION FUSE BOX - R4
TP SENSOR	PI26	4-WAY / BLACK	THROTTLE BODY, THROTTLE SHAFT
VVT SOLENOID VALVE 1	PI16	2-WAY / BLACK	RH CYLINDER HEAD, FRONT
VVT SOLENOID VALVE 2	PI17	2-WAY / BLACK	LH CYLINDER HEAD, FRONT

HARNESS IN-LINE CONNECTORS

Connector	Connector Description / Location	Location
FC12	14-WAY / GREY / FASCIA HARNESS TO FRONT HARNESS	BEHIND INSTRUMENT PANEL, PASSENGER SIDE
FC26	16-WAY / BLUE / CABIN HARNESS TO FASCIA HARNESS	BEHIND INSTRUMENT PANEL, DRIVER SIDE
FH1	20-WAY / BLACK / CABIN HARNESS TO FRONT HARNESS	RH 'A' POST, LOWER
FH3	16-WAY / BLUE / CABIN HARNESS TO FRONT HARNESS	LH 'A' POST
FP2	8-WAY / BLACK / CABIN HARNESS TO FUEL PUMP HARNESS	TOP OF FUEL TANK, RH SIDE
PI41	42-WAY / BLACK / ENGINE HARNESS TO VEHICLE HARNESSES	ENGINE COMPARTMENT, BULKHEAD, PASSENGER SIDE

GROUNDS

Ground	Location
PI40 (LHD)	ENGINE COMPARTMENT, BEHIND RH WHEEL ARCH LINER
PI40 (RHD)	ENGINE COMPARTMENT, BEHIND LH WHEEL ARCH LINER

FOR CONTROL MODULE PIN-OUT INFORMATION, UNFOLD PAGE TO LEFT.

Refer to the front of this book for detailed information and illustrations regarding the location and identification of harnesses, relays, fuses, grounds, control modules and control module pins.

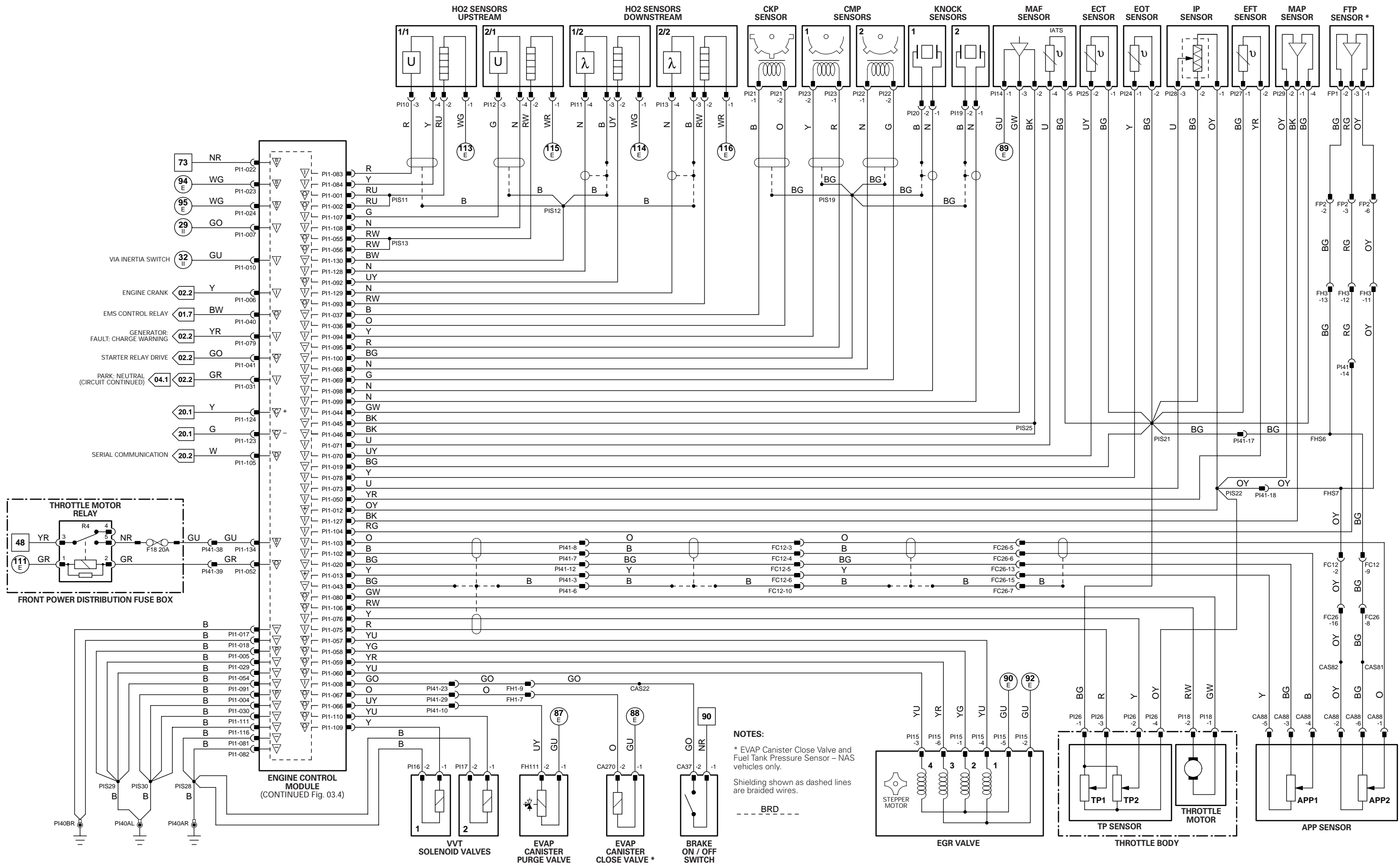

CONTROL MODULE PIN-OUT INFORMATION

Engine Control Module

Pin	Description and Characteristic
I P11-9	BRAKE CANCEL SWITCH: NORMALLY CLOSED / GROUND WHEN ACTIVATED
SS P11-12	SENSOR POWER SUPPLY 1: NOMINAL 5 V
SG P11-19	SENSOR GROUND 1: GROUND
O P11-27	FUEL PUMP DRIVE SIGNAL (TO RECM): PWM, 150 Hz, NORMAL POSITIVE DUTY CYCLE RANGE = 4% - 51%
O P11-34	AIR CONDITIONING COMPRESSOR CLUTCH RELAY DRIVE: TO ACTIVATE, ECM SWITCHES CIRCUIT TO GROUND
SS P11-47	SPEED CONTROL SWITCH REQUEST: STEPPED RESISTANCE
I P11-48	SPEED CONTROL SWITCHES SIGNAL GROUND: GROUND
O P11-51	COOLING FAN MODULE CONTROL: PWM, 140Hz, POSITIVE DUTY CYCLE RANGE 7% - 95%
O P11-61	IGNITION COIL ACTIVATE - CYLINDER 2: TO ACTIVATE, ECM SWITCHES CIRCUIT TO GROUND
O P11-62	IGNITION COIL ACTIVATE - CYLINDER 4: TO ACTIVATE, ECM SWITCHES CIRCUIT TO GROUND
O P11-63	IGNITION COIL ACTIVATE - CYLINDER 6: TO ACTIVATE, ECM SWITCHES CIRCUIT TO GROUND
O P11-64	IGNITION COIL ACTIVATE - CYLINDER 8: TO ACTIVATE, ECM SWITCHES CIRCUIT TO GROUND
O P11-87	IGNITION COIL ACTIVATE - CYLINDER 1: TO ACTIVATE, ECM SWITCHES CIRCUIT TO GROUND
O P11-88	IGNITION COIL ACTIVATE - CYLINDER 3: TO ACTIVATE, ECM SWITCHES CIRCUIT TO GROUND
O P11-89	IGNITION COIL ACTIVATE - CYLINDER 5: TO ACTIVATE, ECM SWITCHES CIRCUIT TO GROUND
O P11-90	IGNITION COIL ACTIVATE - CYLINDER 7: TO ACTIVATE, ECM SWITCHES CIRCUIT TO GROUND
O P11-112	FUEL INJECTOR DRIVE - CYLINDER 8: TO ACTIVATE, ECM SWITCHES CIRCUIT TO GROUND
O P11-113	FUEL INJECTOR DRIVE - CYLINDER 5: TO ACTIVATE, ECM SWITCHES CIRCUIT TO GROUND
O P11-114	FUEL INJECTOR DRIVE - CYLINDER 3: TO ACTIVATE, ECM SWITCHES CIRCUIT TO GROUND
O P11-115	FUEL INJECTOR DRIVE - CYLINDER 2: TO ACTIVATE, ECM SWITCHES CIRCUIT TO GROUND
O P11-117	FUEL INJECTOR DRIVE - CYLINDER 7: TO ACTIVATE, ECM SWITCHES CIRCUIT TO GROUND
O P11-118	FUEL INJECTOR DRIVE - CYLINDER 6: TO ACTIVATE, ECM SWITCHES CIRCUIT TO GROUND
O P11-119	FUEL INJECTOR DRIVE - CYLINDER 4: TO ACTIVATE, ECM SWITCHES CIRCUIT TO GROUND
O P11-120	FUEL INJECTOR DRIVE - CYLINDER 1: TO ACTIVATE, ECM SWITCHES CIRCUIT TO GROUND
I P11-121	AIR CONDITIONING PRESSURE SENSOR SIGNAL, NOMINAL 0 - 5 V: TRANSDUCER - VOLTAGE INCREASES AS PRESSURE INCREASES
I P11-131	IGNITION MONITOR BANK 1: PULSED SIGNAL, 3 PULSES PER ENGINE CYCLE
I P11-132	IGNITION MONITOR BANK 2: PULSED SIGNAL, 3 PULSES PER ENGINE CYCLE

Rear Electronic Control Module

Pin	Description and Characteristic
B+ CA100-8	IGNITION SWITCHED POWER SUPPLY (I): B+
B+ CA101-1	FUEL PUMP POWER SUPPLY: B+ WHEN FUEL PUMP RELAY IS ACTIVATED
SG CA101-2	LOGIC GROUND / FUEL PUMP DRIVE SHIELD: GROUND
B+ CA101-3	BATTERY POWER SUPPLY: B+
O CA101-11	FUEL PUMP SUPPLY VOLTAGE: B+
O CA101-12	FUEL PUMP ACTIVATE: GROUND (PWM)
S CA102-1	SCP +
S CA102-2	SCP -
I CA103-19	FUEL PUMP DRIVE SIGNAL: PWM, 150 Hz, NORMAL POSITIVE DUTY CYCLE RANGE = 4% - 51%

NOTE: Refer to the Appendix at the rear of this book for Network Messages.

The following abbreviations are used to represent values for Control Module Pin-Out data

I	Input	PG	Power Ground	C	CAN Network	D	Serial and Encoded Data
O	Output	SS	Sensor / Signal Supply V	S	SCP Network	V	Voltage (DC)
B+	Battery Voltage	SG	Sensor / Signal Ground	D2	D2B Network	PWM	Pulse Width Modulated

CAUTION: The information on this data page is furnished to aid the user in understanding circuit operation. THIS INFORMATION SHOULD BE USED FOR REFERENCE ONLY.

NOTE: The values listed are approximately those that can be expected at the control module connector pins with all circuit connections made and all components connected and fitted.

Fig. 03.4

COMPONENTS

Component	Connector(s)	Connector Description	Location
AIR CONDITIONING COMPRESSOR CLUTCH	PI49	2-WAY / BLACK	LOWER LH SIDE OF ENGINE
AIR CONDITIONING COMPRESSOR CLUTCH RELAY	—	—	FRONT POWER DISTRIBUTION FUSE BOX - R8
AIR CONDITIONING PRESSURE SENSOR	FH110	4-WAY / BLACK	ENGINE COMPARTMENT, LH SIDE, HIGH PRESSURE REFRIGERANT LINE, BETWEEN COMPRESSOR AND CONDENSER
BRAKE CANCEL SWITCH	CA36	2-WAY / GREY	TOP OF BRAKE PEDAL
COOLING FAN MODULE	FH108 FH109	2-WAY / BLACK 2-WAY / BLACK	ENGINE COMPARTMENT, RH FRONT, REARWARD OF RADIATOR
ENGINE CONTROL MODULE	PI1	134-WAY / BLACK	FRONT BULKHEAD, PASSENGER SIDE
FRONT POWER DISTRIBUTION FUSE BOX	—	—	ENGINE COMPARTMENT, RH SIDE
FUEL INJECTOR 1 (V8 N/A)	PI32	2-WAY / BLACK	FUEL RAIL / INTAKE MANIFOLD
FUEL INJECTOR 2 (V8 N/A)	PI36	2-WAY / BLACK	FUEL RAIL / INTAKE MANIFOLD
FUEL INJECTOR 3 (V8 N/A)	PI33	2-WAY / BLACK	FUEL RAIL / INTAKE MANIFOLD
FUEL INJECTOR 4 (V8 N/A)	PI37	2-WAY / BLACK	FUEL RAIL / INTAKE MANIFOLD
FUEL INJECTOR 5 (V8 N/A)	P34	2-WAY / BLACK	FUEL RAIL / INTAKE MANIFOLD
FUEL INJECTOR 6 (V8 N/A)	PI38	2-WAY / BLACK	FUEL RAIL / INTAKE MANIFOLD
FUEL INJECTOR 7 (V8 N/A)	PI35	2-WAY / BLACK	FUEL RAIL / INTAKE MANIFOLD
FUEL INJECTOR 8 (V8 N/A)	PI39	2-WAY / BLACK	FUEL RAIL / INTAKE MANIFOLD
FUEL PUMP 1	FP2 FP4	8-WAY / BLACK 4-WAY / BLACK	FUEL TANK, RH SIDE
FUEL PUMP RELAY	—	—	REAR POWER DISTRIBUTION FUSE BOX - R15
IGNITION CAPACITOR	PI54	2-WAY / BLACK	LH CYLINDER HEAD, REAR
IGNITION MODULE AND COIL 1	PI2	4-WAY / BLACK	RH CYLINDER HEAD
IGNITION MODULE AND COIL 2	PI6	4-WAY / BLACK	LH CYLINDER HEAD
IGNITION MODULE AND COIL 3	PI3	4-WAY / BLACK	RH CYLINDER HEAD
IGNITION MODULE AND COIL 4	PI7	4-WAY / BLACK	LH CYLINDER HEAD
IGNITION MODULE AND COIL 5	PI4	4-WAY / BLACK	RH CYLINDER HEAD
IGNITION MODULE AND COIL 6	PI8	4-WAY / BLACK	LH CYLINDER HEAD
IGNITION MODULE AND COIL 7	PI5	4-WAY / BLACK	RH CYLINDER HEAD
IGNITION MODULE AND COIL 8	PI9	4-WAY / BLACK	LH CYLINDER HEAD
REAR ELECTRONIC CONTROL MODULE	CA63 CA100 CA101 CA102 CA103	17-WAY / BLACK 12-WAY / BLACK 20-WAY / BLACK 22-WAY / BLACK 26-WAY / NATURAL	LUGGAGE COMPARTMENT, RH REAR
REAR POWER DISTRIBUTION FUSE BOX	—	—	LUGGAGE COMPARTMENT
STEERING WHEEL SPEED CONTROL SWITCHES	SQ2	6-WAY / BLACK	STEERING WHEEL

HARNES IN-LINE CONNECTORS

Connector	Connector Description / Location	Location
FC10	14-WAY / GREEN / FASCIA HARNESS TO FRONT HARNESS	BEHIND INSTRUMENT PANEL, RH SIDE
FC117	10-WAY / BLACK / STEERING WHEEL CASSETTE	STEERING COLUMN
FH1	20-WAY / BLACK / CABIN HARNESS TO FRONT HARNESS	RH 'A' POST, LOWER
FH3	16-WAY / BLUE / CABIN HARNESS TO FRONT HARNESS	LH 'A' POST
PI41	42-WAY / BLACK / ENGINE HARNESS TO VEHICLE HARNESSES	ENGINE COMPARTMENT, BULKHEAD, PASSENGER SIDE
PI42	8-WAY / BLACK / ENGINE HARNESS TO FRONT HARNESS	ENGINE COMPARTMENT, BULKHEAD, PASSENGER SIDE

GROUND S

Ground	Location
CA156	LUGGAGE COMPARTMENT, RH SIDE
FH22	ENGINE COMPARTMENT, BEHIND LH HEADLAMP
FH42	ENGINE COMPARTMENT, BEHIND RH HEADLAMP
FH95	ENGINE COMPARTMENT, BEHIND LH HEADLAMP (RADIATOR FAN GROUND)
PI51	ENGINE COMPARTMENT, ENGINE BLOCK

FOR CONTROL MODULE PIN-OUT INFORMATION, UNFOLD PAGE TO LEFT.

Refer to the front of this book for detailed information and illustrations regarding the location and identification of harnesses, relays, fuses, grounds, control modules and control module pins.

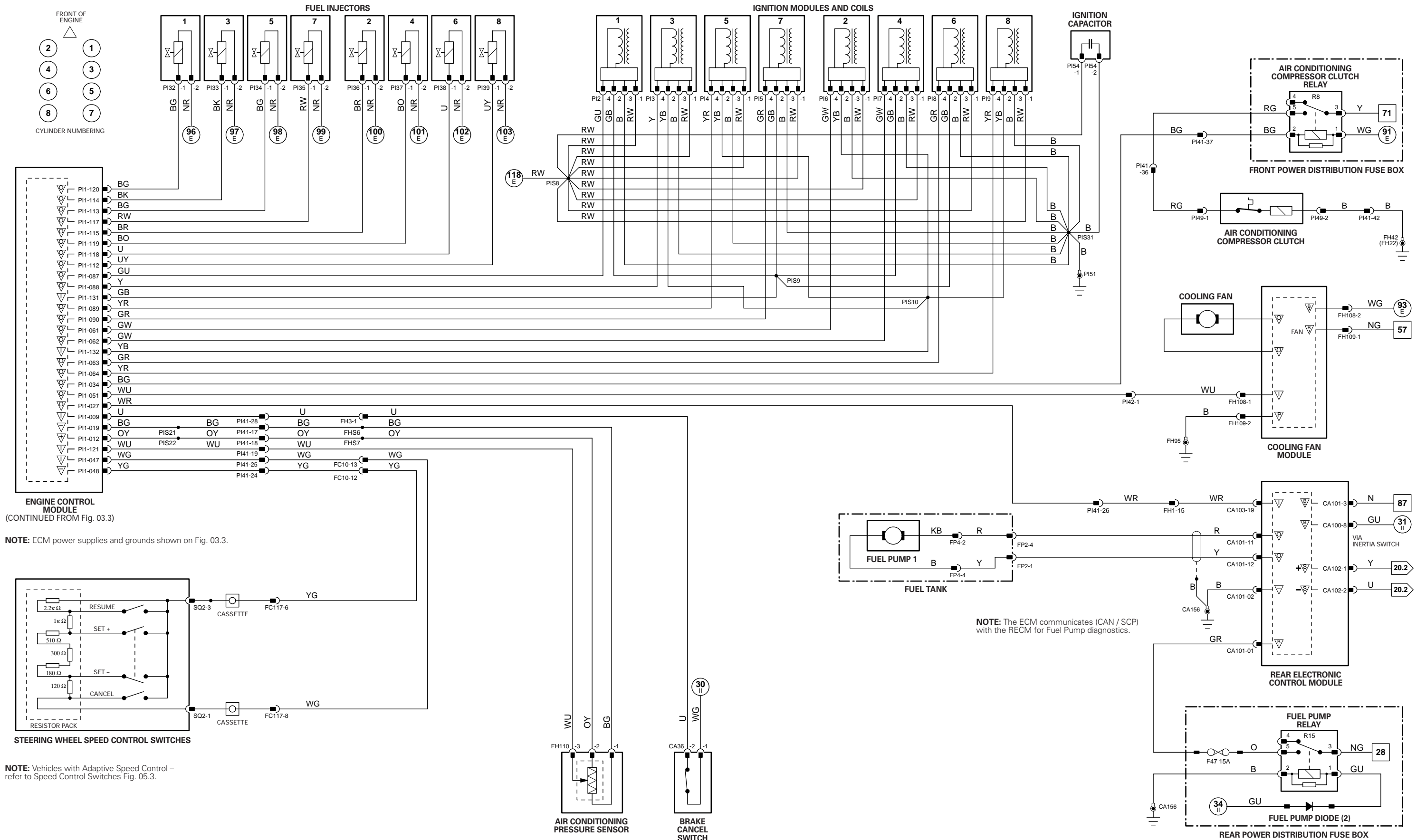

1 → 3 Fig. 01.1	4 → 76 Fig. 01.2	77 → 92 Fig. 01.3	1 → 14 Fig. 01.4	15 → 45 Fig. 01.5	46 → 80 Fig. 01.6	81 → 118 Fig. 01.7	Input	Battery Voltage	Sensor/Signal Supply V	CAN	D2B Network
							Output	Power Ground	Sensor/Signal Ground	SCP	Serial and Encoded Data

VARIANT: V8 N/A Vehicles
VIN RANGE: All
DATE OF ISSUE: June 2002

CONTROL MODULE PIN-OUT INFORMATION

Engine Control Module

Pin	Description and Characteristic
O P11-1	HO2 SENSOR HEATER CONTROL - 1/1: PWM, 1 CYCLE PER 128 mS, VARIABLE DUTY CYCLE
O P11-2	HO2 SENSOR HEATER CONTROL - 1/1: PWM, 1 CYCLE PER 128 mS, VARIABLE DUTY CYCLE
PG P11-4	POWER GROUND 1: GROUND
PG P11-5	POWER GROUND 2: GROUND
I P11-6	ENGINE CRANK: B+
I P11-7	IGNITION ON: B+
I P11-8	BRAKE ON / OFF SWITCH: NORMALLY OPEN / B+ WHEN ACTIVATED
I P11-10	INERTIA SWITCH: NORMALLY CLOSED / OPEN CIRCUIT WHEN ACTIVATED
SS P11-12	SENSOR POWER SUPPLY 1: NOMINAL 5 V
SS P11-13	SENSOR POWER SUPPLY 2: NOMINAL 5 V
SG P11-17	SMALL SIGNAL GROUND 1: GROUND
SG P11-18	SMALL SIGNAL GROUND 2: GROUND
SG P11-19	SENSOR GROUND 1: GROUND
SG P11-20	SENSOR GROUND 2: GROUND
B+ P11-22	BATTERY POWER SUPPLY: B+
B+ P11-23	EMS SWITCHED POWER SUPPLY 1: B+
B+ P11-24	EMS SWITCHED POWER SUPPLY 2: B+
SG P11-29	HO2 SENSOR HEATER GROUND - 1/1: GROUND
SG P11-30	HO2 SENSOR HEATER GROUND - 1/1: GROUND
I P11-31	AUTOMATIC - PARK / NEUTRAL SIGNAL: B+ WHEN ACTIVATED MANUAL, ROW - PARK / NEUTRAL SIGNAL: B+ WHEN IGNITION CRANK (III) MANUAL, NAS - CLUTCH PEDAL SAFETY SWITCH (PARK / NEUTRAL SIGNAL): B+ WHEN ACTIVATED
I P11-36	CRANKSHAFT SENSOR SIGNAL: PULSED SIGNAL, 70 PULSES PER ENGINE CYCLE
SG P11-37	CRANKSHAFT SENSOR SIGNAL GROUND: GROUND
O P11-40	EMS CONTROL RELAY DRIVE: TO ACTIVATE, ECM SWITCHES CIRCUIT TO GROUND
O P11-41	STARTER RELAY DRIVE: TO ACTIVATE, ECM SWITCHES CIRCUIT TO GROUND
SG P11-43	TP AND APP SIGNALS SHIELD: GROUND
I P11-44	MASS AIR FLOW SENSOR SIGNAL: NOMINAL 0 - 5 V BY ENGINE OPERATING CONDITION
SG P11-45	MASS AIR FLOW SENSOR GROUND: GROUND
SG P11-46	MASS AIR FLOW SENSOR GROUND: GROUND
I P11-50	ENGINE FUEL TEMPERATURE SENSOR SIGNAL, NOMINAL 0 - 5 V: NTC SENSOR - VOLTAGE DECREASES AS TEMPERATURE INCREASES
O P11-52	THROTTLE MOTOR RELAY DRIVE: TO ACTIVATE, ECM SWITCHES CIRCUIT TO GROUND
SG P11-54	THROTTLE MOTOR GROUND: GROUND
O P11-55	HO2 SENSOR HEATER CONTROL - 2/1: PWM, 1 CYCLE PER 128 mS, VARIABLE DUTY CYCLE
O P11-56	HO2 SENSOR HEATER CONTROL - 2/1: PWM, 1 CYCLE PER 128 mS, VARIABLE DUTY CYCLE
O P11-57	EGR DRIVE 1: B+; EGR DRIVE 1, 2, 3 AND 4 ARE OPERATED IN TURN
O P11-58	EGR DRIVE 2: B+; EGR DRIVE 1, 2, 3 AND 4 ARE OPERATED IN TURN
O P11-59	EGR DRIVE 3: B+; EGR DRIVE 1, 2, 3 AND 4 ARE OPERATED IN TURN
O P11-60	EGR DRIVE 4: B+; EGR DRIVE 1, 2, 3 AND 4 ARE OPERATED IN TURN
O P11-66	EVAP CANISTER PURGE VALVE DRIVE: PWM, 10 Hz, POSITIVE DUTY CYCLE RANGE 7% - 100%
O P11-67	EVAP CANISTER CLOSE VALVE DRIVE: TO CLOSE, ECM SWITCHES CIRCUIT TO GROUND
I P11-68	BANK 2 CAMSHAFT SENSOR SIGNAL: PULSED SIGNAL, 4 PULSES PER ENGINE CYCLE
SG P11-69	BANK 2 CAMSHAFT SENSOR GROUND: GROUND
I P11-70	ENGINE COOLANT TEMPERATURE SENSOR SIGNAL, NOMINAL 0 - 5 V: NTC SENSOR - VOLTAGE DECREASES AS TEMPERATURE INCREASES
I P11-71	INTAKE AIR TEMPERATURE SENSOR SIGNAL, NOMINAL 0 - 5 V: NTC SENSOR - VOLTAGE DECREASES AS TEMPERATURE INCREASES
I P11-72	INTAKE AIR TEMPERATURE SENSOR 2 SIGNAL, NOMINAL 0 - 5 V: NTC SENSOR - VOLTAGE DECREASES AS TEMPERATURE INCREASES
I P11-73	INJECTION PRESSURE SENSOR SIGNAL, NOMINAL 0 - 5 V: POTENTIOMETER - VOLTAGE INCREASES AS PRESSURE INCREASES
I P11-75	THROTTLE POSITION SENSOR 1 SIGNAL: IDLE = 0.60 V; FULL THROTTLE = 4.30 V
I P11-76	THROTTLE POSITION SENSOR 2 SIGNAL: IDLE = 1.48 V; FULL THROTTLE = 4.40 V
I P11-78	ENGINE OIL TEMPERATURE SENSOR SIGNAL, NOMINAL 0 - 5 V: NTC SENSOR - VOLTAGE DECREASES AS TEMPERATURE INCREASES
I P11-79	GENERATOR FAULT: CHARGE WARNING
O P11-80	THROTTLE MOTOR DRIVE: B+ TO ACTIVATE MOTOR
SG P11-81	HO2 SENSOR HEATER GROUND - 2/1: GROUND
SG P11-82	HO2 SENSOR HEATER GROUND - 2/1: GROUND
I P11-83	HO2 SENSOR 1/1 SIGNAL: VARIABLE CURRENT
I P11-84	HO2 SENSOR 1/1 SIGNAL: CONSTANT CURRENT
SG P11-91	HO2 SENSOR HEATERS 1/2, 2/2 GROUND: GROUND
O P11-92	HO2 SENSOR HEATER CONTROL - 1/2: PWM, 1 CYCLE PER 256 mS, POSITIVE DUTY CYCLE RANGE 0 mS = 0%, 77 mS = 30%, 256 mS = 100%
O P11-93	HO2 SENSOR HEATER CONTROL - 2/2: PWM, 1 CYCLE PER 256 mS, POSITIVE DUTY CYCLE RANGE 0 mS = 0%, 77 mS = 30%, 256 mS = 100%
I P11-94	BANK 1 CAMSHAFT SENSOR SIGNAL: PULSED SIGNAL, 4 PULSES PER ENGINE CYCLE
SG P11-95	BANK 1 CAMSHAFT SENSOR GROUND: GROUND
I P11-98	BANK 1 KNOCK SENSOR SIGNAL: VARIABLE VOLTAGE DEPENDENT ON ENGINE VIBRATION
I P11-99	BANK 2 KNOCK SENSOR SIGNAL: VARIABLE VOLTAGE DEPENDENT ON ENGINE VIBRATION
SG P11-100	SENSOR SHIELD: GROUND
I P11-102	ACCELERATOR PEDAL POSITION SENSOR 1 SIGNAL: FOOT OFF = 0.75 V; FULLY DEPRESSED = 3.40 V (AUTO) 3.20 (MAN)
I P11-103	ACCELERATOR PEDAL POSITION SENSOR 2 SIGNAL: FOOT OFF = 3.38 V; FULLY DEPRESSED = 2.05 V (AUTO) 2.14 V (MAN)
I P11-104	FUEL TANK PRESSURE SENSOR SIGNAL, NOMINAL 0 - 5 V: VOLTAGE INCREASES AS PRESSURE INCREASES
D P11-105	SERIAL DATA LINK: SERIAL COMMUNICATION
O P11-106	THROTTLE MOTOR DRIVE: B+ TO ACTIVATE MOTOR
I P11-107	HO2 SENSOR 2/1 SIGNAL: VARIABLE CURRENT
I P11-108	HO2 SENSOR 2/1 SIGNAL: CONSTANT CURRENT
SG P11-111	FUEL INJECTORS 2, 3, 5, 8 GROUND: GROUND
SG P11-116	FUEL INJECTORS 1, 4, 6, 7 GROUND: GROUND
C P11-123	CAN -
C P11-124	CAN +
I P11-127	MAP SENSOR SIGNAL, NOMINAL 0 - 5 V: VOLTAGE INCREASES AS MANIFOLD ABSOLUTE PRESSURE INCREASES
I P11-128	HO2 SENSOR 1/2 SIGNAL, NOMINAL 1 V SWING: 0.1 - 0.9 V SWING
I P11-129	HO2 SENSOR 2/2 SIGNAL, NOMINAL 1 V SWING: 0.1 - 0.9 V SWING
SG P11-130	HO2 SENSORS SHIELD: GROUND
B+ P11-134	THROTTLE MOTOR POWER SUPPLY: B+ WHEN RELAY ACTIVATED

NOTE: Refer to the Appendix at the rear of this book for Network Messages.

The following abbreviations are used to represent values for Control Module Pin-Out data

I	Input	PG	Power Ground	C	CAN Network	D	Serial and Encoded Data
O	Output	SS	Sensor / Signal Supply V	S	SCP Network	V	Voltage (DC)
B+	Battery Voltage	SG	Sensor / Signal Ground	D2	D2B Network	PWM	Pulse Width Modulated

CAUTION: The information on this data page is furnished to aid the user in understanding circuit operation. THIS INFORMATION SHOULD BE USED FOR REFERENCE ONLY.

NOTE: The values listed are approximately those that can be expected at the control module connector pins with all circuit connections made and all components connected and fitted.

Fig. 03.5

COMPONENTS

Component	Connector(s)	Connector Description	Location
APP SENSOR	CA88	6-WAY / BLACK	TOP OF ACCELERATOR PEDAL
BRAKE ON / OFF SWITCH	CA37	2-WAY / GREEN	TOP OF BRAKE PEDAL
CKP SENSOR (V8)	PI21	2-WAY / BLACK	ENGINE UNDER SIDE, FORWARD OF BELL HOUSING
CMP SENSOR 1 (V8)	PI23	2-WAY / BLACK	BANK 1 (RH) CAMSHAFT COVER, FRONT
CMP SENSOR 2 (V8)	PI22	2-WAY / BLACK	BANK 2 (LH) CAMSHAFT COVER, FRONT
ECT SENSOR	PI25	2-WAY / BLACK	ENGINE VEE, COOLANT OUTLET CASTING
EFT SENSOR (V8)	PI27	2-WAY / BLACK	FUEL RAIL, RH REAR
EGR VALVE (V8 SC)	PI15	6-WAY / BLACK	INTAKE MANIFOLD, REAR
ENGINE CONTROL MODULE	PI1	134-WAY / BLACK	FRONT BULKHEAD, PASSENGER SIDE
EOT SENSOR	PI24	2-WAY / BLACK	ADJACENT TO OIL FILTER
EVAP CANISTER CLOSE VALVE	CA270	2-WAY / BLACK	ABOVE REAR AXLE (FUEL TANK COMPONENTS)
EVAP CANISTER PURGE VALVE	FH111	2-WAY / BLACK	ENGINE COMPARTMENT, LH SIDE, ADJACENT TO SUSPENSION TURRET
FRONT POWER DISTRIBUTION FUSE BOX	—	—	ENGINE COMPARTMENT, RH SIDE
FTP SENSOR	FP1	3-WAY / BLACK	FUEL TANK PIPING, LH SIDE (UNDER ACCESS PLATE)
HO2 SENSOR DOWNSTREAM 1/2	PI11	4-WAY / BLACK	RH EXHAUST, TOP OF CATALYST
HO2 SENSOR DOWNSTREAM 2/2	PI13	4-WAY / BLACK	LH EXHAUST, TOP OF CATALYST
HO2 SENSOR UPSTREAM 1/1	PI10	4-WAY / BLACK	RH EXHAUST, CATALYST CENTER
HO2 SENSOR UPSTREAM 2/1	PI12	4-WAY / BLACK	RH EXHAUST, CATALYST CENTER
IAT SENSOR 2	PI43	2-WAY / BLACK	INTAKE MANIFOLD, RH SIDE, REAR
IP SENSOR (V8 SIC)	PI28	3-WAY / BLACK	FUEL RAIL, LH REAR
KNOCK SENSOR 1 (V8)	PI20	2-WAY / BLACK	ENGINE VEE, BANK 1
KNOCK SENSOR 2 (V8)	PI19	2-WAY / BLACK	ENGINE VEE, BANK 2
MAF SENSOR	PI14	5-WAY / BLACK	ENGINE AIR INTAKE, ADJACENT TO AIR CLEANER
MAP SENSOR (V8 SC)	PI29	4-WAY / BLACK	INTAKE MANIFOLD, REAR, BELOW THROTTLE ASSEMBLY
THROTTLE MOTOR (V8 SC)	PI18	2-WAY / BLACK	ENGINE AIR INTAKE, REAR
THROTTLE MOTOR RELAY	—	—	FRONT POWER DISTRIBUTION FUSE BOX - R4
TP SENSOR	PI26	4-WAY / BLACK	THROTTLE BODY, THROTTLE SHAFT

HARNES IN-LINE CONNECTORS

Connector	Connector Description / Location	Location
FC12	14-WAY / GREY / FASCIA HARNESS TO FRONT HARNESS	BEHIND INSTRUMENT PANEL, PASSENGER SIDE
FC26	16-WAY / BLUE / CABIN HARNESS TO FASCIA HARNESS	BEHIND INSTRUMENT PANEL, DRIVER SIDE
FH1	20-WAY / BLACK / CABIN HARNESS TO FRONT HARNESS	RH 'A' POST, LOWER
FH3	16-WAY / BLUE / CABIN HARNESS TO FRONT HARNESS	LH 'A' POST
FP2	8-WAY / BLACK / CABIN HARNESS TO FUEL PUMP HARNESS	TOP OF FUEL TANK, RH SIDE
PI41	42-WAY / BLACK / ENGINE HARNESS TO VEHICLE HARNESSES	ENGINE COMPARTMENT, BULKHEAD, PASSENGER SIDE

GROUND S

Ground	Location
PI40 (LHD)	ENGINE COMPARTMENT, BEHIND RH WHEEL ARCH LINER
PI40 (RHD)	ENGINE COMPARTMENT, BEHIND LH WHEEL ARCH LINER

FOR CONTROL MODULE PIN-OUT INFORMATION, UNFOLD PAGE TO LEFT.

Refer to the front of this book for detailed information and illustrations regarding the location and identification of harnesses, relays, fuses, grounds, control modules and control module pins.

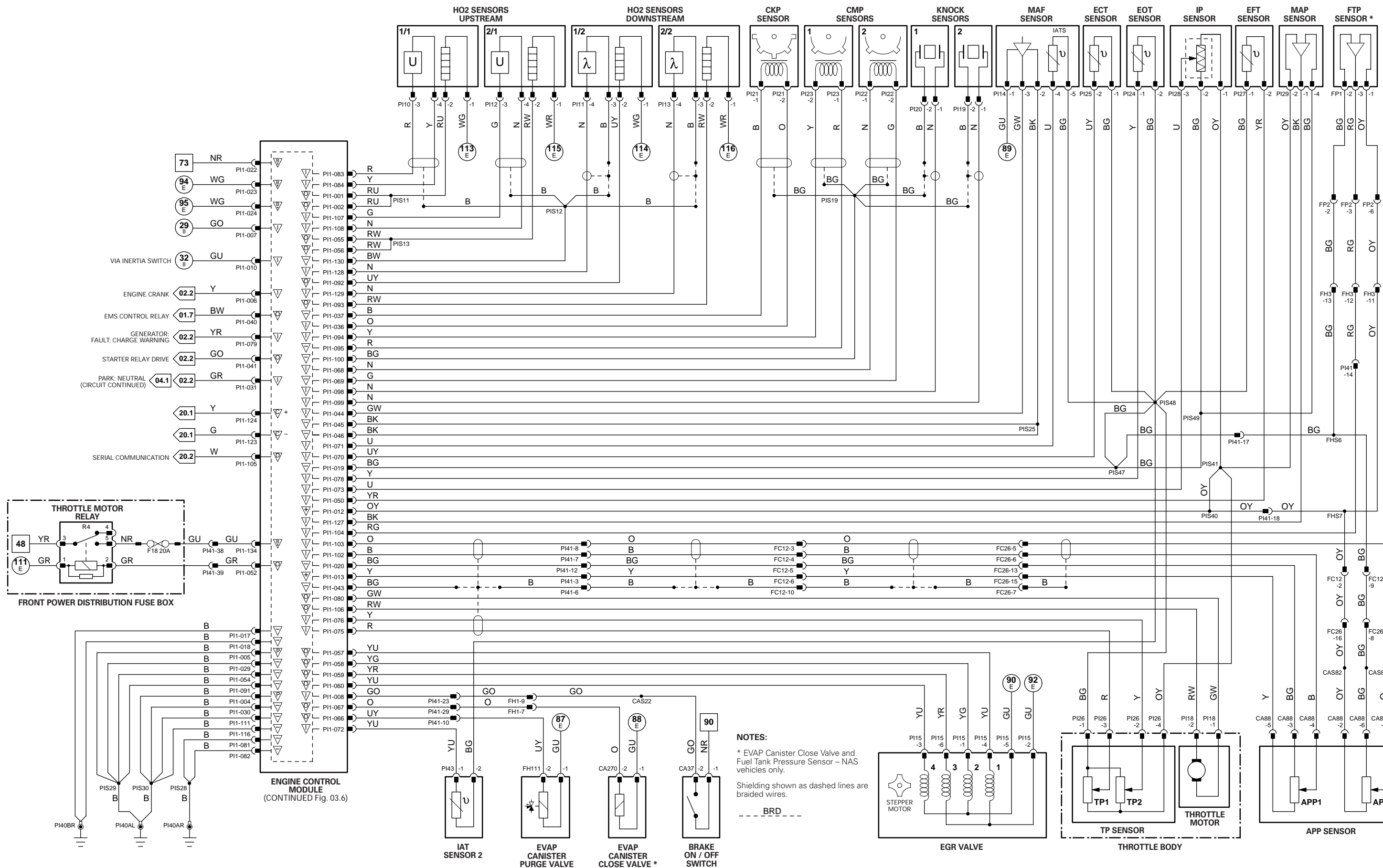

NOTES:

* EVAP Canister Close Valve and Fuel Tank Pressure Sensor - NAS vehicles only.

Shielding shown as dashed lines are braided wires.

--- BRD ---

CONTROL MODULE PIN-OUT INFORMATION

Engine Control Module

Pin	Description and Characteristic
I P11-9	BRAKE CANCEL SWITCH: NORMALLY CLOSED / GROUND WHEN ACTIVATED
I P11-11	FUEL PUMP 2 MODULE MONITOR: 1Hz FREQUENCY: 50% DUTY CYCLE = OK, 25% OR 75% DUTY CYCLE = FAULT
SS P11-12	SENSOR POWER SUPPLY 1: NOMINAL 5 V
O P11-14	AIR CLEANER SOLENOID VALVE DRIVE: TO ACTIVATE, ECM SWITCHES CIRCUIT TO GROUND
SG P11-19	SENSOR GROUND 1: GROUND
O P11-27	FUEL PUMP DRIVE SIGNAL (TO RECM): PWM, 150 Hz, NORMAL POSITIVE DUTY CYCLE RANGE = 4% - 51%
O P11-34	AIR CONDITIONING COMPRESSOR CLUTCH RELAY DRIVE: TO ACTIVATE, ECM SWITCHES CIRCUIT TO GROUND
SS P11-47	SPEED CONTROL SWITCH REQUEST: STEPPED RESISTANCE
I P11-48	SPEED CONTROL SWITCHES SIGNAL GROUND: GROUND
O P11-51	COOLING FAN MODULE CONTROL: PWM, 140Hz, POSITIVE DUTY CYCLE RANGE 7% - 95%
O P11-53	FUEL PUMP 2 DRIVE (TO FUEL PUMP 2 MODULE): PWM, 150 Hz, NORMAL POSITIVE DUTY CYCLE RANGE = 4% - 51%
O P11-61	IGNITION COIL ACTIVATE - CYLINDER 2: TO ACTIVATE, ECM SWITCHES CIRCUIT TO GROUND
O P11-62	IGNITION COIL ACTIVATE - CYLINDER 4: TO ACTIVATE, ECM SWITCHES CIRCUIT TO GROUND
O P11-63	IGNITION COIL ACTIVATE - CYLINDER 6: TO ACTIVATE, ECM SWITCHES CIRCUIT TO GROUND
O P11-64	IGNITION COIL ACTIVATE - CYLINDER 8: TO ACTIVATE, ECM SWITCHES CIRCUIT TO GROUND
O P11-87	IGNITION COIL ACTIVATE - CYLINDER 1: TO ACTIVATE, ECM SWITCHES CIRCUIT TO GROUND
O P11-88	IGNITION COIL ACTIVATE - CYLINDER 3: TO ACTIVATE, ECM SWITCHES CIRCUIT TO GROUND
O P11-89	IGNITION COIL ACTIVATE - CYLINDER 5: TO ACTIVATE, ECM SWITCHES CIRCUIT TO GROUND
O P11-90	IGNITION COIL ACTIVATE - CYLINDER 7: TO ACTIVATE, ECM SWITCHES CIRCUIT TO GROUND
O P11-112	FUEL INJECTOR DRIVE - CYLINDER 8: TO ACTIVATE, ECM SWITCHES CIRCUIT TO GROUND
O P11-113	FUEL INJECTOR DRIVE - CYLINDER 5: TO ACTIVATE, ECM SWITCHES CIRCUIT TO GROUND
O P11-114	FUEL INJECTOR DRIVE - CYLINDER 3: TO ACTIVATE, ECM SWITCHES CIRCUIT TO GROUND
O P11-115	FUEL INJECTOR DRIVE - CYLINDER 2: TO ACTIVATE, ECM SWITCHES CIRCUIT TO GROUND
O P11-117	FUEL INJECTOR DRIVE - CYLINDER 7: TO ACTIVATE, ECM SWITCHES CIRCUIT TO GROUND
O P11-118	FUEL INJECTOR DRIVE - CYLINDER 6: TO ACTIVATE, ECM SWITCHES CIRCUIT TO GROUND
O P11-119	FUEL INJECTOR DRIVE - CYLINDER 4: TO ACTIVATE, ECM SWITCHES CIRCUIT TO GROUND
O P11-120	FUEL INJECTOR DRIVE - CYLINDER 1: TO ACTIVATE, ECM SWITCHES CIRCUIT TO GROUND
I P11-121	AIR CONDITIONING PRESSURE SENSOR SIGNAL, NOMINAL 0 - 5 V: TRANSDUCER - VOLTAGE INCREASES AS PRESSURE INCREASES
I P11-131	IGNITION MONITOR BANK 1: PULSED SIGNAL, 3 PULSES PER ENGINE CYCLE
I P11-132	IGNITION MONITOR BANK 2: PULSED SIGNAL, 3 PULSES PER ENGINE CYCLE

Rear Control Module

Pin	Description and Characteristic
B+ CA100-8	IGNITION SWITCHED POWER SUPPLY (I): B+
B+ CA101-1	FUEL PUMP POWER SUPPLY: B+ WHEN FUEL PUMP RELAY IS ACTIVATED
SG CA101-2	LOGIC GROUND / FUEL PUMP DRIVE SHIELD: GROUND
B+ CA101-3	BATTERY POWER SUPPLY: B+
O CA101-11	FUEL PUMP SUPPLY VOLTAGE: B+
O CA101-12	FUEL PUMP ACTIVATE: GROUND (PWM)
S CA102-1	SCP +
S CA102-2	SCP -
I CA103-19	FUEL PUMP DRIVE SIGNAL: PWM, 150 Hz, NORMAL POSITIVE DUTY CYCLE RANGE = 4% - 51%

NOTE: Refer to the Appendix at the rear of this book for Network Messages.

Fig. 03.6

COMPONENTS

Component	Connector(s)	Connector Description	Location
AIR CLEANER SOLENOID VALVE	FH10	2-WAY / BLACK	AIR CLEANER HOUSING
AIR CONDITIONING COMPRESSOR CLUTCH	PI49	2-WAY / BLACK	LOWER LH SIDE OF ENGINE
AIR CONDITIONING COMPRESSOR CLUTCH RELAY	—	—	FRONT POWER DISTRIBUTION FUSE BOX - R8
AIR CONDITIONING PRESSURE SENSOR	FH110	4-WAY / BLACK	ENGINE COMPARTMENT, LH SIDE, HIGH PRESSURE REFRIGERANT LINE, BETWEEN COMPRESSOR AND CONDENSER
BRAKE CANCEL SWITCH	CA36	2-WAY / GREY	TOP OF BRAKE PEDAL
COOLING FAN MODULE	FH108 FH109	2-WAY / BLACK 2-WAY / BLACK	ENGINE COMPARTMENT, RH FRONT, REARWARD OF RADIATOR
ENGINE CONTROL MODULE	PI1	134-WAY / BLACK	FRONT BULKHEAD, PASSENGER SIDE
FRONT POWER DISTRIBUTION FUSE BOX	—	—	ENGINE COMPARTMENT, RH SIDE
FUEL INJECTOR 1 (V8 SC)	IS1	2-WAY / BLACK	FUEL RAIL / INTAKE MANIFOLD
FUEL INJECTOR 2 (V8 SC)	IS7	2-WAY / BLACK	FUEL RAIL / INTAKE MANIFOLD
FUEL INJECTOR 3 (V8 SC)	IS2	2-WAY / BLACK	FUEL RAIL / INTAKE MANIFOLD
FUEL INJECTOR 4 (V8 SC)	IS8	2-WAY / BLACK	FUEL RAIL / INTAKE MANIFOLD
FUEL INJECTOR 5 (V8 SC)	IS3	2-WAY / BLACK	FUEL RAIL / INTAKE MANIFOLD
FUEL INJECTOR 6 (V8 SC)	IS9	2-WAY / BLACK	FUEL RAIL / INTAKE MANIFOLD
FUEL INJECTOR 7 (V8 SC)	IS4	2-WAY / BLACK	FUEL RAIL / INTAKE MANIFOLD
FUEL INJECTOR 8 (V8 SC)	IS10	2-WAY / BLACK	FUEL RAIL / INTAKE MANIFOLD
FUEL PUMP 1	FP2 FP4	8-WAY / BLACK 4-WAY / BLACK	FUEL TANK, RH SIDE
FUEL PUMP 2	FP2 FP3	8-WAY / BLACK 4-WAY / BLACK	FUEL TANK, LH SIDE
FUEL PUMP 2 MODULE	CA283	10-WAY / BLACK	LUGGAGE COMPARTMENT, RH REAR
FUEL PUMP RELAY	—	—	REAR POWER DISTRIBUTION FUSE BOX - R15
IGNITION CAPACITOR	PI54	2-WAY / BLACK	LH CYLINDER HEAD, REAR
IGNITION MODULE AND COIL 1	PI2	4-WAY / BLACK	RH CYLINDER HEAD
IGNITION MODULE AND COIL 2	PI6	4-WAY / BLACK	LH CYLINDER HEAD
IGNITION MODULE AND COIL 3	PI3	4-WAY / BLACK	RH CYLINDER HEAD
IGNITION MODULE AND COIL 4	PI7	4-WAY / BLACK	LH CYLINDER HEAD
IGNITION MODULE AND COIL 5	PI4	4-WAY / BLACK	RH CYLINDER HEAD
IGNITION MODULE AND COIL 6	PI8	4-WAY / BLACK	LH CYLINDER HEAD
IGNITION MODULE AND COIL 7	PI5	4-WAY / BLACK	RH CYLINDER HEAD
IGNITION MODULE AND COIL 8	PI9	4-WAY / BLACK	LH CYLINDER HEAD
INTERCOOLER PUMP	CP2	2-WAY / BLACK	ENGINE COMPARTMENT, RH SIDE, ADJACENT TO RADIATOR
REAR ELECTRONIC CONTROL MODULE	CA63 CA100 CA101 CA102 CA103	17-WAY / BLACK 12-WAY / BLACK 20-WAY / BLACK 22-WAY / BLACK 26-WAY / NATURAL	LUGGAGE COMPARTMENT, RH REAR
REAR POWER DISTRIBUTION FUSE BOX	—	—	LUGGAGE COMPARTMENT
STEERING WHEEL SPEED CONTROL SWITCHES	SO2	6-WAY / BLACK	STEERING WHEEL

HARNESS IN-LINE CONNECTORS

Connector	Connector Description / Location	Location
CP1	10-WAY / BLACK / INTERCOOLER PUMP LINK LEAD	ENGINE COMPARTMENT, RH FRONT, ADJACENT TO RADIATOR
FC10	14-WAY / GREEN / FASCIA HARNESS TO FRONT HARNESS	BEHIND INSTRUMENT PANEL, RH SIDE
FC117	10-WAY / BLACK / STEERING WHEEL CASSETTE	STEERING COLUMN
FH1	20-WAY / BLACK / CABIN HARNESS TO FRONT HARNESS	RH 'A' POST, LOWER
FH2	16-WAY / GREY / CABIN HARNESS TO FRONT HARNESS	RH 'A' POST, LOWER
FH3	16-WAY / BLUE / CABIN HARNESS TO FRONT HARNESS	LH 'A' POST
ISS	6-WAY / BLACK / ENGINE HARNESS TO FUEL INJECTOR LINK	ENGINE, LH REAR
IS6	6-WAY / BLACK / ENGINE HARNESS TO FUEL INJECTOR LINK	ENGINE, RH REAR
PI41	42-WAY / BLACK / ENGINE HARNESS TO VEHICLE HARNESSES	ENGINE COMPARTMENT, BULKHEAD, PASSENGER SIDE
PI42	8-WAY / BLACK / ENGINE HARNESS TO FRONT HARNESS	ENGINE COMPARTMENT, BULKHEAD, PASSENGER SIDE

GROUNDINGS

Ground	Location
CA156	LUGGAGE COMPARTMENT, RH SIDE
FH22	ENGINE COMPARTMENT, BEHIND LH HEADLAMP
FH42	ENGINE COMPARTMENT, BEHIND RH HEADLAMP
FH95	ENGINE COMPARTMENT, BEHIND LH HEADLAMP (RADIATOR FAN GROUND)
PI51	ENGINE COMPARTMENT, ENGINE BLOCK

FOR CONTROL MODULE PIN-OUT INFORMATION, UNFOLD PAGE TO LEFT.

The following abbreviations are used to represent values for Control Module Pin-Out data

I	Input	PG	Power Ground	C	CAN Network	D	Serial and Encoded Data
O	Output	SS	Sensor / Signal Supply V	S	SCP Network	V	Voltage (DC)
B+	Battery Voltage	SG	Sensor / Signal Ground	D2	D2B Network	PWM	Pulse Width Modulated

CAUTION: The information on this data page is furnished to aid the user in understanding circuit operation. THIS INFORMATION SHOULD BE USED FOR REFERENCE ONLY.

NOTE: The values listed are approximately those that can be expected at the control module connector pins with all circuit connections made and all components connected and fitted.

Refer to the front of this book for detailed information and illustrations regarding the location and identification of harnesses, relays, fuses, grounds, control modules and control module pins.

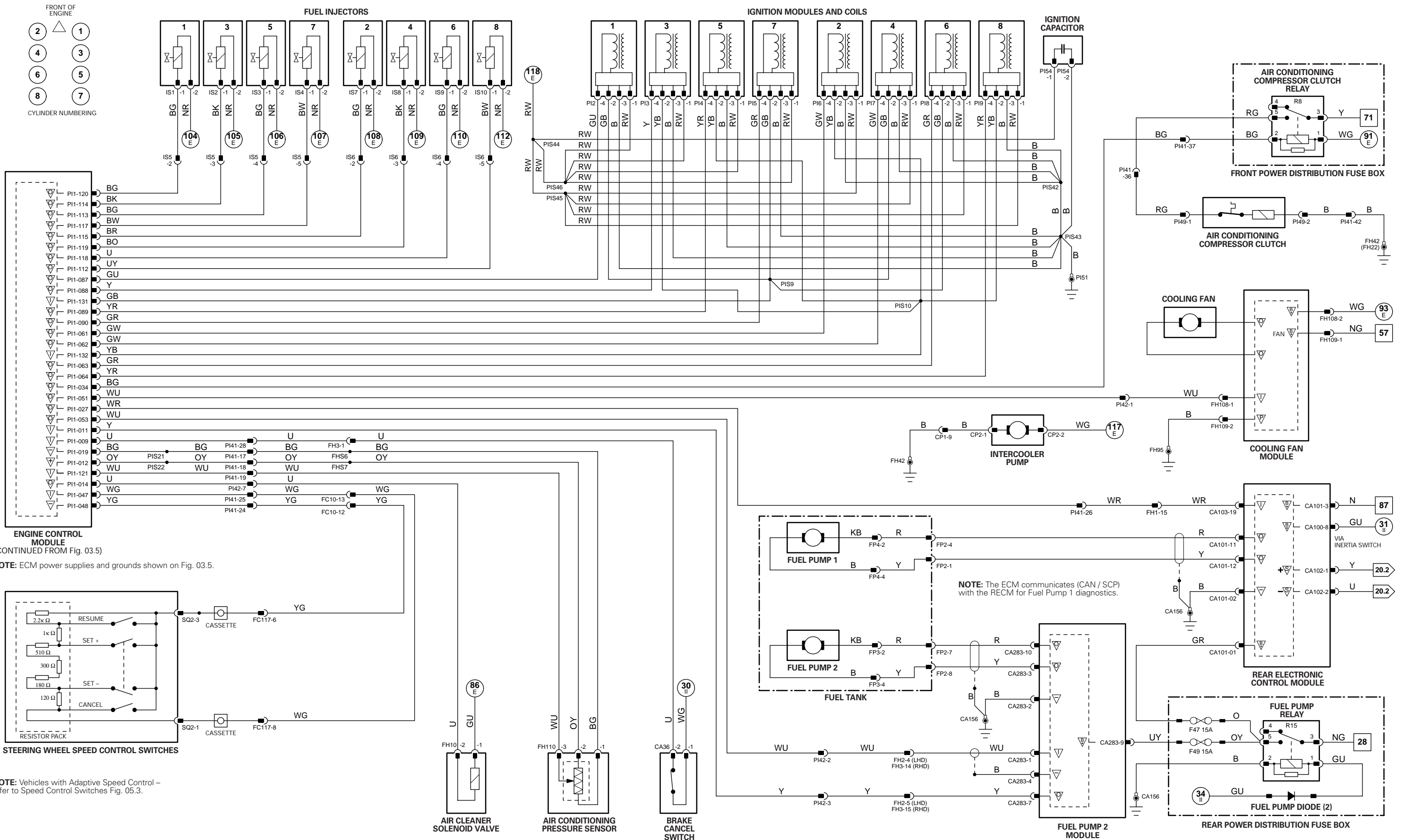

1 → 3 Fig. 01.1	4 → 76 Fig. 01.2	77 → 92 Fig. 01.3	1 → 14 Fig. 01.4	15 → 45 Fig. 01.5	46 → 80 Fig. 01.6	81 → 118 Fig. 01.7	Input	Battery Voltage	Sensor/Signal Supply V	CAN	D2B Network
			Output	Power Ground	Sensor/Signal Ground	SCP	Serial and Encoded Data				

VARIANT: V8 SC Vehicles
VIN RANGE: All
DATE OF ISSUE: June 2002

CONTROL MODULE PIN-OUT INFORMATION

Parking Brake Control Module

Pin	Description and Characteristic
I CA242-3	IN-GEAR SWITCH (NORMALLY OPEN): OPEN CIRCUIT / GROUND
SS CA242-8	SIGNAL SUPPLY VOLTAGE: NOMINAL 5 V
SG CA242-9	SIGNAL GROUND: GROUND
I CA242-11	CLUTCH PEDAL POSITION SENSOR FEEDBACK SIGNAL: VARIABLE VOLTAGE

Engine Control Module

Pin	Description and Characteristic
I P11-31	AUTOMATIC - PARK / NEUTRAL SIGNAL: B+ WHEN ACTIVATED MANUAL, ROW - PARK / NEUTRAL SIGNAL: B+ WHEN IGNITION CRANK (III) MANUAL, NAS - CLUTCH PEDAL SAFETY SWITCH (PARK / NEUTRAL SIGNAL): B+ WHEN ACTIVATED
I P11-33	CLUTCH CANCEL SWITCH: NORMALLY CLOSED / GROUND WHEN ACTIVATED

Transmission Control Module

Pin	Description and Characteristic
C GB2-2	CAN -
C GB2-6	CAN +
B+ GB2-9	IGNITION SWITCHED POWER SUPPLY: B+
O GB2-10	PARK / NEUTRAL SIGNAL: GROUND WHEN ACTIVATED
PG GB2-13	POWER GROUND: GROUND
B+ GB2-14	BATTERY POWER SUPPLY: B+
PG GB2-16	POWER GROUND: GROUND

NOTE: Refer to the Appendix at the rear of this book for Network Messages.

Fig. 04.1

COMPONENTS

Component	Connector(s)	Connector Description	Location
CLUTCH CANCEL SWITCH	CA285 (LHD) CA291 (RHD)	2-WAY / BLACK 5-WAY / BLACK	TOP OF CLUTCH PEDAL (TOP SWITCH)
CLUTCH PEDAL POSITION SENSOR	CA287	6-WAY / BLACK	TOP OF CLUTCH PEDAL
CLUTCH PEDAL SAFETY SWITCH	CA286	2-WAY / BLACK	TOP OF CLUTCH PEDAL (BOTTOM SWITCH)
ENGINE CONTROL MODULE	PI1	134-WAY / BLACK	FRONT BULKHEAD, PASSENGER SIDE
IGNITION SWITCH	FC18	7-WAY / BLACK	STEERING COLUMN COWLING
J GATE MODULE	CA245	16-WAY / BLACK	J GATE ASSEMBLY
NEUTRAL SWITCH	GB4	2-WAY / BLACK	TRANSMISSION, LH REAR
PARKING BRAKE CONTROL MODULE	CA241 CA242	4-WAY / BLACK 12-WAY / BLACK	LUGGAGE COMPARTMENT, RH REAR
REVERSE SWITCH	GB5	2-WAY / BLACK	TRANSMISSION, LH REAR
TRANSMISSION CAPACITOR (V6)	GB17	2-WAY / BLACK	ENGINE COMPARTMENT, BULKHEAD
TRANSMISSION CAPACITOR (V8)	PI59	2-WAY / BLACK	ENGINE COMPARTMENT, BULKHEAD
TRANSMISSION CONTROL MODULE	GB2	16-WAY / BLACK	TRANSMISSION CONTROL VALVE ASSEMBLY

HARNESS IN-LINE CONNECTORS

Connector	Connector Description / Location	Location
FC26	16-WAY / BLUE / CABIN HARNESS TO FASCIA HARNESS	BEHIND INSTRUMENT PANEL, DRIVER SIDE
FH1	20-WAY / BLACK / CABIN HARNESS TO FRONT HARNESS	RH 'A' POST, LOWER
FH3	16-WAY / BLUE / CABIN HARNESS TO FRONT HARNESS	LH 'A' POST
GB1	16-WAY / GREY / ENGINE HARNESS TO TRANSMISSION HARNESS	ADJACENT TO TRANSMISSION BELL HOUSING
PI41	42-WAY / BLACK / ENGINE HARNESS TO VEHICLE HARNESSES	ENGINE COMPARTMENT, BULKHEAD, PASSENGER SIDE
PI42	8-WAY / BLACK / ENGINE HARNESS TO FRONT HARNESS	ENGINE COMPARTMENT, BULKHEAD, PASSENGER SIDE

GROUNDS

Ground	Location
CA141	UNDER LH FRONT SEAT
PI40 (LHD)	ENGINE COMPARTMENT, BEHIND RH WHEEL ARCH LINER
PI40 (RHD)	ENGINE COMPARTMENT, BEHIND LH WHEEL ARCH LINER

FOR CONTROL MODULE PIN-OUT INFORMATION, UNFOLD PAGE TO LEFT.

The following abbreviations are used to represent values for Control Module Pin-Out data

I	Input	PG	Power Ground	C	CAN Network	D	Serial and Encoded Data
O	Output	SS	Sensor / Signal Supply V	S	SCP Network	V	Voltage (DC)
B+	Battery Voltage	SG	Sensor / Signal Ground	D2	D2B Network	PWM	Pulse Width Modulated

CAUTION: The information on this data page is furnished to aid the user in understanding circuit operation. THIS INFORMATION SHOULD BE USED FOR REFERENCE ONLY.

NOTE: The values listed are approximately those that can be expected at the control module connector pins with all circuit connections made and all components connected and fitted.

Refer to the front of this book for detailed information and illustrations regarding the location and identification of harnesses, relays, fuses, grounds, control modules and control module pins.

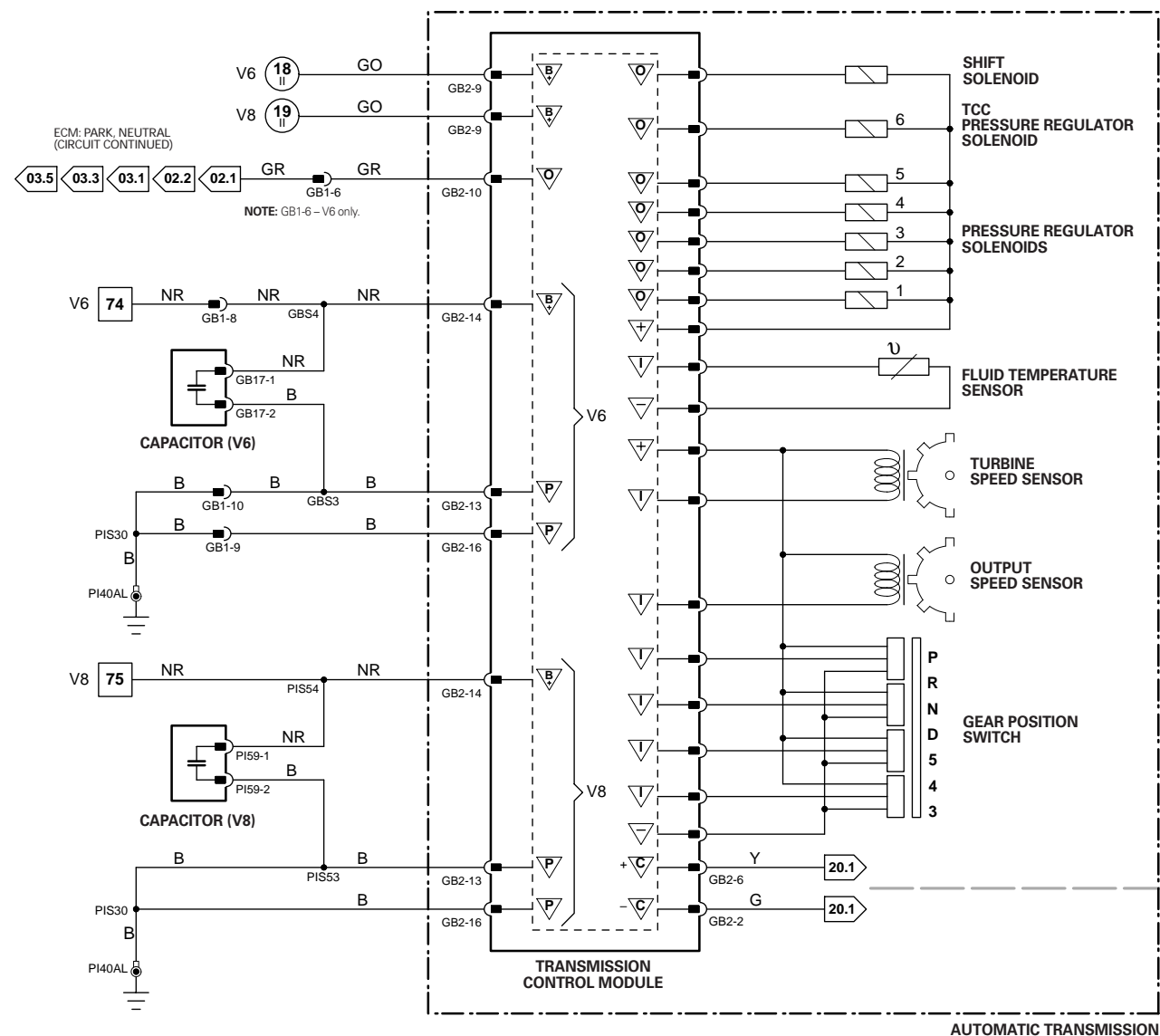

AUTOMATIC TRANSMISSION

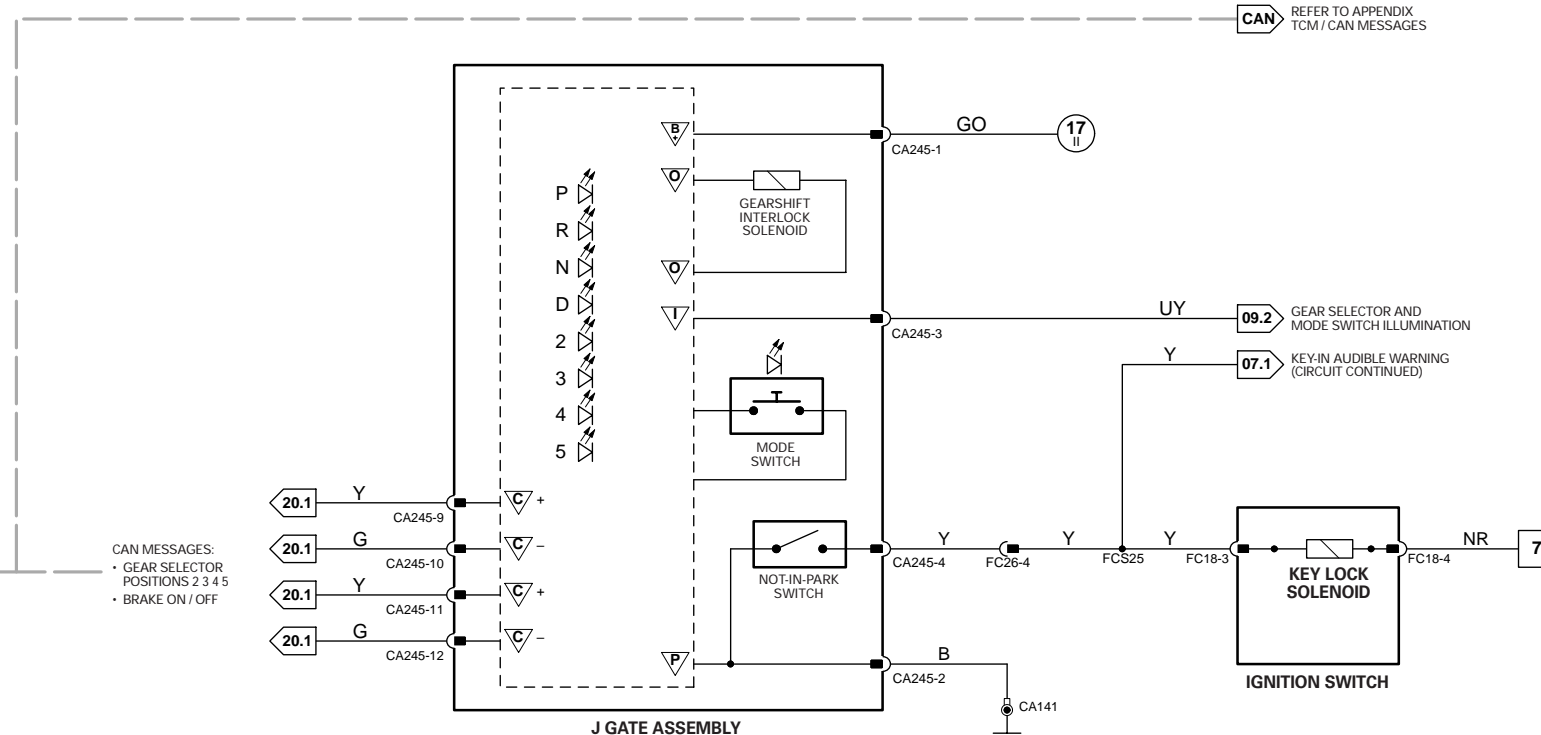

CAN MESSAGES:
 • GEAR SELECTOR POSITIONS 2 3 4 5
 • BRAKE ON / OFF

CAN REFER TO APPENDIX TCM / CAN MESSAGES

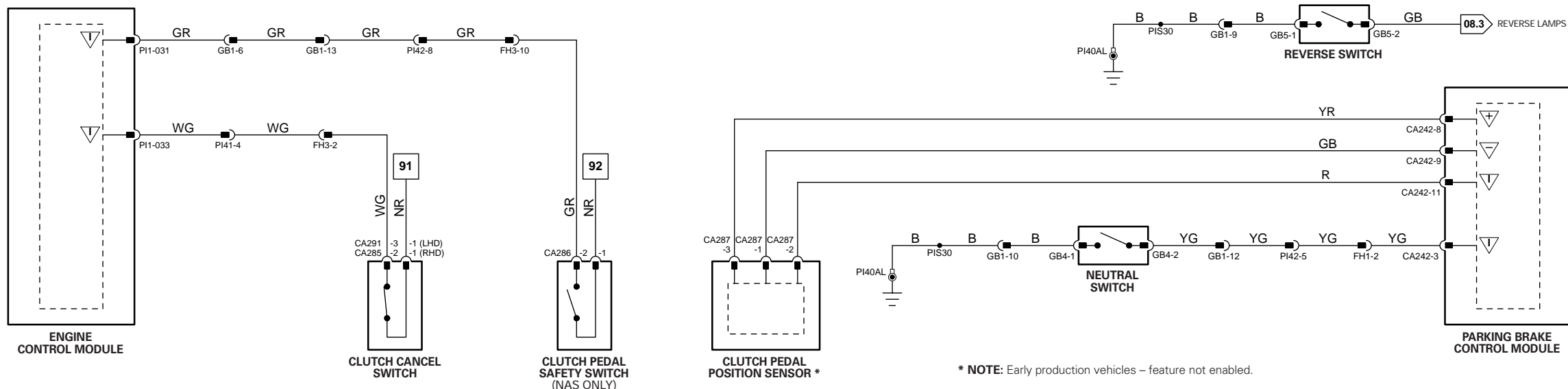

MANUAL TRANSMISSION

* NOTE: Early production vehicles - feature not enabled.

CONTROL MODULE PIN-OUT INFORMATION

Dynamic Stability Control Control Module

Pin	Description and Characteristic
B+	FH103-1 BATTERY POWER SUPPLY - PUMP: B+
-	FH103-3 STEERING ANGLE SENSOR SIGNAL (A): PULSED SIGNAL
B+	FH103-4 IGNITION SWITCHED POWER SUPPLY (I): B+
SG	FH103-5 SENSOR GROUND - YAW RATE, STEERING ANGLE SENSORS: GROUND
I	FH103-6 STEERING ANGLE SENSOR SIGNAL (B): PULSED SIGNAL
SS	FH103-7 YAW RATE, STEERING ANGLE SENSORS SUPPLY VOLTAGE: B+
SG	FH103-8 BRAKE FLUID LEVEL SENSOR SIGNAL GROUND: GROUND
I	FH103-9 BRAKE FLUID LEVEL SENSOR SIGNAL: BRAKE FLUID LEVEL LOW = GROUND
C	FH103-11 CAN +
C	FH103-12 CAN -
O	FH103-13 VEHICLE SPEED SIGNAL (SLIDING ROOF THRESHOLD): < 62 KM/H (38.5 MPH) = GROUND; > 62 KM/H (38.5 MPH) = B+
C	FH103-14 CAN -
C	FH103-15 CAN -
PG	FH103-16 POWER GROUND - VALVES: GROUND
SS	FH103-17 ACTIVE BRAKE BOOSTER SOLENOID SUPPLY VOLTAGE: NOMINAL 5 V
SS	FH103-18 BRAKE PRESSURE SENSOR SUPPLY VOLTAGE: NOMINAL 5 V
SG	FH103-19 SENSOR GROUND - BRAKE PRESSURE SENSOR: GROUND
I	FH103-20 BRAKE PRESSURE SENSOR SIGNAL, NOMINAL 0.5 - 4.5 V: VOLTAGE INCREASES AS PRESSURE INCREASES
SG	FH103-24 ACTIVE BRAKE BOOSTER TRAVEL SENSOR SIGNAL GROUND: GROUND
C	FH103-25 CAN - (LOCAL)
SS	FH103-26 ACTIVE BRAKE BOOSTER TRAVEL SENSOR SUPPLY VOLTAGE: NOMINAL 5 V
SS	FH103-27 ACTIVE BRAKE BOOSTER FORCE SWITCH NORMALLY OPEN (NOMINAL 5 V): OPEN / CLOSED CIRCUIT
I	FH103-28 ACTIVE BRAKE BOOSTER FORCE SWITCH SIGNAL: GROUND
C	FH103-29 CAN + (LOCAL)
SS	FH103-30 ACTIVE BRAKE BOOSTER FORCE SWITCH NORMALLY CLOSED (NOMINAL 5 V): CLOSED / OPEN CIRCUIT
O	FH103-31 ACTIVE BRAKE BOOSTER SOLENOID DRIVE: GROUND (PWM)
B+	FH103-32 BATTERY POWER SUPPLY - VALVES: B+
SG	FH103-33 RH FRONT WHEEL SPEED SENSOR SIGNAL GROUND: GROUND
I	FH103-34 RH FRONT WHEEL SPEED SENSOR SIGNAL: 46 PULSES PER WHEEL REVOLUTION
I	FH103-36 LH REAR WHEEL SPEED SENSOR SIGNAL: 46 PULSES PER WHEEL REVOLUTION
SG	FH103-37 LH REAR WHEEL SPEED SENSOR SIGNAL GROUND: GROUND
I	FH103-38 DYNAMIC STABILITY CONTROL SWITCH: NORMALLY OPEN / GROUND WHEN ACTIVATED
I	FH103-40 ACTIVE BRAKE BOOSTER TRAVEL SENSOR SIGNAL, NOMINAL 0.5 - 4.5 V: VARIABLE VOLTAGE
SG	FH103-42 RH REAR WHEEL SPEED SENSOR SIGNAL GROUND: GROUND
I	FH103-43 RH REAR WHEEL SPEED SENSOR SIGNAL: 46 PULSES PER WHEEL REVOLUTION
I	FH103-45 LH FRONT WHEEL SPEED SENSOR SIGNAL: 46 PULSES PER WHEEL REVOLUTION
SG	FH103-46 LH FRONT WHEEL SPEED SENSOR SIGNAL GROUND: GROUND
PG	FH103-47 POWER GROUND - PUMP: GROUND

NOTE: Refer to the Appendix at the rear of this book for Network Messages.

The following abbreviations are used to represent values for Control Module Pin-Out data

I	Input	PG	Power Ground	C	CAN Network	D	Serial and Encoded Data
O	Output	SS	Sensor / Signal Supply V	S	SCP Network	V	Voltage (DC)
B+	Battery Voltage	SG	Sensor / Signal Ground	D2	D2B Network	PWM	Pulse Width Modulated

CAUTION: The information on this data page is furnished to aid the user in understanding circuit operation. THIS INFORMATION SHOULD BE USED FOR REFERENCE ONLY.

NOTE: The values listed are approximately those that can be expected at the control module connector pins with all circuit connections made and all components connected and fitted.

Fig. 05.1

COMPONENTS

Component	Connector(s)	Connector Description	Location
ACTIVE BRAKE BOOSTER	—	—	ENGINE COMPARTMENT BULKHEAD, DRIVER SIDE
ACTIVE BRAKE BOOSTER SOLENOID	FH56	6-WAY / BLACK	ENGINE COMPARTMENT, BRAKE BOOSTER
BRAKE FLUID RESERVOIR	FH104	2-WAY / BLACK	BRAKE BOOSTER
BRAKE PRESSURE SENSOR	FH54	3-WAY / BLACK	BRAKE MASTER CYLINDER, UNDERSIDE
CENTER CONSOLE SWITCH PACK	FC113 FC119	8-WAY / BLACK 8-WAY / BLACK	CENTER CONSOLE
DYNAMIC STABILITY CONTROL CONTROL MODULE	FH103	47-WAY / BLACK	ENGINE COMPARTMENT, RH FRONT
PEDAL FORCE SWITCH	FH56	6-WAY / BLACK	ENGINE COMPARTMENT, BRAKE BOOSTER
PEDAL TRAVEL SENSOR	FH11	3-WAY / BLACK	ENGINE COMPARTMENT, BRAKE BOOSTER
STEERING ANGLE SENSOR	FC110	4-WAY / GREY	STEERING COLUMN
WHEEL SPEED SENSOR - LH FRONT	FH115	2-WAY / BLACK	LH FRONT WHEEL HUB
WHEEL SPEED SENSOR - LH REAR	RL1	2-WAY / BLACK	LH REAR WHEEL HUB
WHEEL SPEED SENSOR - RH FRONT	FH116	2-WAY / BLACK	RH FRONT WHEEL HUB
WHEEL SPEED SENSOR - RH REAR	RR1	2-WAY / BLACK	RH REAR WHEEL HUB
YAW RATE AND LATERAL ACCELERATION SENSORS CLUSTER	CA236	6-WAY / BLACK	UNDER CENTER CONSOLE

HARNES IN-LINE CONNECTORS

Connector	Connector Description / Location	Location
FC10	14-WAY / GREEN / FASCIA HARNESS TO FRONT HARNESS	BEHIND INSTRUMENT PANEL, RH SIDE
FC26	16-WAY / BLUE / CABIN HARNESS TO FASCIA HARNESS	BEHIND INSTRUMENT PANEL, DRIVER SIDE
FH1	20-WAY / BLACK / CABIN HARNESS TO FRONT HARNESS	RH 'A' POST, LOWER
FH2	16-WAY / GREY / CABIN HARNESS TO FRONT HARNESS	RH 'A' POST, LOWER
FH6	16-WAY GREEN / CABIN HARNESS TO FRONT HARNESS	LH 'A' POST, ADJACENT TO GECM
RL2	2-WAY / BLACK / LH REAR LINK	REAR SUSPENSION SUBFRAME RH SIDE
RR2	2-WAY / BLACK / RH REAR LINK	REAR SUSPENSION SUBFRAME RH SIDE

GROUND

Ground	Location
FC38	UNDER CENTER OF INSTRUMENT PANEL, ON TRANSMISSION TUNNEL
FH42	ENGINE COMPARTMENT, BEHIND RH HEADLAMP

FOR CONTROL MODULE PIN-OUT INFORMATION, UNFOLD PAGE TO LEFT.

Refer to the front of this book for detailed information and illustrations regarding the location and identification of harnesses, relays, fuses, grounds, control modules and control module pins.

CONTROL MODULE PIN-OUT INFORMATION

Parking Brake Control Module

Pin	Description and Characteristic
B+	CA241-1 BATTERY POWER SUPPLY: B+
O	CA241-2 PARKING BRAKE MOTOR ENGAGE: ACTIVATE = B+
O	CA241-3 PARKING BRAKE MOTOR DISENGAGE: ACTIVATE = B+
PG	CA241-4 POWER GROUND: GROUND
S	CA242-1 SCP +
I	CA242-3 IN-GEAR SWITCH (NORMALLY OPEN): OPEN CIRCUIT / GROUND
I	CA242-4 PARKING BRAKE MOTOR POSITION SENSOR FEEDBACK SIGNAL: VARIABLE VOLTAGE
I	CA242-5 PARKING BRAKE SWITCH – APPLY: CHANGE IN RESISTANCE
I	CA242-6 PARKING BRAKE SWITCH – RELEASE: CHANGE IN RESISTANCE
S	CA242-7 SCP -
SS	CA242-8 SIGNAL SUPPLY VOLTAGE: NOMINAL 5 V
SG	CA242-9 SIGNAL GROUND: GROUND
SS	CA242-10 SIGNAL SUPPLY VOLTAGE: NOMINAL 5 V
I	CA242-11 CLUTCH PEDAL POSITION SENSOR FEEDBACK SIGNAL: VARIABLE VOLTAGE
SG	CA242-12 SIGNAL GROUND: GROUND

General Electronic Control Module

Pin	Description and Characteristic
S	FH59-1 SCP -
S	FH59-7 SCP +
PG	FH59-12 POWER GROUND: GROUND
B+	FH60-1 SWITCHED SYSTEM POWER SUPPLY: B+
I	FH60-2 VARIABLE ASSIST STEERING ACTUATOR RETURN: VARIABLE VOLTAGE
O	FH60-9 VARIABLE ASSIST STEERING ACTUATOR DRIVE: B+ (PWM)
PG	FH60-11 POWER GROUND: GROUND
PG	FH60-13 POWER GROUND: GROUND
PG	FH60-14 POWER GROUND: GROUND
PG	FH60-15 POWER GROUND: GROUND

NOTE: Refer to the Appendix at the rear of this book for Network Messages.

Fig. 05.2

COMPONENTS

Component	Connector(s)	Connector Description	Location
CLUTCH PEDAL POSITION SENSOR	CA287	6-WAY / BLACK	TOP OF CLUTCH PEDAL
ELECTRONIC PARKING BRAKE SWITCH	CA243	8-WAY / BLACK	CENTER CONSOLE
GENERAL ELECTRONIC CONTROL MODULE	FH9 CA24 CA31 FH59 FH60	22-WAY / BLACK 26-WAY / NATURAL 20-WAY / BLACK 12-WAY / BLACK 17-WAY / BLACK	LH 'A' POST
NEUTRAL SWITCH	GB4	2-WAY / BLACK	TRANSMISSION, LH REAR
PARKING BRAKE CONTROL MODULE	CA241 CA242	4-WAY / BLACK 12-WAY / BLACK	LUGGAGE COMPARTMENT, RH REAR
PARKING BRAKE MOTOR	CA269	6-WAY / GREY	REAR SUSPENSION SUBFRAME
VARIABLE ASSIST STEERING ACTUATOR	FH16	2-WAY / BLACK	STEERING RACK PINION HOUSING

HARNESS IN-LINE CONNECTORS

Connector	Connector Description / Location	Location
FH1	20-WAY / BLACK / CABIN HARNESS TO FRONT HARNESS	RH 'A' POST, LOWER
GB1	16-WAY / GREY / ENGINE HARNESS TO TRANSMISSION HARNESS	ADJACENT TO TRANSMISSION BELL HOUSING
PI42	8-WAY / BLACK / ENGINE HARNESS TO FRONT HARNESS	ENGINE COMPARTMENT, BULKHEAD, PASSENGER SIDE

GROUND S

Ground	Location
CA141	UNDER LH FRONT SEAT
CA156	LUGGAGE COMPARTMENT, RH SIDE
FH77	LH LOWER 'A' POST, ADJACENT TO THE GENERAL ELECTRONIC CONTROL MODULE (FORWARD OF CA30)
PI40 (LHD)	ENGINE COMPARTMENT, BEHIND RH WHEEL ARCH LINER
PI40 (RHD)	ENGINE COMPARTMENT, BEHIND LH WHEEL ARCH LINER

FOR CONTROL MODULE PIN-OUT INFORMATION, UNFOLD PAGE TO LEFT.

The following abbreviations are used to represent values for Control Module Pin-Out data

I	Input	PG	Power Ground	C	CAN Network	D	Serial and Encoded Data
O	Output	SS	Sensor / Signal Supply V	S	SCP Network	V	Voltage (DC)
B+	Battery Voltage	SG	Sensor / Signal Ground	D2	D2B Network	PWM	Pulse Width Modulated

CAUTION: The information on this data page is furnished to aid the user in understanding circuit operation. THIS INFORMATION SHOULD BE USED FOR REFERENCE ONLY.

NOTE: The values listed are approximately those that can be expected at the control module connector pins with all circuit connections made and all components connected and fitted.

Refer to the front of this book for detailed information and illustrations regarding the location and identification of harnesses, relays, fuses, grounds, control modules and control module pins.

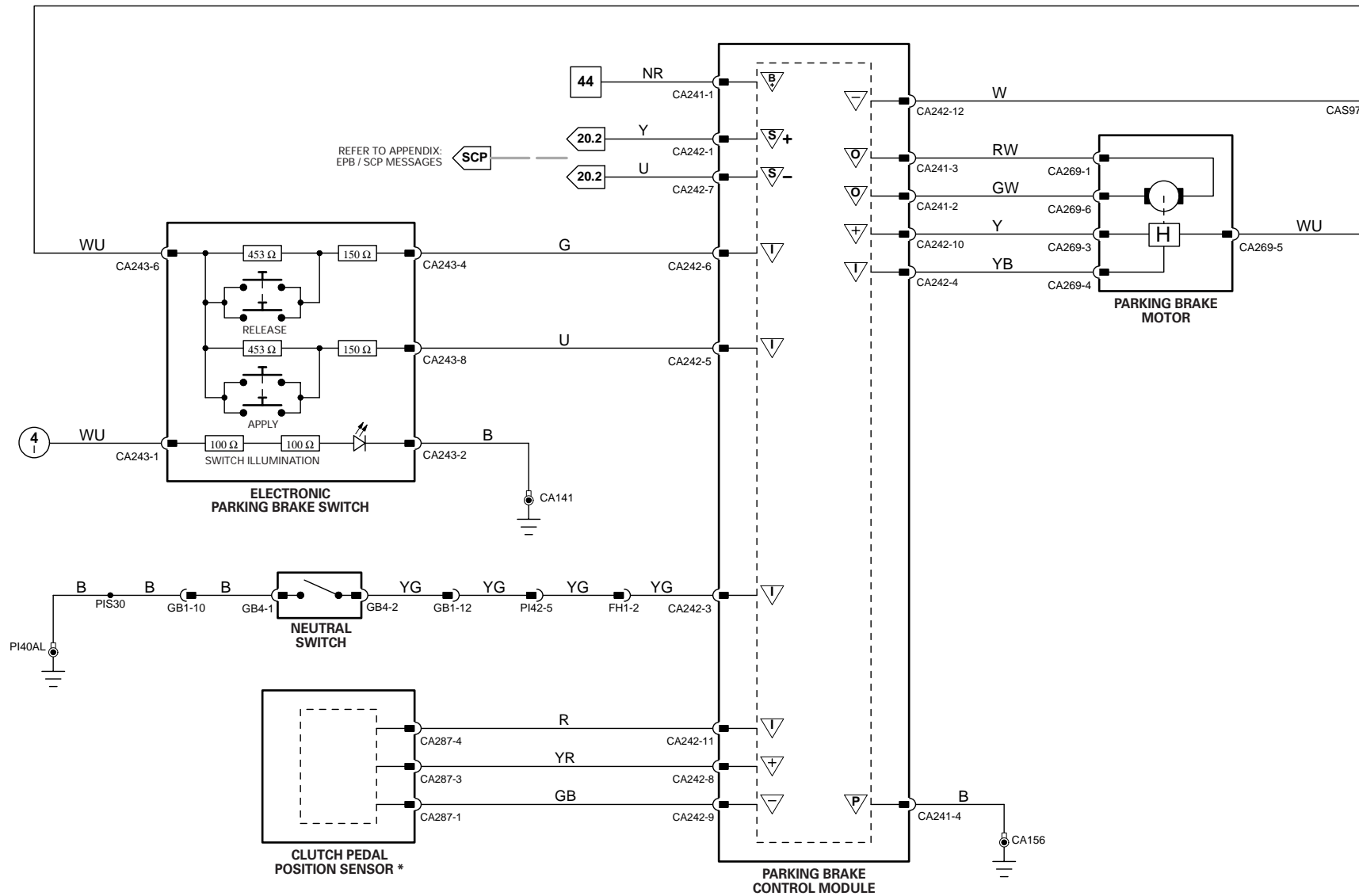

ELECTRONIC PARKING BRAKE

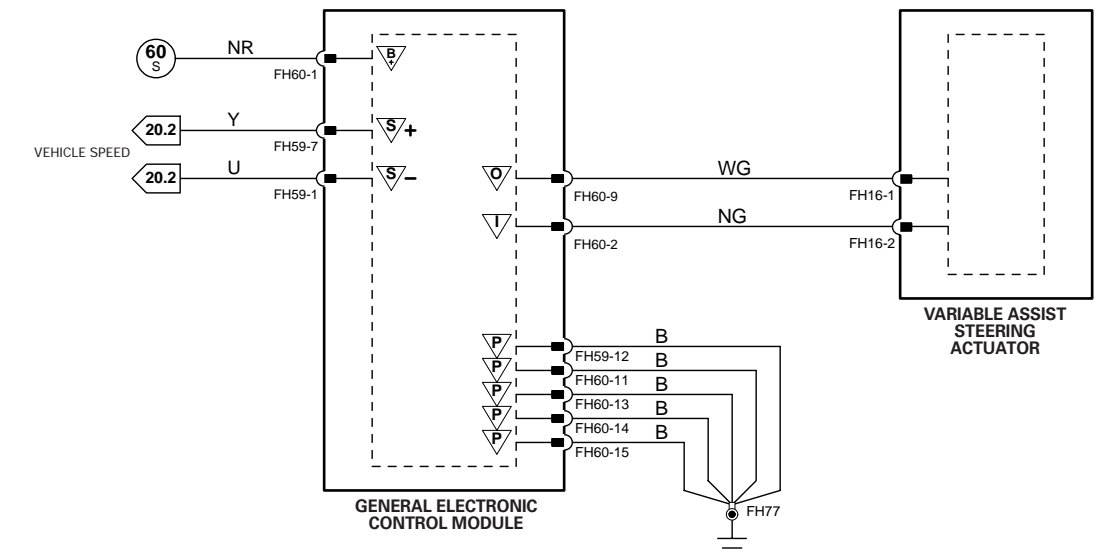

VARIABLE ASSIST POWER STEERING

CONTROL MODULE PIN-OUT INFORMATION

Adaptive Speed Control Control Module

Pin	Description and Characteristic
B+	FH107-1 SWITCHED SYSTEM POWER SUPPLY: B+
PG	FH107-2 POWER GROUND: GROUND
C	FH107-4 CAN -
O	FH107-6 CHIME MODULE DRIVE: CHIME ACTIVATE
B+	FH107-7 IGNITION SWITCHED POWER SUPPLY: B+
C	FH107-10 CAN +
I/O	FH107-12 FORWARD ALERT SWITCH / INDICATOR DRIVE: MONITOR FORWARD ALERT SWITCH / FORWARD ALERT INDICATOR DRIVE

Dynamic Stability Control Control Module

Pin	Description and Characteristic
C	FH103-11 CAN +
C	FH103-12 CAN +
C	FH103-14 CAN -
C	FH103-15 CAN -

Engine Control Module

Pin	Description and Characteristic
SS	PI1-47 SPEED CONTROL SWITCH REQUEST: STEPPED RESISTANCE
I	PI1-48 SPEED CONTROL SWITCHES SIGNAL GROUND: GROUND
C	PI1-123 CAN -
C	PI1-124 CAN +

Instrument Cluster

Pin	Description and Characteristic
C	FC15-8 CAN +
C	FC15-9 CAN -
C	FC15-18 CAN +
C	FC15-19 CAN -

NOTE: Refer to the Appendix at the rear of this book for Network Messages.

Fig. 05.3

COMPONENTS

Component	Connector(s)	Connector Description	Location
ADAPTIVE SPEED CONTROL CHIME MODULE	FC120	4-WAY / BLACK	LH 'A' POST
ADAPTIVE SPEED CONTROL CONTROL MODULE	FH107	12-WAY / BLACK	BELOW LH FRONT BUMPER
DYNAMIC STABILITY CONTROL CONTROL MODULE	FH103	47-WAY / BLACK	ENGINE COMPARTMENT, RH FRONT
ENGINE CONTROL MODULE	PI1	134-WAY / BLACK	FRONT BULKHEAD, PASSENGER SIDE
FUEL / TRUNK RELEASE SWITCH PACK	FC43	10-WAY / GREY	INSTRUMENT PANEL
INSTRUMENT CLUSTER	FC14 FC15 FC63	22-WAY / GREY 20-WAY / BLACK 22-WAY / BLACK	INSTRUMENT PANEL
STEERING WHEEL	—	—	STEERING WHEEL
TRANSMISSION CONTROL MODULE	GB2	16-WAY / BLACK	TRANSMISSION CONTROL VALVE ASSEMBLY

HARNESS IN-LINE CONNECTORS

Connector	Connector Description / Location	Location
FC4	14-WAY / GREEN / FASCIA HARNESS IN-LINE CONNECTOR	BEHIND INSTRUMENT PANEL, LH SIDE
FC10	14-WAY / GREEN / FASCIA HARNESS TO FRONT HARNESS	BEHIND INSTRUMENT PANEL, RH SIDE
FC117	10-WAY / BLACK / STEERING WHEEL CASSETTE	STEERING COLUMN
PI41	42-WAY / BLACK / ENGINE HARNESS TO VEHICLE HARNESSES	ENGINE COMPARTMENT, BULKHEAD, PASSENGER SIDE

GROUNDINGS

Ground	Location
FC38	UNDER CENTER OF INSTRUMENT PANEL, ON TRANSMISSION TUNNEL
FH42	ENGINE COMPARTMENT, BEHIND RH HEADLAMP

FOR CONTROL MODULE PIN-OUT INFORMATION, UNFOLD PAGE TO LEFT.

The following abbreviations are used to represent values for Control Module Pin-Out data

I	Input	PG	Power Ground	C	CAN Network	D	Serial and Encoded Data
O	Output	SS	Sensor / Signal Supply V	S	SCP Network	V	Voltage (DC)
B+	Battery Voltage	SG	Sensor / Signal Ground	D2	D2B Network	PWM	Pulse Width Modulated

CAUTION: The information on this data page is furnished to aid the user in understanding circuit operation. THIS INFORMATION SHOULD BE USED FOR REFERENCE ONLY.

NOTE: The values listed are approximately those that can be expected at the control module connector pins with all circuit connections made and all components connected and fitted.

Refer to the front of this book for detailed information and illustrations regarding the location and identification of harnesses, relays, fuses, grounds, control modules and control module pins.

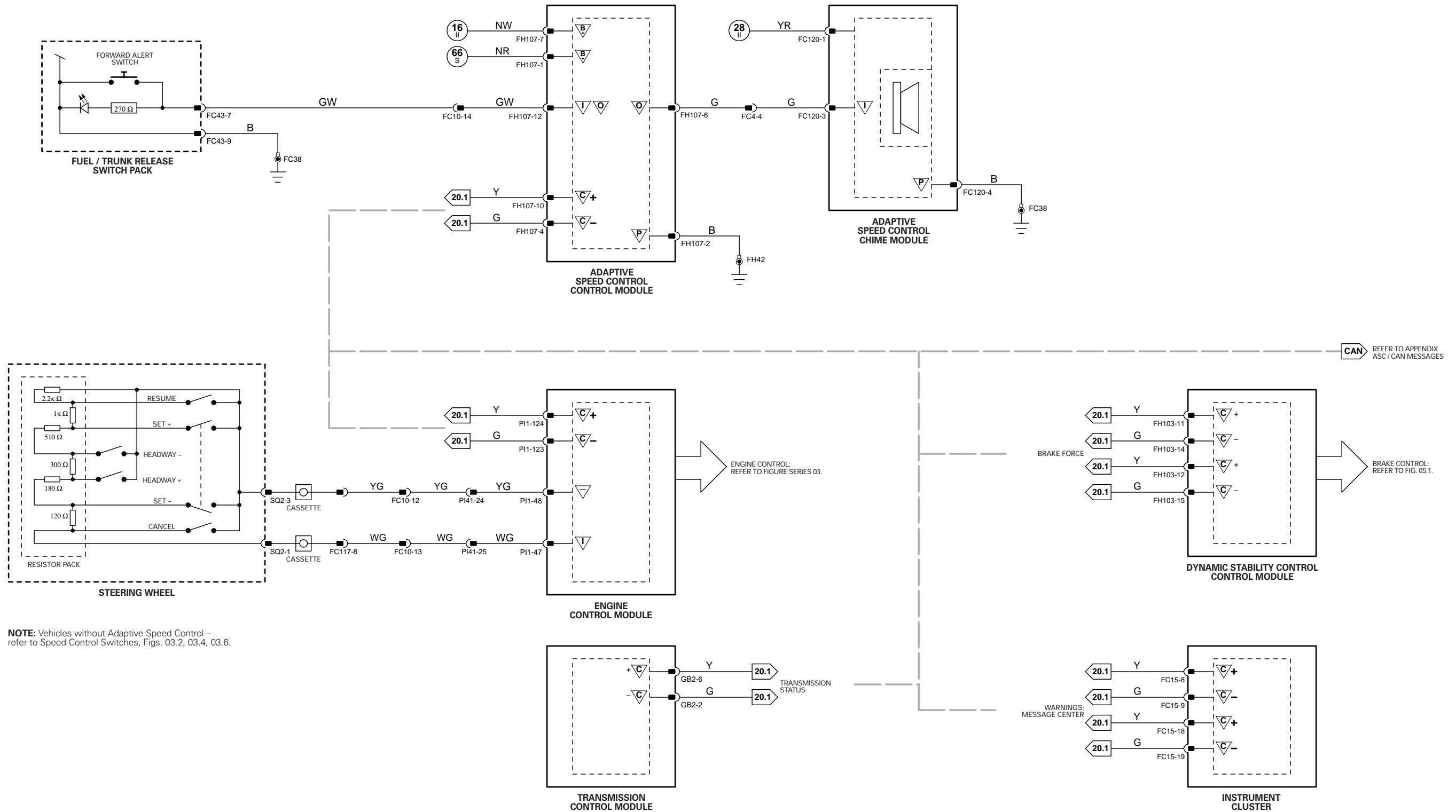

NOTE: Vehicles without Adaptive Speed Control – refer to Speed Control Switches, Figs. 03.2, 03.4, 03.6.

NOTE: Early production vehicles – Adaptive Speed Control not fitted.

CONTROL MODULE PIN-OUT INFORMATION

Adaptive Damping Control Module

Pin	Description and Characteristic
O CA11-1	RH REAR DAMPER SOLENOID DRIVE: PWM +
O CA11-2	RH REAR DAMPER SOLENOID DRIVE: PWM -
O CA11-3	LH REAR DAMPER SOLENOID DRIVE: PWM +
O CA11-4	LH REAR DAMPER SOLENOID DRIVE: PWM -
O CA11-5	LH FRONT DAMPER SOLENOID DRIVE: PWM -
O CA11-6	LH FRONT DAMPER SOLENOID DRIVE: PWM +
O CA11-7	RH FRONT DAMPER SOLENOID DRIVE: PWM -
O CA11-8	RH FRONT DAMPER SOLENOID DRIVE: PWM +
SG CA11-9	SIGNAL GROUND (INTERNALLY CONNECTED TO PIN 10): GROUND
PG CA11-10	POWER GROUND: GROUND
B+ CA11-12	IGNITION SWITCHED POWER SUPPLY (I): B+
S CA11-13	SCP -
S CA11-14	SCP +
B+ CA11-16	BATTERY POWER SUPPLY: B+
SS CA12-9	SENSOR SIGNAL SUPPLY VOLTAGE: NOMINAL 5 V
I CA12-10	REAR VERTICAL ACCELEROMETER SIGNAL: SENSOR SIGNAL
I CA12-11	LATERAL ACCELEROMETER SIGNAL: SENSOR SIGNAL
I CA12-12	FRONT VERTICAL ACCELEROMETER SIGNAL: SENSOR SIGNAL

Dynamic Stability Control Control Module

Pin	Description and Characteristic
C FH103-11	CAN +
C FH103-12	CAN +
C FH103-14	CAN -
C FH103-15	CAN -

Instrument Cluster

Pin	Description and Characteristic
C FC15-8	CAN +
C FC15-9	CAN -
S FC15-10	SCP -
C FC15-18	CAN +
C FC15-19	CAN -
S FC15-20	SCP +

Rear Electronic Control Module

Pin	Description and Characteristic
S CA102-1	SCP +
S CA102-2	SCP -

NOTE: Refer to the Appendix at the rear of this book for Network Messages.

The following abbreviations are used to represent values for Control Module Pin-Out data

I	Input	PG	Power Ground	C	CAN Network	D	Serial and Encoded Data
O	Output	SS	Sensor / Signal Supply V	S	SCP Network	V	Voltage (DC)
B+	Battery Voltage	SG	Sensor / Signal Ground	D2	D2B Network	PWM	Pulse Width Modulated

CAUTION: The information on this data page is furnished to aid the user in understanding circuit operation. THIS INFORMATION SHOULD BE USED FOR REFERENCE ONLY.

NOTE: The values listed are approximately those that can be expected at the control module connector pins with all circuit connections made and all components connected and fitted.

Fig. 05.4

COMPONENTS

Component	Connector(s)	Connector Description	Location
ADAPTIVE DAMPING CONTROL MODULE	CA11 CA12	16-WAY / BLUE 16-WAY / GREY	LUGGAGE COMPARTMENT, REAR
DAMPER SOLENOID - LH FRONT	FH117	2-WAY BLACK	TOP OF LH FRONT DAMPER
DAMPER SOLENOID - LH REAR	CA140	2-WAY BLACK	TOP OF LH REAR DAMPER
DAMPER SOLENOID - RH FRONT	FH118	2-WAY BLACK	TOP OF RH FRONT DAMPER
DAMPER SOLENOID - RH REAR	CA111	2-WAY BLACK	TOP OF RH REAR DAMPER
DYNAMIC STABILITY CONTROL CONTROL MODULE	FH103	47-WAY / BLACK	ENGINE COMPARTMENT, RH FRONT
INSTRUMENT CLUSTER	FC14 FC15 FC63	22-WAY / GREY 20-WAY / BLACK 22-WAY / BLACK	INSTRUMENT PANEL
LATERAL ACCELEROMETER	FH70	3-WAY / BLACK	REARWARD OF FRONT BUMPER, LH SIDE
REAR ELECTRONIC CONTROL MODULE	CA63 CA100 CA101 CA102 CA103	17-WAY / BLACK 12-WAY / BLACK 20-WAY / BLACK 22-WAY / BLACK 26-WAY / NATURAL	LUGGAGE COMPARTMENT, RH REAR
VERTICAL ACCELEROMETER - FRONT	FH63	3-WAY / BLACK	REARWARD OF FRONT BUMPER, LH SIDE
VERTICAL ACCELEROMETER - REAR	CA17	3-WAY / BLACK	LUGGAGE COMPARTMENT, RH REAR

HARNESS IN-LINE CONNECTORS

Connector	Connector Description / Location	Location
CA3A/B	14-WAY / GREY / CABIN HARNESS BRIDGE	LUGGAGE COMPARTMENT, LH REAR
CA4A/B	10-WAY / GREY / CABIN HARNESS BRIDGE	LUGGAGE COMPARTMENT, LH REAR
FH2	16-WAY / GREY / CABIN HARNESS TO FRONT HARNESS	RH 'A' POST, LOWER
FH6	16-WAY GREEN / CABIN HARNESS TO FRONT HARNESS	LH 'A' POST, ADJACENT TO GECM

GROUND

Ground	Location
CA158	LUGGAGE COMPARTMENT, LH SIDE REAR CORNER

FOR CONTROL MODULE PIN-OUT INFORMATION, UNFOLD PAGE TO LEFT.

Refer to the front of this book for detailed information and illustrations regarding the location and identification of harnesses, relays, fuses, grounds, control modules and control module pins.

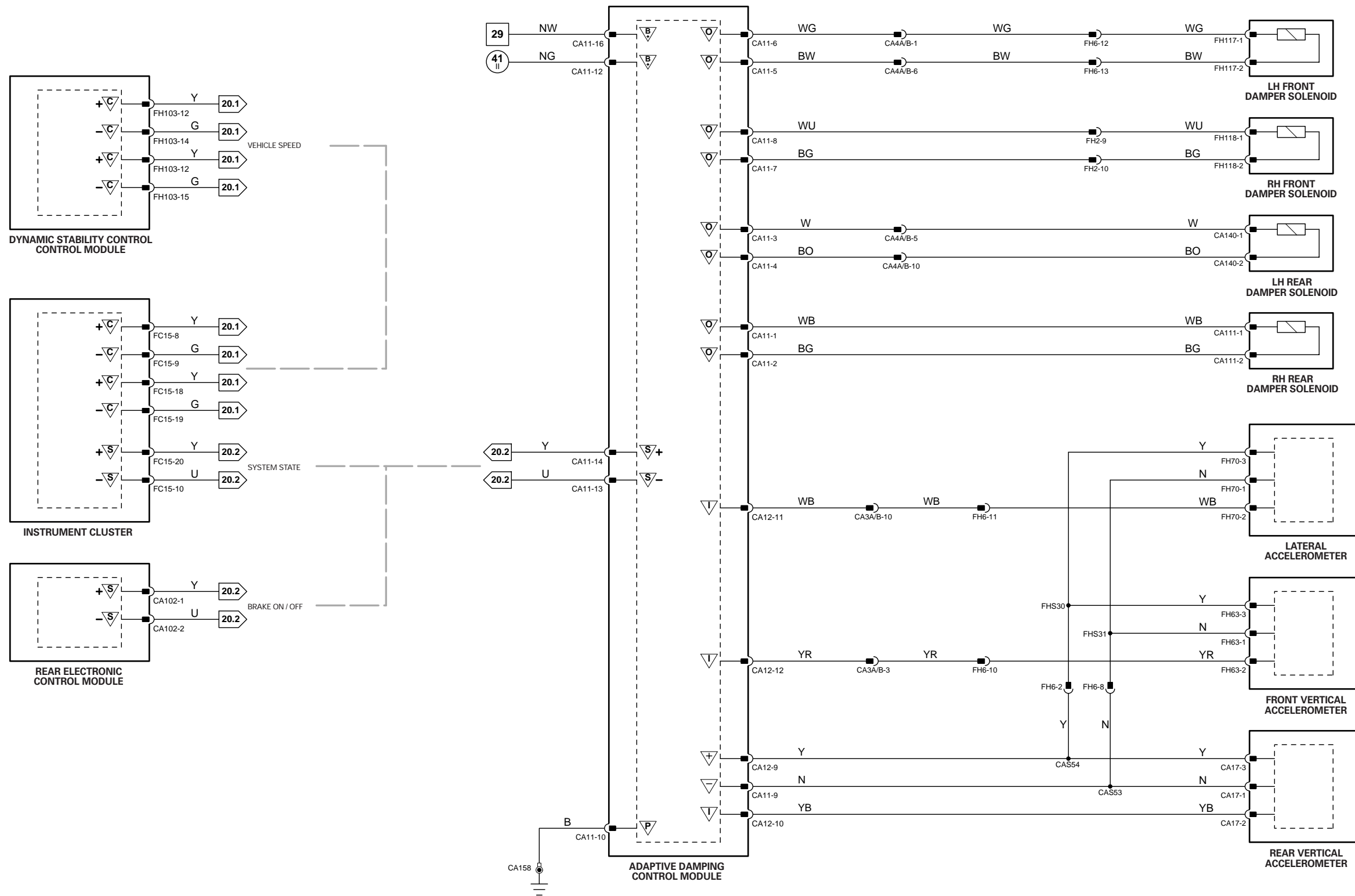

CONTROL MODULE PIN-OUT INFORMATION

Air Conditioning Control Module – Panel

Pin	Description and Characteristic
I	FC27-1 DEFROST MODE ACTUATOR POSITION FEEDBACK: VARIABLE VOLTAGE
I	FC27-2 COLD AIR BYPASS ACTUATOR POSITION FEEDBACK: VARIABLE VOLTAGE
I	FC27-3 PANEL MODE ACTUATOR POSITION FEEDBACK: VARIABLE VOLTAGE
I	FC27-4 HUMIDITY SENSOR SIGNAL: VARIABLE VOLTAGE
O	FC27-5 DRIVER SIDE DUAL COOLANT CONTROL VALVE CONTROL DRIVE: ACTIVATE = GROUND (PWM)
O	FC27-6 PASSENGER SIDE DUAL COOLANT CONTROL VALVE CONTROL DRIVE: ACTIVATE = GROUND (PWM)
SS	FC27-7 HUMIDITY SENSOR SIGNAL SUPPLY VOLTAGE: NOMINAL 5 V
O	FC27-9 FRESH / RECIRCULATION ACTUATOR DRIVE – CLOSE: ACTIVATE = B+
O	FC27-10 FRESH / RECIRCULATION ACTUATOR DRIVE – OPEN: ACTIVATE = B+
O	FC27-11 COLD AIR BYPASS ACTUATOR DRIVE – OPEN: ACTIVATE = B+
O	FC27-12 COLD AIR BYPASS ACTUATOR DRIVE – CLOSE: ACTIVATE = B+
O	FC27-13 DEFROST MODE ACTUATOR DRIVE – OPEN: ACTIVATE = B+
SG	FC27-14 IN-CAR TEMPERATURE SENSOR SIGNAL GROUND: GROUND
I	FC27-15 FRESH / RECIRCULATION ACTUATOR POSITION FEEDBACK: VARIABLE VOLTAGE
I	FC27-16 FLOOR MODE ACTUATOR POSITION FEEDBACK: VARIABLE VOLTAGE
SG	FC27-17 ACTUATOR SIGNAL GROUND: GROUND
O	FC27-18 AUXILIARY COOLANT PUMP RELAY ACTIVATE: TO ACTIVATE, A/CCM SWITCHES CIRCUIT TO GROUND
O	FC27-19 BLOWER MOTOR RELAY ACTIVATE: TO ACTIVATE, A/CCM SWITCHES CIRCUIT TO GROUND
O	FC27-20 HEATED WIPER PARK OR HEATED WINDSHIELD RELAY(S) ACTIVATE: TO ACTIVATE, A/CCM SWITCHES CIRCUIT TO GROUND
O	FC27-21 BLOWER MOTOR CONTROL: B+ (PWM)
O	FC27-22 FLOOR MODE ACTUATOR DRIVE – OPEN: ACTIVATE = B+
O	FC27-23 FLOOR MODE ACTUATOR DRIVE – CLOSE: ACTIVATE = B+
O	FC27-24 PANEL MODE ACTUATOR DRIVE – OPEN: ACTIVATE = B+
O	FC27-25 PANEL MODE ACTUATOR DRIVE – CLOSE: ACTIVATE = B+
O	FC27-26 DEFROST MODE ACTUATOR DRIVE – CLOSE: ACTIVATE = B+
C	FC28-1 CAN -
PG	FC28-2 POWER GROUND: GROUND
B+	FC28-3 IGNITION SWITCHED POWER SUPPLY (I): B+
I	FC28-5 BLOWER MOTOR CONTROL FEEDBACK: VARIABLE FREQUENCY
I	FC28-6 PASSENGER SIDE DISCHARGE TEMPERATURE SENSOR SIGNAL: NTC SENSOR / VOLTAGE DECREASES AS TEMPERATURE INCREASES
I	FC28-7 DUAL SOLAR SENSOR SIGNAL – LH: VOLTAGE DECREASES AS LIGHT INCREASES
SG	FC28-8 AMBIENT TEMPERATURE SENSOR SIGNAL GROUND: GROUND
I	FC28-9 IN-CAR TEMPERATURE SENSOR SIGNAL: NTC SENSOR / VOLTAGE DECREASES AS TEMPERATURE INCREASES
I	FC28-10 EVAPORATOR DISCHARGE TEMPERATURE SENSOR SIGNAL: NTC SENSOR / VOLTAGE DECREASES AS TEMPERATURE INCREASES
SG	FC28-11 ACTUATORS SIGNAL GROUND: GROUND
C	FC28-12 CAN
B+	FC28-14 BATTERY POWER SUPPLY: B+
I	FC28-15 PANEL ILLUMINATION (DIMMER CONTROLLED): B+ (PWM)
SG	FC28-16 EVAPORATOR DISCHARGE TEMPERATURE SENSOR SIGNAL GROUND: GROUND
I	FC28-17 AMBIENT TEMPERATURE SENSOR SIGNAL: NTC SENSOR / VOLTAGE DECREASES AS TEMPERATURE INCREASES
I	FC28-18 DRIVER SIDE DISCHARGE TEMPERATURE SENSOR SIGNAL: NTC SENSOR / VOLTAGE DECREASES AS TEMPERATURE INCREASES
SG	FC28-19 LH / RH DISCHARGE TEMPERATURE SENSORS SIGNAL GROUND: GROUND
I	FC28-20 DUAL SOLAR SENSOR SIGNAL – RH: VOLTAGE DECREASES AS LIGHT INCREASES
SS	FC28-22 ACTUATORS SIGNAL SUPPLY VOLTAGE: NOMINAL 5 V

Air Conditioning Control Module – Remote

Pin	Description and Characteristic
I	FC40-1 DEFROST MODE ACTUATOR POSITION FEEDBACK: VARIABLE VOLTAGE
I	FC40-2 COLD AIR BYPASS ACTUATOR POSITION FEEDBACK: VARIABLE VOLTAGE
I	FC40-3 PANEL MODE ACTUATOR POSITION FEEDBACK: VARIABLE VOLTAGE
I	FC40-4 HUMIDITY SENSOR SIGNAL: VARIABLE VOLTAGE
O	FC40-5 DRIVER SIDE DUAL COOLANT CONTROL VALVE CONTROL DRIVE: ACTIVATE = GROUND (PWM)
O	FC40-6 PASSENGER SIDE DUAL COOLANT CONTROL VALVE CONTROL DRIVE: ACTIVATE = GROUND (PWM)
SS	FC40-7 HUMIDITY SENSOR SIGNAL SUPPLY VOLTAGE: NOMINAL 5 V
O	FC40-9 FRESH / RECIRCULATION ACTUATOR DRIVE – CLOSE: ACTIVATE = B+
O	FC40-10 FRESH / RECIRCULATION ACTUATOR DRIVE – OPEN: ACTIVATE = B+
O	FC40-11 COLD AIR BYPASS ACTUATOR DRIVE – OPEN: ACTIVATE = B+
O	FC40-12 COLD AIR BYPASS ACTUATOR DRIVE – CLOSE: ACTIVATE = B+
O	FC40-13 DEFROST MODE ACTUATOR DRIVE – OPEN: ACTIVATE = B+
SG	FC40-14 IN-CAR TEMPERATURE SENSOR SIGNAL GROUND: GROUND
I	FC40-15 FRESH / RECIRCULATION ACTUATOR POSITION FEEDBACK: VARIABLE VOLTAGE
I	FC40-16 FLOOR MODE ACTUATOR POSITION FEEDBACK: VARIABLE VOLTAGE
SG	FC40-17 ACTUATOR SIGNAL GROUND: GROUND
O	FC40-18 AUXILIARY COOLANT PUMP RELAY ACTIVATE: TO ACTIVATE, A/CCM SWITCHES CIRCUIT TO GROUND
O	FC40-19 BLOWER MOTOR RELAY ACTIVATE: TO ACTIVATE, A/CCM SWITCHES CIRCUIT TO GROUND
O	FC40-20 HEATED WIPER PARK OR HEATED WINDSHIELD RELAY(S) ACTIVATE: TO ACTIVATE, A/CCM SWITCHES CIRCUIT TO GROUND
O	FC40-21 BLOWER MOTOR CONTROL: B+ (PWM)
O	FC40-22 FLOOR MODE ACTUATOR DRIVE – OPEN: ACTIVATE = B+
O	FC40-23 FLOOR MODE ACTUATOR DRIVE – CLOSE: ACTIVATE = B+
O	FC40-24 PANEL MODE ACTUATOR DRIVE – OPEN: ACTIVATE = B+
O	FC40-25 PANEL MODE ACTUATOR DRIVE – CLOSE: ACTIVATE = B+
O	FC40-26 DEFROST MODE ACTUATOR DRIVE – CLOSE: ACTIVATE = B+
C	FC41-1 CAN -
PG	FC41-2 POWER GROUND: GROUND
B+	FC41-3 IGNITION SWITCHED POWER SUPPLY (I): B+
I	FC41-5 BLOWER MOTOR CONTROL FEEDBACK: VARIABLE FREQUENCY
I	FC41-6 PASSENGER SIDE DISCHARGE TEMPERATURE SENSOR SIGNAL: NTC SENSOR / VOLTAGE DECREASES AS TEMPERATURE INCREASES
I	FC41-7 DUAL SOLAR SENSOR SIGNAL – LH: VOLTAGE DECREASES AS LIGHT INCREASES
SG	FC41-8 AMBIENT TEMPERATURE SENSOR SIGNAL GROUND: GROUND
I	FC41-9 IN-CAR TEMPERATURE SENSOR SIGNAL: NTC SENSOR / VOLTAGE DECREASES AS TEMPERATURE INCREASES
I	FC41-10 EVAPORATOR DISCHARGE TEMPERATURE SENSOR SIGNAL: NTC SENSOR / VOLTAGE DECREASES AS TEMPERATURE INCREASES
SG	FC41-11 ACTUATORS SIGNAL GROUND: GROUND
C	FC41-12 CAN +
B+	FC41-14 BATTERY POWER SUPPLY: B+
SG	FC41-16 EVAPORATOR DISCHARGE TEMPERATURE SENSOR SIGNAL GROUND: GROUND
I	FC41-17 AMBIENT TEMPERATURE SENSOR SIGNAL: NTC SENSOR / VOLTAGE DECREASES AS TEMPERATURE INCREASES
I	FC41-18 DRIVER SIDE DISCHARGE TEMPERATURE SENSOR SIGNAL: NTC SENSOR / VOLTAGE DECREASES AS TEMPERATURE INCREASES
SG	FC41-19 LH / RH DISCHARGE TEMPERATURE SENSORS SIGNAL GROUND: GROUND
I	FC41-20 DUAL SOLAR SENSOR SIGNAL – RH: VOLTAGE DECREASES AS LIGHT INCREASES
SS	FC41-22 ACTUATORS SIGNAL SUPPLY VOLTAGE: NOMINAL 5 V

NOTE: Refer to the Appendix at the rear of this book for Network Messages.

The following abbreviations are used to represent values for Control Module Pin-Out data

I	Input	PG	Power Ground	C	CAN Network	D	Serial and Encoded Data
O	Output	SS	Sensor / Signal Supply V	S	SCP Network	V	Voltage (DC)
B+	Battery Voltage	SG	Sensor / Signal Ground	D2	D2B Network	PWM	Pulse Width Modulated

CAUTION: The information on this data page is furnished to aid the user in understanding circuit operation. THIS INFORMATION SHOULD BE USED FOR REFERENCE ONLY.

NOTE: The values listed are approximately those that can be expected at the control module connector pins with all circuit connections made and all components connected and fitted.

Fig. 06.1

COMPONENTS

Component	Connector(s)	Connector Description	Location
AIR CONDITIONING CONTROL MODULE – PANEL	FC27 FC28	26-WAY / GREY 22-WAY / GREY	CENTER CONSOLE
AIR CONDITIONING CONTROL MODULE – REMOTE	FC40 FC41	26-WAY / GREY 22-WAY / GREY	BEHIND INSTRUMENT PANEL, RH SIDE (LHD), LH SIDE (RHD)
AMBIENT TEMPERATURE SENSOR	FH30	2-WAY / BLACK	UNDER FRONT BUMPER, CENTER, FORWARD OF RADIATOR
AUXILIARY COOLANT PUMP	CP4	2-WAY / BLACK	ENGINE COMPARTMENT, BEHIND RADIATOR, LH SIDE
AUXILIARY COOLANT PUMP RELAY	—	—	FRONT POWER DISTRIBUTION FUSE BOX – R7
BLOWER MOTOR	AC2	6-WAY / BLACK	UNDER INSTRUMENT PANEL, RH SIDE (LHD), LH SIDE (RHD)
BLOWER MOTOR RELAY	—	—	REAR POWER DISTRIBUTION FUSE BOX – R7
COLD AIR BYPASS ACTUATOR	AC4	6-WAY / BLACK	AIR DISTRIBUTION BOX
DEFROST MODE ACTUATOR	FC29	6-WAY / BLACK	AIR DISTRIBUTION BOX
DISCHARGE TEMPERATURE SENSOR – EVAPORATOR	AC5	2-WAY / GREY	AIR DISTRIBUTION BOX
DISCHARGE TEMPERATURE SENSOR – LH	FC20	2-WAY BLACK	AIR DISTRIBUTION BOX
DISCHARGE TEMPERATURE SENSOR – RH	FC30	2-WAY BLACK	AIR DISTRIBUTION BOX
DUAL COOLANT CONTROL VALVE	CP5	3-WAY / BLACK	ENGINE COMPARTMENT, RH SIDE, REARWARD OF RADIATOR
DUAL SOLAR SENSOR	SL1	6-WAY / BLACK	INSTRUMENT PANEL GLARE SHIELD, FRONT CENTER
FLOOR MODE ACTUATOR	FC21	6-WAY / BLACK	AIR DISTRIBUTION BOX
FRESH / RECIRCULATION ACTUATOR	AC3	6-WAY / BLACK	BLOWER INTAKE
FRONT POWER DISTRIBUTION FUSE BOX	—	—	ENGINE COMPARTMENT, RH SIDE
HUMIDITY SENSOR	FC24	4-WAY / BLACK	INSTRUMENT PANEL, ADJACENT TO STEERING COLUMN
IN-CAR TEMPERATURE SENSOR	FC24	4-WAY / BLACK	INSTRUMENT PANEL, ADJACENT TO STEERING COLUMN
LH WINDSHIELD HEATER	CA122 CA279	1-WAY / BLACK 1-WAY / BLACK	CONNECTORS LOCATED IN LH UPPER 'A' POST
LH WINDSHIELD HEATER RELAY	—	—	FRONT POWER DISTRIBUTION FUSE BOX – R17
PANEL MODE ACTUATOR	FC22	6-WAY / BLACK	AIR DISTRIBUTION BOX
REAR POWER DISTRIBUTION FUSE BOX	—	—	LUGGAGE COMPARTMENT
WIPER PARK HEATER / RH WINDSHIELD HEATER RELAY	—	—	FRONT POWER DISTRIBUTION FUSE BOX – R21
WIPER PARK HEATER OR RH WINDSHIELD HEATER	CA65 CA71	1-WAY / BLACK 1-WAY / BLACK	CONNECTORS LOCATED IN RH UPPER 'A' POST

HARNESS IN-LINE CONNECTORS

Connector	Connector Description / Location	Location
AC7	2-WAY / GREY / CABIN HARNESS TO CLIMATE CONTROL HARNESS	BEHIND PASSENGER AIRBAG
CP1	10-WAY / BLACK / INTERCOOLER PUMP LINK LEAD	ENGINE COMPARTMENT, RH FRONT, ADJACENT TO RADIATOR
FC4	14-WAY / GREEN / FASCIA HARNESS IN-LINE CONNECTOR	BEHIND INSTRUMENT PANEL, LH SIDE
FC10	14-WAY / GREEN / FASCIA HARNESS TO FRONT HARNESS	BEHIND INSTRUMENT PANEL, RH SIDE
FC33	16-WAY / GREEN / CABIN HARNESS TO FASCIA HARNESS	BEHIND INSTRUMENT PANEL, RH SIDE
FC34	16-WAY / GREEN / FASCIA HARNESS IN-LINE CONNECTOR	ADJACENT TO BLOWER MOTOR
FH82	2-WAY / GREY / CABIN HARNESS TO FRONT HARNESS	RH 'A' POST
FH114	2-WAY / GREY / FRONT HARNESS TO CABIN HARNESS	BEHIND INSTRUMENT PANEL, LH SIDE
SL3	10-WAY / GREY / FASCIA HARNESS TO SOLAR SENSOR LINK	BEHIND INSTRUMENT PANEL, RH SIDE

GROUNDINGS

Ground	Location
CA30	LH LOWER 'A' POST, ADJACENT TO THE GENERAL ELECTRONIC CONTROL MODULE (REARWARD OF FH77)
CA50	RH LOWER 'A' POST, BELOW PRIMARY JUNCTION FUSE BOX
FC38	UNDER CENTER OF INSTRUMENT PANEL, ON TRANSMISSION TUNNEL
FH42	ENGINE COMPARTMENT, BEHIND RH HEADLAMP

FOR CONTROL MODULE PIN-OUT INFORMATION, UNFOLD PAGE TO LEFT.

Refer to the front of this book for detailed information and illustrations regarding the location and identification of harnesses, relays, fuses, grounds, control modules and control module pins.

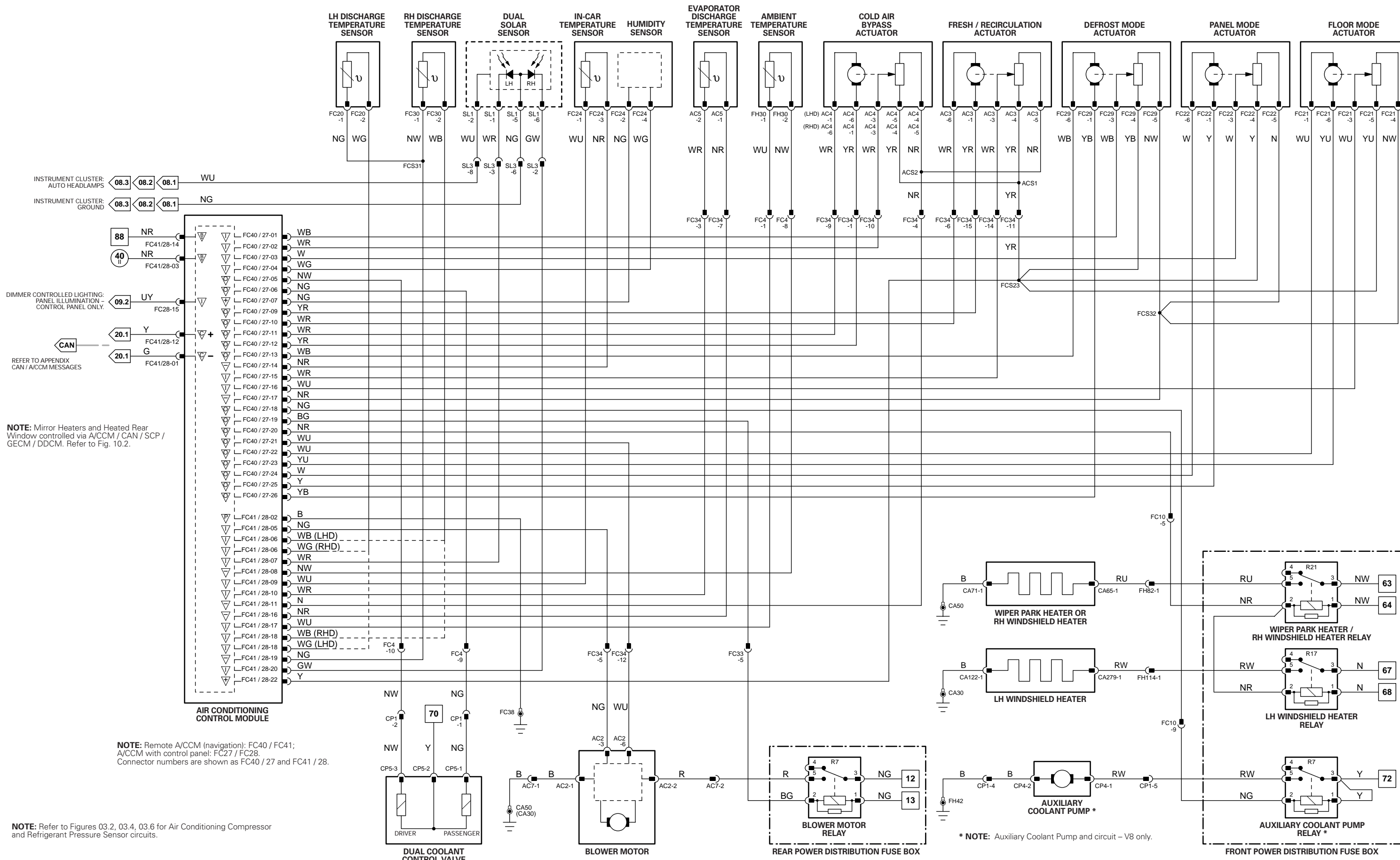

CONTROL MODULE PIN-OUT INFORMATION

General Electronic Control Module

Pin	Description and Characteristic
I FH9-15	WASHER FLUID LEVEL SWITCH (NORMALLY OPEN): OPEN CIRCUIT / GROUND
S FH59-1	SCP -
B+ FH59-6	BATTERY POWER SUPPLY (LOGIC): B+
S FH59-7	SCP +
I FH59-9	ENGINE OIL PRESSURE SWITCH (NORMALLY OPEN): OPEN CIRCUIT / GROUND
PG FH59-12	POWER GROUND: GROUND
PG FH60-11	POWER GROUND: GROUND
PG FH60-13	POWER GROUND: GROUND
PG FH60-14	POWER GROUND: GROUND
PG FH60-15	POWER GROUND: GROUND

Instrument Cluster

Pin	Description and Characteristic
I FC14-1	AIR BAG WARNING: HARD WIRED TO AIR BAG INDICATOR
I FC14-2	KEY-IN AUDIBLE WARNING: B+ WHEN KEY IN
B+ FC14-3	IGNITION SWITCHED POWER SUPPLY (I): B+
B+ FC14-4	IGNITION SWITCHED POWER SUPPLY (I): B+
I FC14-5	LOW ENGINE COOLANT LEVEL WARNING: GROUND WHEN COOLANT LEVEL LOW
I FC14-7	KEY-IN AUDIBLE WARNING (J-GATE): GROUND WHEN NOT-IN-PARK
I FC14-8	SEAT BELT AUDIBLE WARNING REQUEST: AUDIBLE WARNING REQUEST ACTIVE = GROUND
B+ FC14-12	IGNITION SWITCHED POWER SUPPLY (I) (AIRBAG WARNING): B+
SG FC14-14	SIGNAL GROUND: GROUND
PG FC15-2	POWER GROUND: GROUND
B+ FC15-3	BATTERY POWER SUPPLY (LOGIC): B+
C FC15-8	CAN +
C FC15-9	CAN -
S FC15-10	SCP -
C FC15-18	CAN +
C FC15-19	CAN -
S FC15-20	SCP +
SG FC63-3	MAIN LIGHTING SWITCH SIGNAL GROUND: GROUND
I FC63-4	TRIP COMPUTER - MESSAGE CENTER SIGNALS: VARIABLE RESISTANCE
I FC63-14	TRIP CYCLE SWITCH - MESSAGE CENTER SIGNAL: VARIABLE RESISTANCE
SG FC63-15	AUXILIARY LIGHTING SWITCH SIGNAL GROUND: GROUND

Rear Electronic Control Module

Pin	Description and Characteristic
B+ CA101-3	BATTERY POWER SUPPLY: B+
I CA101-15	RH FUEL LEVEL SENSOR SIGNAL: VARIABLE RESISTANCE
I CA101-16	LH FUEL LEVEL SENSOR SIGNAL: VARIABLE RESISTANCE
S CA102-1	SCP +
S CA102-2	SCP -
PG CA102-12	POWER GROUND: GROUND
PG CA103-11	POWER GROUND: GROUND
PG CA103-12	POWER GROUND: GROUND
SG CA103-23	FUEL LEVEL SENSORS SIGNAL GROUND: GROUND
PG CA103-25	POWER GROUND: GROUND
PG CA103-26	POWER GROUND: GROUND

NOTE: Refer to the Appendix at the rear of this book for Network Messages.

The following abbreviations are used to represent values for Control Module Pin-Out data

I	Input	PG	Power Ground	C	CAN Network	D	Serial and Encoded Data
O	Output	SS	Sensor / Signal Supply V	S	SCP Network	V	Voltage (DC)
B+	Battery Voltage	SG	Sensor / Signal Ground	D2	D2B Network	PWM	Pulse Width Modulated

CAUTION: The information on this data page is furnished to aid the user in understanding circuit operation. THIS INFORMATION SHOULD BE USED FOR REFERENCE ONLY.

NOTE: The values listed are approximately those that can be expected at the control module connector pins with all circuit connections made and all components connected and fitted.

Fig. 07.1

COMPONENTS

Component	Connector(s)	Connector Description	Location
AUXILIARY LIGHTING SWITCH	FC11	10-WAY / YELLOW	FASCIA, ADJACENT TO STEERING COLUMN
ENGINE COOLANT LEVEL SENSOR	CP3	2-WAY / BLACK	ENGINE COMPARTMENT, COOLANT EXPANSION TANK
FUEL LEVEL SENSOR - LH SIDE	FP3	4-WAY / BLACK	FUEL TANK, LH SIDE
FUEL LEVEL SENSOR - RH SIDE	FP4	4-WAY / BLACK	FUEL TANK, RH SIDE
GENERAL ELECTRONIC CONTROL MODULE	FH9 CA24 CA31 FH59 FH60	22-WAY / BLACK 26-WAY / NATURAL 20-WAY / BLACK 12-WAY / BLACK 17-WAY / BLACK	LH 'A' POST
IGNITION SWITCH	FC18	7-WAY / BLACK	STEERING COLUMN COWLING
INSTRUMENT CLUSTER	FC14 FC15 FC63	22-WAY / GREY 20-WAY / BLACK 22-WAY / BLACK	INSTRUMENT PANEL
MAIN LIGHTING SWITCH (COLUMN SWITCHGEAR)	FC116	6-WAY / BLACK	STEERING COLUMN COWLING
OIL PRESSURE SWITCH	PI46	1-WAY / BLACK	ADJACENT TO OIL FILTER
REAR ELECTRONIC CONTROL MODULE	CA63 CA100 CA101 CA102 CA103	17-WAY / BLACK 12-WAY / BLACK 20-WAY / BLACK 22-WAY / BLACK 26-WAY / NATURAL	LUGGAGE COMPARTMENT, RH REAR
WASHER FLUID LEVEL SWITCH	FH37	2-WAY / BLACK	WASHER FLUID CONTAINER

HARNESS IN-LINE CONNECTORS

Connector	Connector Description / Location	Location
CP1	10-WAY / BLACK / INTERCOOLER PUMP LINK LEAD	ENGINE COMPARTMENT, RH FRONT, ADJACENT TO RADIATOR
FC4	14-WAY / GREEN / FASCIA HARNESS IN-LINE CONNECTOR	BEHIND INSTRUMENT PANEL, LH SIDE
FC26	16-WAY / BLUE / CABIN HARNESS TO FASCIA HARNESS	BEHIND INSTRUMENT PANEL, DRIVER SIDE
FP2	8-WAY / BLACK / CABIN HARNESS TO FUEL PUMP HARNESS	TOP OF FUEL TANK, RH SIDE
FP6	2-WAY / BLACK / CABIN HARNESS TO FUEL PUMP HARNESS	TOP OF FUEL TANK, RH SIDE
PI41	42-WAY / BLACK / ENGINE HARNESS TO VEHICLE HARNESSES	ENGINE COMPARTMENT, BULKHEAD, PASSENGER SIDE

GROUNDINGS

Ground	Location
CA156	LUGGAGE COMPARTMENT, RH SIDE
FC38	UNDER CENTER OF INSTRUMENT PANEL, ON TRANSMISSION TUNNEL
FH42	ENGINE COMPARTMENT, BEHIND RH HEADLAMP
FH77	LH LOWER 'A' POST, ADJACENT TO THE GENERAL ELECTRONIC CONTROL MODULE (FORWARD OF CA30)

FOR CONTROL MODULE PIN-OUT INFORMATION, UNFOLD PAGE TO LEFT.

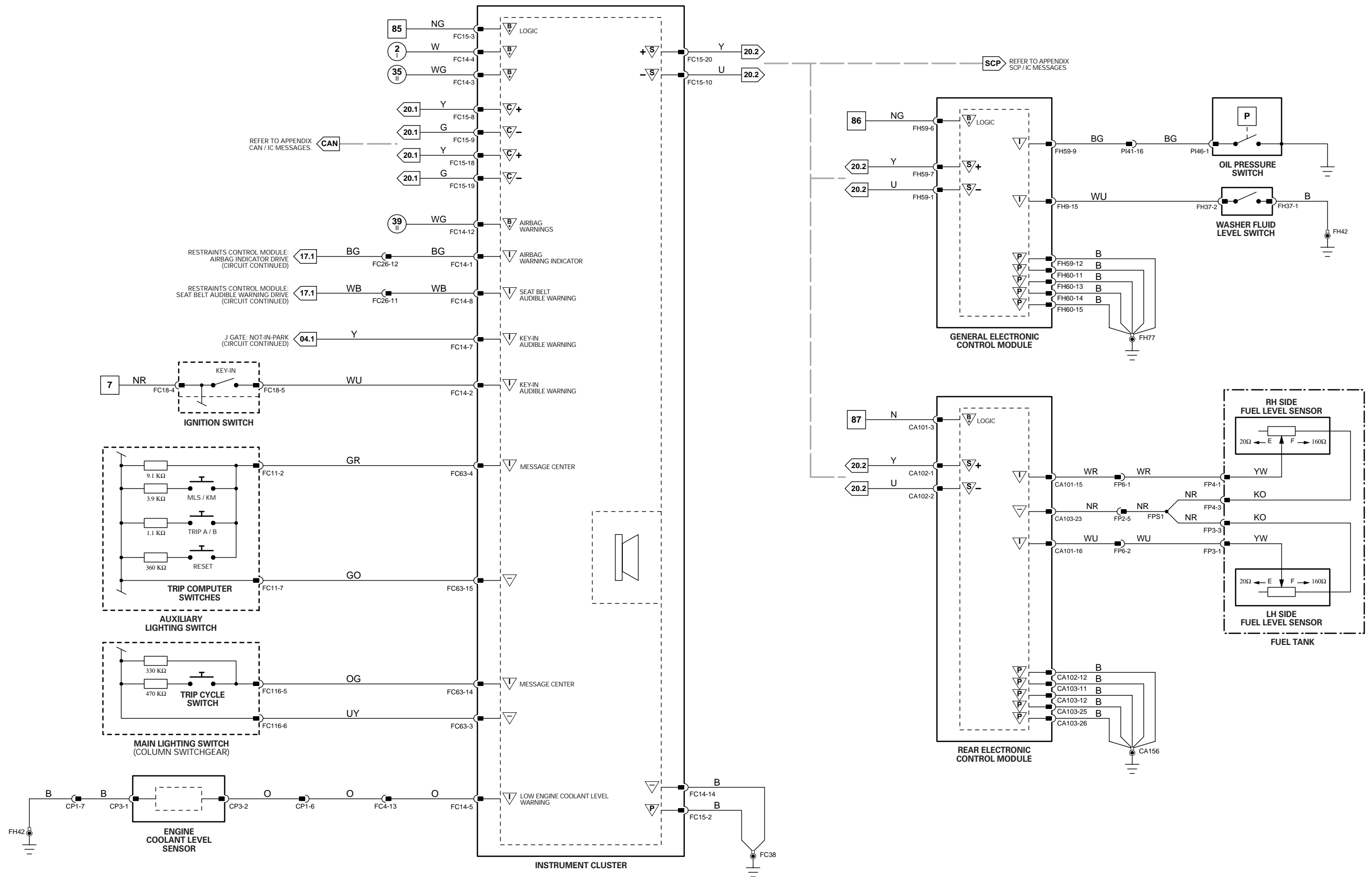

1 → 3 Fig. 01.1	4 → 76 Fig. 01.2	77 → 92 Fig. 01.3	1 → 14 Fig. 01.4	15 → 45 Fig. 01.5	46 → 80 Fig. 01.6	81 → 118 Fig. 01.7	Input Output	Battery Voltage Power Ground	Sensor/Signal Supply V Sensor/Signal Ground	CAN SCP	D2B Network Serial and Encoded Data	VARIANT: All Vehicles VIN RANGE: All DATE OF ISSUE: June 2002
--------------------	---------------------	----------------------	---------------------	----------------------	----------------------	-----------------------	-----------------	---------------------------------	--	------------	--	---

CONTROL MODULE PIN-OUT INFORMATION

General Electronic Control Module

Pin	Description and Characteristic
O FH9-7	LH TURN SIGNAL REPEATER LAMP ACTIVATE: TO ACTIVATE, GECM SWITCHES CIRCUIT TO GROUND (PULSED)
O FH9-11	RH SIDE MARKER LAMP ACTIVATE: TO ACTIVATE, GECM SWITCHES CIRCUIT TO GROUND
O FH9-19	RH TURN SIGNAL REPEATER LAMP ACTIVATE: TO ACTIVATE, GECM SWITCHES CIRCUIT TO GROUND (PULSED)
O FH9-22	LH SIDE MARKER LAMP ACTIVATE: TO ACTIVATE, GECM SWITCHES CIRCUIT TO GROUND
S FH59-1	SCP -
O FH59-2	LH FRONT SIDE LAMP ACTIVATE: TO ACTIVATE, GECM SWITCHES CIRCUIT TO GROUND
O FH59-5	FRONT FOG LAMP RELAY ACTIVATE: TO ACTIVATE, GECM SWITCHES CIRCUIT TO GROUND
B+ FH59-6	BATTERY POWER SUPPLY (LOGIC): B+
S FH59-7	SCP +
O FH59-10	RH FRONT SIDE LAMP ACTIVATE: TO ACTIVATE, GECM SWITCHES CIRCUIT TO GROUND
PG FH59-12	POWER GROUND: GROUND
O FH60-4	RH FRONT TURN SIGNAL ACTIVATE: TO ACTIVATE, GECM SWITCHES CIRCUIT TO GROUND (PULSED)
O FH60-5	LH FRONT TURN SIGNAL ACTIVATE: TO ACTIVATE, GECM SWITCHES CIRCUIT TO GROUND (PULSED)
O FH60-7	RH DIP BEAM ACTIVATE: TO ACTIVATE, GECM SWITCHES CIRCUIT TO GROUND
O FH60-8	LH DIP BEAM ACTIVATE: TO ACTIVATE, GECM SWITCHES CIRCUIT TO GROUND
O FH60-10	RH MAIN BEAM ACTIVATE: TO ACTIVATE, GECM SWITCHES CIRCUIT TO GROUND
PG FH60-11	POWER GROUND: GROUND
PG FH60-13	POWER GROUND: GROUND
PG FH60-14	POWER GROUND: GROUND
PG FH60-15	POWER GROUND: GROUND
O FH60-17	LH MAIN BEAM ACTIVATE: TO ACTIVATE, GECM SWITCHES CIRCUIT TO GROUND

Instrument Cluster

Pin	Description and Characteristic
O FC14-9	HAZARD INDICATOR: PULSED B+
SG FC14-14	SIGNAL GROUND: GROUND
PG FC15-2	POWER GROUND: GROUND
B+ FC15-3	BATTERY POWER SUPPLY (LOGIC): B+
S FC15-10	SCP -
S FC15-20	SCP +
I FC63-1	MAIN LIGHTING SWITCH SIGNALS - TURN SIGNALS, HAZARD WARNING: TURN = VARIABLE RESISTANCE; HAZARD = GROUND
I FC63-2	MAIN LIGHTING SWITCH SIGNALS - EXIT DELAY: VARIABLE RESISTANCE
SG FC63-3	MAIN LIGHTING SWITCH SIGNAL GROUND: GROUND
I FC63-6	FOG LAMPS SWITCH SIGNAL: VARIABLE RESISTANCE
SG FC63-10	AUTOLAMP SENSOR GROUND: GROUND
I FC63-12	MAIN LIGHTING SWITCH SIGNALS - MAIN, FLASH: VARIABLE RESISTANCE
I FC63-13	MAIN LIGHTING SWITCH SIGNALS - OFF, SIDE, DIP, AUTOLAMP: VARIABLE RESISTANCE
SG FC63-15	AUXILIARY LIGHTING SWITCH SIGNAL GROUND: GROUND
I FC63-21	AUTOLAMP SENSOR SIGNAL: VARIABLE RESISTANCE

NOTE: Refer to the Appendix at the rear of this book for Network Messages.

The following abbreviations are used to represent values for Control Module Pin-Out data

I	Input	PG	Power Ground	C	CAN Network	D	Serial and Encoded Data
O	Output	SS	Sensor / Signal Supply V	S	SCP Network	V	Voltage (DC)
B+	Battery Voltage	SG	Sensor / Signal Ground	D2	D2B Network	PWM	Pulse Width Modulated

CAUTION: The information on this data page is furnished to aid the user in understanding circuit operation. THIS INFORMATION SHOULD BE USED FOR REFERENCE ONLY.

NOTE: The values listed are approximately those that can be expected at the control module connector pins with all circuit connections made and all components connected and fitted.

Fig. 08.1

COMPONENTS

Component	Connector(s)	Connector Description	Location
AUXILIARY LIGHTING SWITCH	FC11	10-WAY / YELLOW	FASCIA, ADJACENT TO STEERING COLUMN
CENTER CONSOLE SWITCH PACK	FC113 FC119	8-WAY / BLACK 8-WAY / BLACK	CENTER CONSOLE
DUAL SOLAR SENSOR (AUTO HEADLAMP)	SL1	6-WAY / BLACK	INSTRUMENT PANEL GLARE SHIELD, FRONT CENTER
FRONT FOG LAMP - LH	BF4 BF6	2-WAY / BLACK 2-WAY / BLACK	FRONT BUMPER, LH SIDE
FRONT FOG LAMP - RH	BF5 BF7	2-WAY / BLACK 2-WAY / BLACK	FRONT BUMPER, RH SIDE
FRONT FOG LAMP RELAY	—	—	FRONT POWER DISTRIBUTION FUSE BOX - R11
FRONT POWER DISTRIBUTION FUSE BOX	—	—	ENGINE COMPARTMENT, RH SIDE
GENERAL ELECTRONIC CONTROL MODULE	FH9 CA24 CA31 FH59 FH60	22-WAY / BLACK 26-WAY / NATURAL 20-WAY / BLACK 12-WAY / BLACK 17-WAY / BLACK	LH 'A' POST
HEADLAMP UNIT - LH	HL2 HL3 HL4 HL7 HL8	2-WAY / BLACK 2-WAY / BLACK 2-WAY / BLACK 3-WAY / GREY 2-WAY / BLACK	ENGINE COMPARTMENT, LH FRONT
HEADLAMP UNIT - RH	HR2 HR3 HR4 HR7 HR8	2-WAY / BLACK 2-WAY / BLACK 2-WAY / BLACK 3-WAY / GREY 2-WAY / BLACK	ENGINE COMPARTMENT, RH FRONT
INSTRUMENT CLUSTER	FC14 FC15 FC63	22-WAY / GREY 20-WAY / BLACK 22-WAY / BLACK	INSTRUMENT PANEL
MAIN LIGHTING SWITCH (COLUMN SWITCHGEAR)	FC116	6-WAY / BLACK	STEERING COLUMN COWLING
SIDE MARKER - LH	BF2	2-WAY / BLACK	FRONT BUMPER, LH SIDE
SIDE MARKER - RH	BF3	2-WAY / BLACK	FRONT BUMPER, RH SIDE
TURN REPEATER - LH	FH62	2-WAY / BLACK	LH FRONT FENDER
TURN REPEATER - RH	FH76	2-WAY / BLACK	RH FRONT FENDER

HARNESS IN-LINE CONNECTORS

Connector	Connector Description / Location	Location
BF1	6-WAY / GREY / FRONT HARNESS TO FRONT BUMPER HARNESS	BEHIND FRONT BUMPER, LH SIDE
FH40	12-WAY / GREY / FRONT HARNESS TO LH FRONT HEADLAMP LINK	BEHIND FRONT BUMPER, LH SIDE
FH39	12-WAY / GREY / FRONT HARNESS TO RH FRONT HEADLAMP LINK	BEHIND FRONT BUMPER, RH SIDE
SL3	10-WAY / GREY / FASCIA HARNESS TO SOLAR SENSOR LINK	BEHIND INSTRUMENT PANEL, RH SIDE

GROUND

Ground	Location
FC38	UNDER CENTER OF INSTRUMENT PANEL, ON TRANSMISSION TUNNEL
FH22	ENGINE COMPARTMENT, BEHIND LH HEADLAMP
FH77	LH LOWER 'A' POST, ADJACENT TO THE GENERAL ELECTRONIC CONTROL MODULE (FORWARD OF CA30)

FOR CONTROL MODULE PIN-OUT INFORMATION, UNFOLD PAGE TO LEFT.

Refer to the front of this book for detailed information and illustrations regarding the location and identification of harnesses, relays, fuses, grounds, control modules and control module pins.

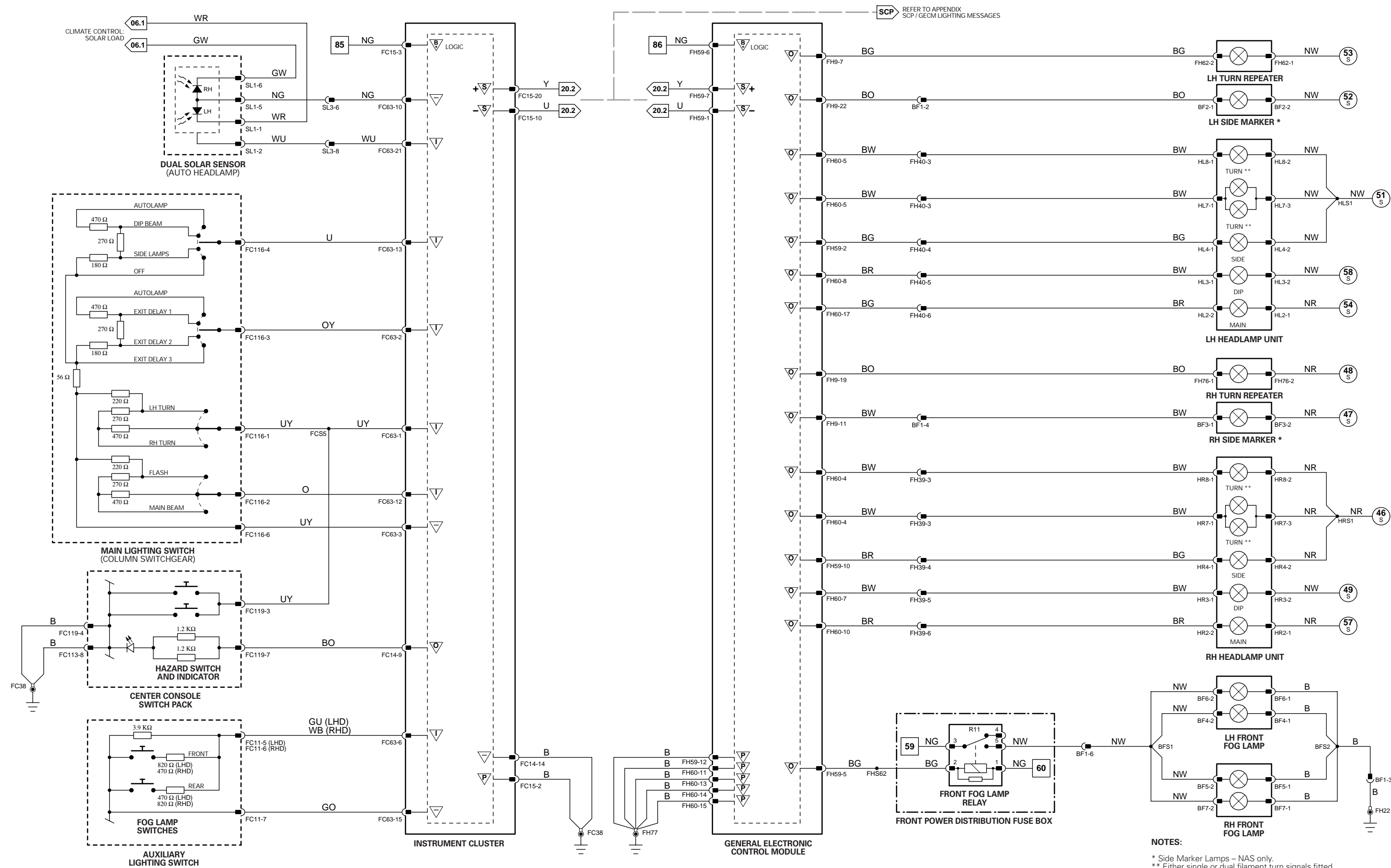

NOTES:
 * Side Marker Lamps – NAS only.
 ** Either single or dual filament turn signals fitted.

CONTROL MODULE PIN-OUT INFORMATION

General Electronic Control Module

Pin	Description and Characteristic
O CA31-20	LH HID RELAY ACTIVATE: TO ACTIVATE, GECM SWITCHES CIRCUIT TO GROUND†
O FH9-6	RH HID RELAY ACTIVATE: TO ACTIVATE, GECM SWITCHES CIRCUIT TO GROUND
O FH9-7	LH TURN SIGNAL REPEATER LAMP ACTIVATE: TO ACTIVATE, GECM SWITCHES CIRCUIT TO GROUND (PULSED)
O FH9-11	RH SIDE MARKER LAMP ACTIVATE: TO ACTIVATE, GECM SWITCHES CIRCUIT TO GROUND
O FH9-19	RH TURN SIGNAL REPEATER LAMP ACTIVATE: TO ACTIVATE, GECM SWITCHES CIRCUIT TO GROUND (PULSED)
O FH9-22	LH SIDE MARKER LAMP ACTIVATE: TO ACTIVATE, GECM SWITCHES CIRCUIT TO GROUND†
S FH59-1	SCP -
O FH59-2	LH FRONT SIDE LAMP ACTIVATE: TO ACTIVATE, GECM SWITCHES CIRCUIT TO GROUND
O FH59-5	FRONT FOG LAMP RELAY ACTIVATE: TO ACTIVATE, GECM SWITCHES CIRCUIT TO GROUND
B+ FH59-6	BATTERY POWER SUPPLY (LOGIC): B+
S FH59-7	SCP +
O FH59-10	RH FRONT SIDE LAMP ACTIVATE: TO ACTIVATE, GECM SWITCHES CIRCUIT TO GROUND
PG FH59-12	POWER GROUND: GROUND
O FH60-4	RH FRONT TURN SIGNAL ACTIVATE: TO ACTIVATE, GECM SWITCHES CIRCUIT TO GROUND (PULSED)
O FH60-5	LH FRONT TURN SIGNAL ACTIVATE: TO ACTIVATE, GECM SWITCHES CIRCUIT TO GROUND (PULSED)
O FH60-10	RH MAIN BEAM ACTIVATE: TO ACTIVATE, GECM SWITCHES CIRCUIT TO GROUND
PG FH60-11	POWER GROUND: GROUND
PG FH60-13	POWER GROUND: GROUND
PG FH60-14	POWER GROUND: GROUND
PG FH60-15	POWER GROUND: GROUND
O FH60-17	LH MAIN BEAM ACTIVATE: TO ACTIVATE, GECM SWITCHES CIRCUIT TO GROUND

Instrument Cluster

Pin	Description and Characteristic
O FC14-9	HAZARD INDICATOR: PULSED B+
SG FC14-14	SIGNAL GROUND: GROUND
PG FC15-2	POWER GROUND: GROUND
B+ FC15-3	BATTERY POWER SUPPLY (LOGIC): B+
S FC15-10	SCP -
S FC15-20	SCP +
I FC63-1	MAIN LIGHTING SWITCH SIGNALS - TURN SIGNALS, HAZARD WARNING: TURN = VARIABLE RESISTANCE; HAZARD = GROUND
I FC63-2	MAIN LIGHTING SWITCH SIGNALS - EXIT DELAY: VARIABLE RESISTANCE
SG FC63-3	MAIN LIGHTING SWITCH SIGNALS - GROUND
I FC63-6	FOG LAMPS SWITCH SIGNAL: VARIABLE RESISTANCE
SG FC63-10	AUTOLAMP SENSOR GROUND: GROUND
I FC63-12	MAIN LIGHTING SWITCH SIGNALS - MAIN, FLASH: VARIABLE RESISTANCE
I FC63-13	MAIN LIGHTING SWITCH SIGNALS - OFF, SIDE, DIP, AUTOLAMP: VARIABLE RESISTANCE
SG FC63-15	AUXILIARY LIGHTING SWITCH SIGNAL GROUND: GROUND
I FC63-21	AUTOLAMP SENSOR SIGNAL: VARIABLE RESISTANCE

NOTE: Refer to the Appendix at the rear of this book for Network Messages.

The following abbreviations are used to represent values for Control Module Pin-Out data

I	Input	PG	Power Ground	C	CAN Network	D	Serial and Encoded Data
O	Output	SS	Sensor / Signal Supply V	S	SCP Network	V	Voltage (DC)
B+	Battery Voltage	SG	Sensor / Signal Ground	D2	D2B Network	PWM	Pulse Width Modulated

CAUTION: The information on this data page is furnished to aid the user in understanding circuit operation. THIS INFORMATION SHOULD BE USED FOR REFERENCE ONLY.

NOTE: The values listed are approximately those that can be expected at the control module connector pins with all circuit connections made and all components connected and fitted.

Fig. 08.2

COMPONENTS

Component	Connector(s)	Connector Description	Location
AUXILIARY LIGHTING SWITCH	FC11	10-WAY / YELLOW	FASCIA, ADJACENT TO STEERING COLUMN
CENTER CONSOLE SWITCH PACK	FC113 FC119	8-WAY / BLACK 8-WAY / BLACK	CENTER CONSOLE
DUAL SOLAR SENSOR (AUTO HEADLAMP)	SL1	6-WAY / BLACK	INSTRUMENT PANEL GLARE SHIELD, FRONT CENTER
FRONT FOG LAMP - LH	BF4 BF6	2-WAY / BLACK 2-WAY / BLACK	FRONT BUMPER, LH SIDE
FRONT FOG LAMP - RH	BF5 BF7	2-WAY / BLACK 2-WAY / BLACK	FRONT BUMPER, RH SIDE
FRONT FOG LAMP RELAY	—	—	FRONT POWER DISTRIBUTION FUSE BOX - R11
FRONT POWER DISTRIBUTION FUSE BOX	—	—	ENGINE COMPARTMENT, RH SIDE
GENERAL ELECTRONIC CONTROL MODULE	FH9 CA24 CA31 FH59 FH60	22-WAY / BLACK 26-WAY / NATURAL 20-WAY / BLACK 12-WAY / BLACK 17-WAY / BLACK	LH 'A' POST
HEADLAMP UNIT - LH	HL2 HL3 HL4 HL6 (HID) HL7 HL8	2-WAY / BLACK 2-WAY / BLACK 2-WAY / BLACK 2-WAY / WHITE 3-WAY / GREY 2-WAY / BLACK	ENGINE COMPARTMENT, LH FRONT
HEADLAMP UNIT - RH	HR2 HR3 HR4 HR6 (HID) HR7 HR8	2-WAY / BLACK 2-WAY / BLACK 2-WAY / BLACK 2-WAY / WHITE 3-WAY / GREY 2-WAY / BLACK	ENGINE COMPARTMENT, RH FRONT
HID RELAY - LH	—	—	FRONT POWER DISTRIBUTION FUSE BOX - R10
HID RELAY - RH	—	—	FRONT POWER DISTRIBUTION FUSE BOX - R13
INSTRUMENT CLUSTER	FC14 FC15 FC63	22-WAY / GREY 20-WAY / BLACK 22-WAY / BLACK	INSTRUMENT PANEL
MAIN LIGHTING SWITCH (COLUMN SWITCHGEAR)	FC116	6-WAY / BLACK	STEERING COLUMN COWLING
SIDE MARKER - LH	BF2	2-WAY / BLACK	FRONT BUMPER, LH SIDE
SIDE MARKER - RH	BF3	2-WAY / BLACK	FRONT BUMPER, RH SIDE
TURN REPEATER - LH	FH62	2-WAY / BLACK	LH FRONT FENDER
TURN REPEATER - RH	FH76	2-WAY / BLACK	RH FRONT FENDER

HARNESS IN-LINE CONNECTORS

Connector	Connector Description / Location	Location
BF1	6-WAY / GREY / FRONT HARNESS TO FRONT BUMPER HARNESS	BEHIND FRONT BUMPER, LH SIDE
FH6	16-WAY GREEN / CABIN HARNESS TO FRONT HARNESS	LH 'A' POST, ADJACENT TO GECM
FH39	12-WAY / GREY / FRONT HARNESS TO RH FRONT HEADLAMP LINK	BEHIND FRONT BUMPER, RH SIDE
FH40	12-WAY / GREY / FRONT HARNESS TO LH FRONT HEADLAMP LINK	BEHIND FRONT BUMPER, LH SIDE
SL3	10-WAY / GREY / FASCIA HARNESS TO SOLAR SENSOR LINK	BEHIND INSTRUMENT PANEL, RH SIDE

GROUNDS

Ground	Location
FC38	UNDER CENTER OF INSTRUMENT PANEL, ON TRANSMISSION TUNNEL
FH22	ENGINE COMPARTMENT, BEHIND LH HEADLAMP
FH42	ENGINE COMPARTMENT, BEHIND RH HEADLAMP
FH77	LH LOWER 'A' POST, ADJACENT TO THE GENERAL ELECTRONIC CONTROL MODULE (FORWARD OF CA30)

FOR CONTROL MODULE PIN-OUT INFORMATION, UNFOLD PAGE TO LEFT.

Refer to the front of this book for detailed information and illustrations regarding the location and identification of harnesses, relays, fuses, grounds, control modules and control module pins.

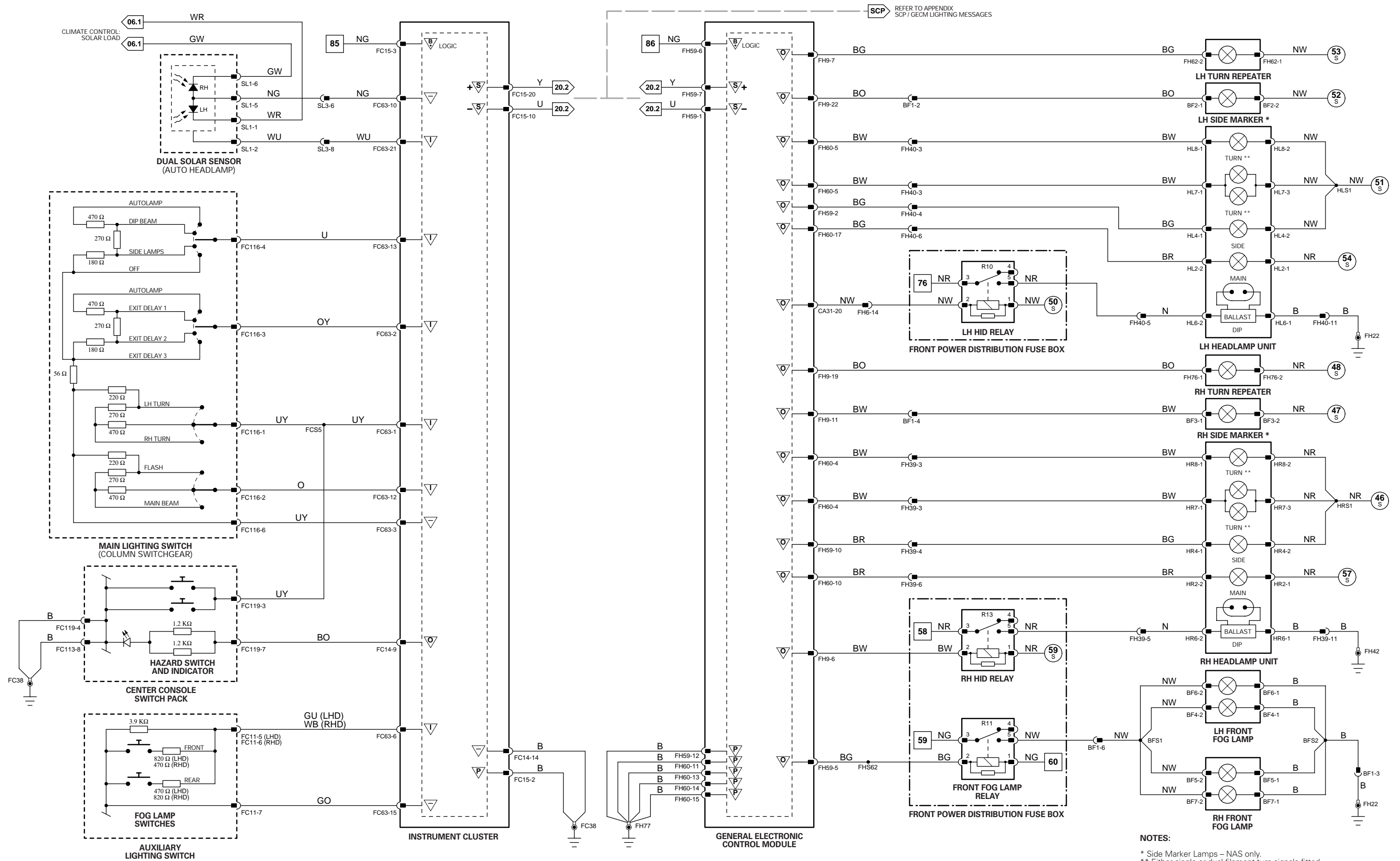

NOTES:
 * Side Marker Lamps - NAS only.
 ** Either single or dual filament turn signals fitted.

CONTROL MODULE PIN-OUT INFORMATION

Instrument Cluster

Pin	Description and Characteristic
O FC14-9	HAZARD INDICATOR: PULSED B+
I FC14-11	REVERSE SWITCH SIGNAL: REVERSE = GROUND
SG FC14-14	SIGNAL GROUND: GROUND
PG FC15-2	POWER GROUND: GROUND
B+ FC15-3	BATTERY POWER SUPPLY (LOGIC): B+
S FC15-10	SCP -
S FC15-20	SCP +
I FC63-1	MAIN LIGHTING SWITCH SIGNALS - TURN SIGNALS, HAZARD WARNING: TURN = VARIABLE RESISTANCE; HAZARD = GROUND
I FC63-2	MAIN LIGHTING SWITCH SIGNALS - EXIT DELAY: VARIABLE RESISTANCE
SG FC63-3	MAIN LIGHTING SWITCH SIGNAL GROUND: GROUND
I FC63-6	FOG LAMPS SWITCH SIGNAL: VARIABLE RESISTANCE
SG FC63-10	AUTOLAMP SENSOR GROUND: GROUND
I FC63-12	MAIN LIGHTING SWITCH SIGNALS - MAIN, FLASH: VARIABLE RESISTANCE
I FC63-13	MAIN LIGHTING SWITCH SIGNALS - OFF, SIDE, DIP, AUTOLAMP: VARIABLE RESISTANCE
SG FC63-15	AUXILIARY LIGHTING SWITCH SIGNAL GROUND: GROUND
I FC63-21	AUTOLAMP SENSOR SIGNAL: VARIABLE RESISTANCE

Rear Electronic Control Module

Pin	Description and Characteristic
O CA63-1	RH STOP LAMP ACTIVATE: TO ACTIVATE, RECM SWITCHES CIRCUIT TO GROUND
O CA63-2	LH STOP LAMP ACTIVATE: TO ACTIVATE, RECM SWITCHES CIRCUIT TO GROUND
O CA63-3	LH REAR TURN SIGNAL ACTIVATE: TO ACTIVATE, RECM SWITCHES CIRCUIT TO GROUND (PULSED)
O CA63-4	RH REAR TURN SIGNAL ACTIVATE: TO ACTIVATE, RECM SWITCHES CIRCUIT TO GROUND (PULSED)
O CA63-5	RH TAIL LAMPS ACTIVATE: TO ACTIVATE, RECM SWITCHES CIRCUIT TO GROUND
O CA63-6	LH TAIL LAMPS ACTIVATE: TO ACTIVATE, RECM SWITCHES CIRCUIT TO GROUND
O CA63-7	LH REAR FOG LAMP ACTIVATE: TO ACTIVATE, RECM SWITCHES CIRCUIT TO GROUND
O CA63-8	RH REAR FOG LAMP ACTIVATE: TO ACTIVATE, RECM SWITCHES CIRCUIT TO GROUND
O CA63-9	LH REVERSE LAMP ACTIVATE: TO ACTIVATE, RECM SWITCHES CIRCUIT TO GROUND
O CA63-10	RH REVERSE LAMP ACTIVATE: TO ACTIVATE, RECM SWITCHES CIRCUIT TO GROUND
O CA63-17	HIGH-MOUNTED STOP LAMP ACTIVATE: TO ACTIVATE, RECM SWITCHES CIRCUIT TO GROUND
O CA100-5	LICENSE PLATE LAMPS ACTIVATE: TO ACTIVATE, RECM SWITCHES CIRCUIT TO GROUND
O CA100-6	LH REAR SIDE MARKER LAMP ACTIVATE: TO ACTIVATE, RECM SWITCHES CIRCUIT TO GROUND
O CA100-12	RH REAR SIDE MARKER LAMP ACTIVATE: TO ACTIVATE, RECM SWITCHES CIRCUIT TO GROUND
B+ CA101-3	BATTERY POWER SUPPLY: B+
S CA102-1	SCP +
S CA102-2	SCP -
PG CA102-12	POWER GROUND: GROUND
I CA102-13	BRAKE ON / OFF SWITCH (NORMALLY OPEN): OPEN CIRCUIT / B+
PG CA103-11	POWER GROUND: GROUND
PG CA103-12	POWER GROUND: GROUND
PG CA103-25	POWER GROUND: GROUND
PG CA103-26	POWER GROUND: GROUND

NOTE: Refer to the Appendix at the rear of this book for Network Messages.

The following abbreviations are used to represent values for Control Module Pin-Out data

I	Input	PG	Power Ground	C	CAN Network	D	Serial and Encoded Data
O	Output	SS	Sensor / Signal Supply V	S	SCP Network	V	Voltage (DC)
B+	Battery Voltage	SG	Sensor / Signal Ground	D2	D2B Network	PWM	Pulse Width Modulated

CAUTION: The information on this data page is furnished to aid the user in understanding circuit operation. THIS INFORMATION SHOULD BE USED FOR REFERENCE ONLY.

NOTE: The values listed are approximately those that can be expected at the control module connector pins with all circuit connections made and all components connected and fitted.

Fig. 08.3

COMPONENTS

Component	Connector(s)	Connector Description	Location
AUXILIARY LIGHTING SWITCH	FC11	10-WAY / YELLOW	FASCIA, ADJACENT TO STEERING COLUMN
BRAKE ON / OFF SWITCH	CA37	2-WAY / GREEN	TOP OF BRAKE PEDAL
CENTER CONSOLE SWITCH PACK	FC113	8-WAY / BLACK	CENTER CONSOLE
	FC119	8-WAY / BLACK	
DUAL SOLAR SENSOR (AUTO HEADLAMP)	SL1	6-WAY / BLACK	INSTRUMENT PANEL GLARE SHIELD, FRONT CENTER
HIGH-MOUNTED STOP LAMP	CA18	3-WAY / GREY	PARCEL SHELF, CENTER
INSTRUMENT CLUSTER	FC14	22-WAY / GREY	INSTRUMENT PANEL
	FC15	20-WAY / BLACK	
	FC63	22-WAY / BLACK	
	CA66	4-WAY / BLACK	
LICENSE PLATE LAMPS	CA67	2-WAY / BLACK	LUGGAGE COMPARTMENT LID
	FC116	6-WAY / BLACK	STEERING COLUMN COWLING
MAIN LIGHTING SWITCH (COLUMN SWITCHGEAR)	CA63	17-WAY / BLACK	LUGGAGE COMPARTMENT, RH REAR
REAR ELECTRONIC CONTROL MODULE	CA100	12-WAY / BLACK	
REVERSE SWITCH	CA101	20-WAY / BLACK	TRANSMISSION, LH REAR
	CA102	22-WAY / BLACK	
	CA103	26-WAY / NATURAL	
	GB5	2-WAY / BLACK	
SIDE MARKER LAMP - LH	BR6	2-WAY / BLACK	REAR BUMPER, LH SIDE
SIDE MARKER LAMP - RH	BR7	2-WAY / BLACK	REAR BUMPER, RH SIDE
TAIL LAMP UNIT - LH	CA10	7-WAY / BLACK	LUGGAGE COMPARTMENT, LH REAR
TAIL LAMP UNIT - RH	CA68	7-WAY / BLACK	LUGGAGE COMPARTMENT, RH REAR

HARNESS IN-LINE CONNECTORS

Connector	Connector Description / Location	Location
BR1	10-WAY / GREY / CABIN HARNESS TO REAR BUMPER HARNESS	BEHIND REAR BUMPER, RH SIDE
FC12	14-WAY / GREY / FASCIA HARNESS TO FRONT HARNESS	BEHIND INSTRUMENT PANEL, PASSENGER SIDE
GB1	16-WAY / GREY / ENGINE HARNESS TO TRANSMISSION HARNESS	ADJACENT TO TRANSMISSION BELL HOUSING
PI41	42-WAY / BLACK / ENGINE HARNESS TO VEHICLE HARNESSES	ENGINE COMPARTMENT, BULKHEAD, PASSENGER SIDE
SL3	10-WAY / GREY / FASCIA HARNESS TO SOLAR SENSOR LINK	BEHIND INSTRUMENT PANEL, RH SIDE

GROUND

Ground	Location
CA116	BEHIND REAR SEAT BACK, RH SIDE
CA156	LUGGAGE COMPARTMENT, RH SIDE
FC38	UNDER CENTER OF INSTRUMENT PANEL, ON TRANSMISSION TUNNEL
PI40 (LHD)	ENGINE COMPARTMENT, BEHIND RH WHEEL ARCH LINER
PI40 (RHD)	ENGINE COMPARTMENT, BEHIND LH WHEEL ARCH LINER

FOR CONTROL MODULE PIN-OUT INFORMATION, UNFOLD PAGE TO LEFT.

Refer to the front of this book for detailed information and illustrations regarding the location and identification of harnesses, relays, fuses, grounds, control modules and control module pins.

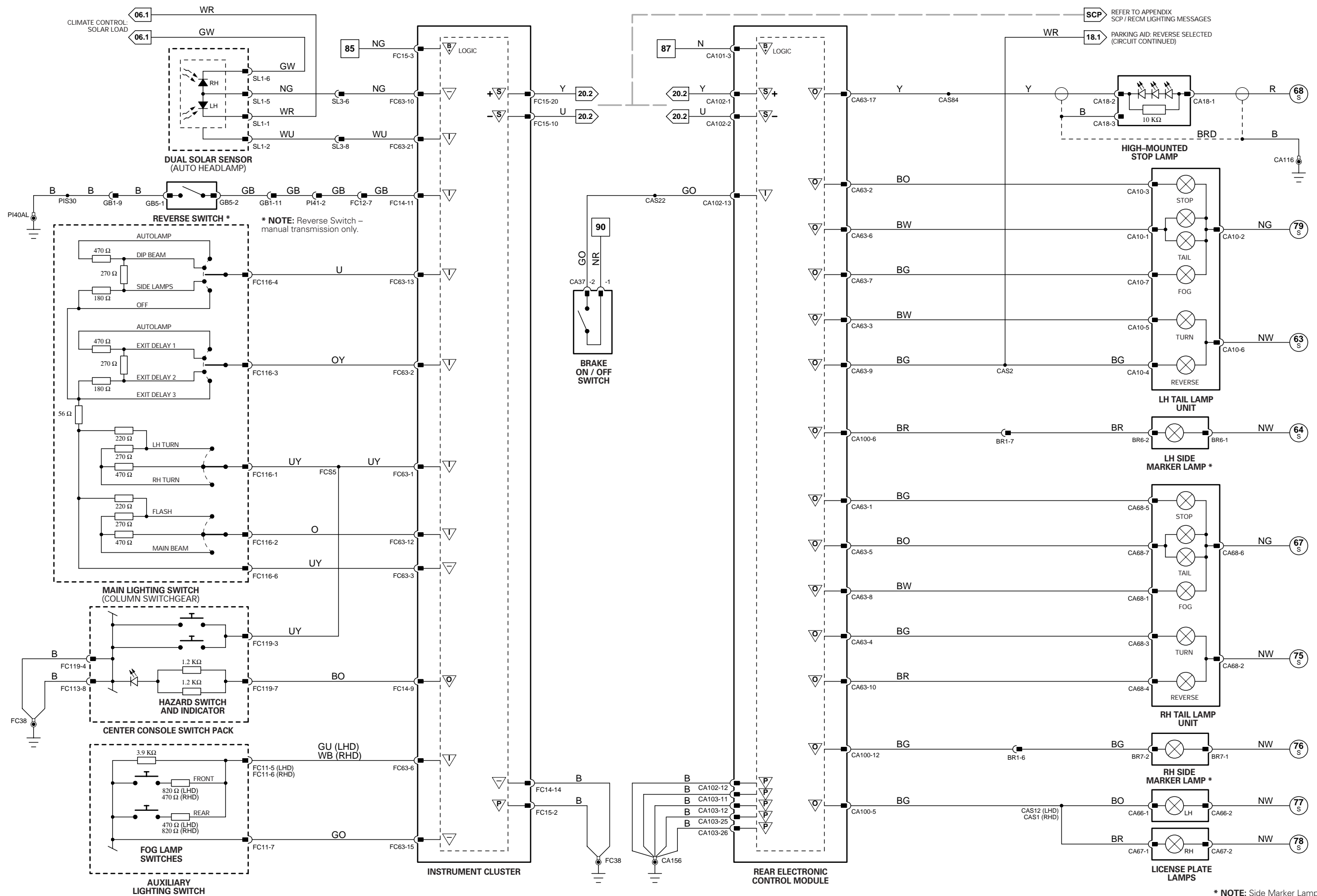

* NOTE: Side Marker Lamps - NAS only.

CONTROL MODULE PIN-OUT INFORMATION

Rear Electronic Control Module

Pin	Description and Characteristic
CA100-5	LICENSE PLATE LAMPS ACTIVATE: TO ACTIVATE, RECM SWITCHES CIRCUIT TO GROUND
TT2-1	RH STOP LAMP ACTIVATE: TO ACTIVATE, RECM SWITCHES CIRCUIT TO GROUND
TT2-2	LH STOP LAMP ACTIVATE: TO ACTIVATE, RECM SWITCHES CIRCUIT TO GROUND
TT2-3	LH REAR TURN SIGNAL ACTIVATE: TO ACTIVATE, RECM SWITCHES CIRCUIT TO GROUND (PULSED)
TT2-4	RH REAR TURN SIGNAL ACTIVATE: TO ACTIVATE, RECM SWITCHES CIRCUIT TO GROUND (PULSED)
TT2-5	RH TAIL LAMPS ACTIVATE: TO ACTIVATE, RECM SWITCHES CIRCUIT TO GROUND
TT2-6	LH TAIL LAMPS ACTIVATE: TO ACTIVATE, RECM SWITCHES CIRCUIT TO GROUND
TT2-9	LH REVERSE LAMP ACTIVATE: TO ACTIVATE, RECM SWITCHES CIRCUIT TO GROUND
TT2-10	RH REVERSE LAMP ACTIVATE: TO ACTIVATE, RECM SWITCHES CIRCUIT TO GROUND
TT2-17	HIGH-MOUNTED STOP LAMP ACTIVATE: TO ACTIVATE, RECM SWITCHES CIRCUIT TO GROUND

Fig. 08.4

COMPONENTS

Component	Connector(s)	Connector Description	Location
BATTERY	—	—	LUGGAGE COMPARTMENT
HIGH-MOUNTED STOP LAMP	CA18	3-WAY / GREY	PARCEL SHELF, CENTER
LICENSE PLATE LAMPS	CA66 CA67	4-WAY / BLACK 2-WAY / BLACK	LUGGAGE COMPARTMENT LID
REAR ELECTRONIC CONTROL MODULE	CA63 CA100 CA101 CA102 CA103	17-WAY / BLACK 12-WAY / BLACK 20-WAY / BLACK 22-WAY / BLACK 26-WAY / NATURAL	LUGGAGE COMPARTMENT, RH REAR
TAIL LAMP UNIT – LH	CA10	7-WAY / BLACK	LUGGAGE COMPARTMENT, LH REAR
TAIL LAMP UNIT – RH	CA68	7-WAY / BLACK	LUGGAGE COMPARTMENT, RH REAR
TRAILER TOWING CONNECTOR	TJ2	NOT AVAILABLE	LUGGAGE COMPARTMENT
TRAILER TOWING CONNECTORS	TJ3 TJ4	NOT AVAILABLE NOT AVAILABLE	LUGGAGE COMPARTMENT
TRAILER TOWING CONTROL MODULE	TT7 TT8	NOT AVAILABLE NOT AVAILABLE	LUGGAGE COMPARTMENT
TRAILER TOWING JUNCTION BOX	TT5	NOT AVAILABLE	LUGGAGE COMPARTMENT
TRAILER TOWING RELAY	TT6	RELAY CONNECTOR	LUGGAGE COMPARTMENT

HARNESS IN-LINE CONNECTORS

Connector	Connector Description / Location	Location
BR1	10-WAY / GREY / CABIN HARNESS TO REAR BUMPER HARNESS	BEHIND REAR BUMPER, RH SIDE
TT1	6-WAY / GREY / TRAILER TOWING IN-LINE CONNECTOR	LUGGAGE COMPARTMENT, ADJACENT TO RH TAIL LAMP

GROUND

Ground	Location
CA116	BEHIND REAR SEAT BACK, RH SIDE
JB1	LUGGAGE COMPARTMENT, BATTERY GROUND
TT4	NOT AVAILABLE

FOR CONTROL MODULE PIN-OUT INFORMATION, UNFOLD PAGE TO LEFT.

The following abbreviations are used to represent values for Control Module Pin-Out data

I	Input	PG	Power Ground	C	CAN Network	D	Serial and Encoded Data
O	Output	SS	Sensor / Signal Supply V	S	SCP Network	V	Voltage (DC)
B+	Battery Voltage	SG	Sensor / Signal Ground	D2	D2B Network	PWM	Pulse Width Modulated

CAUTION: The information on this data page is furnished to aid the user in understanding circuit operation. THIS INFORMATION SHOULD BE USED FOR REFERENCE ONLY.

NOTE: The values listed are approximately those that can be expected at the control module connector pins with all circuit connections made and all components connected and fitted.

Refer to the front of this book for detailed information and illustrations regarding the location and identification of harnesses, relays, fuses, grounds, control modules and control module pins.

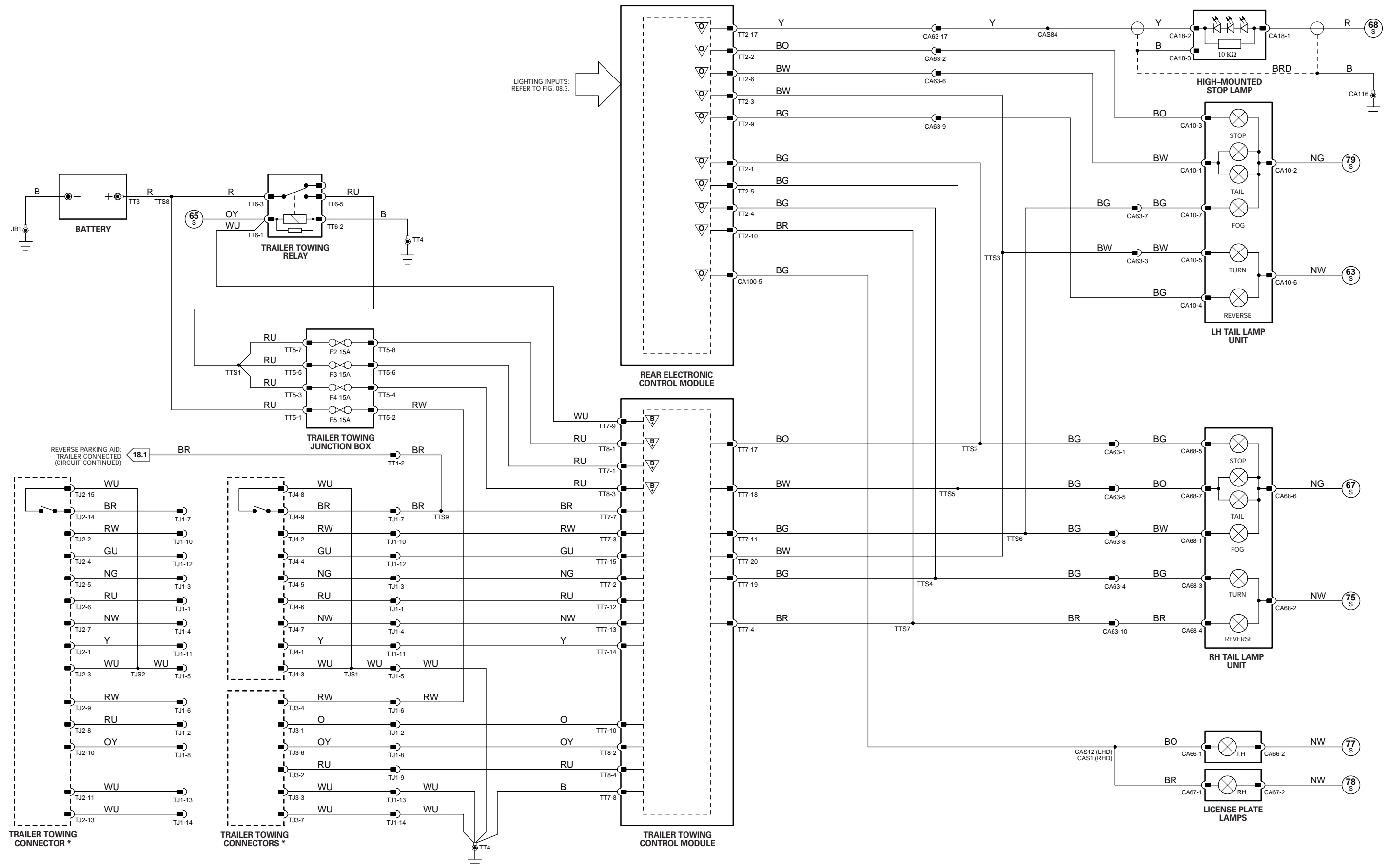

* NOTE: Either single connector or two connectors fitted.

1 → 3 Fig. 01.1	4 → 76 Fig. 01.2	77 → 92 Fig. 01.3	1 → 14 Fig. 01.4	15 → 45 Fig. 01.5	46 → 80 Fig. 01.6	81 → 118 Fig. 01.7	Input	Battery Voltage	Sensor/Signal Supply V	CAN	D2B Network
							Output	Power Ground	Sensor/Signal Ground	SCP	Serial and Encoded Data

VARIANT: Trailer Towing Vehicles
 VIN RANGE: All
 DATE OF ISSUE: June 2002

COMPONENTS

Component	Connector(s)	Connector Description	Location
AUXILIARY LIGHTING SWITCH	FC11	10-WAY / YELLOW	FASCIA, ADJACENT TO STEERING COLUMN
HEADLAMP LEVELING ACTUATOR - LH	HL1	3-WAY / BLACK	BEHIND LH HEADLAMP UNIT
HEADLAMP LEVELING ACTUATOR - RH	HR1	3-WAY / BLACK	BEHIND RH HEADLAMP UNIT
HEADLAMP LEVELING CONTROL MODULE	FH12	26-WAY / BLACK	RH 'A' POST, ABOVE PRIMARY JUNCTION FUSE BOX
HID HEADLAMP UNIT - LH	HL10	4-WAY / BLACK	ENGINE COMPARTMENT, LH FRONT
HID HEADLAMP UNIT - RH	HR10	4-WAY / BLACK	ENGINE COMPARTMENT, RH FRONT
RIDE HEIGHT SENSOR - FRONT AXLE	FH113	6-WAY / BLACK	RH FRONT SUSPENSION
RIDE HEIGHT SENSOR - REAR AXLE	CA240	6-WAY / BLACK	RH REAR SUSPENSION

HARNESS IN-LINE CONNECTORS

Connector	Connector Description / Location	Location
FC4	14-WAY / GREEN / FASCIA HARNESS IN-LINE CONNECTOR	BEHIND INSTRUMENT PANEL, LH SIDE
FH2	16-WAY / GREY / CABIN HARNESS TO FRONT HARNESS	RH 'A' POST, LOWER
FH39	12-WAY / GREY / FRONT HARNESS TO RH FRONT HEADLAMP LINK	BEHIND FRONT BUMPER, RH SIDE
FH40	12-WAY / GREY / FRONT HARNESS TO LH FRONT HEADLAMP LINK	BEHIND FRONT BUMPER, LH SIDE

GROUNDS

Ground	Location
FC38	UNDER CENTER OF INSTRUMENT PANEL, ON TRANSMISSION TUNNEL
FH22	ENGINE COMPARTMENT, BEHIND LH HEADLAMP
FH42	ENGINE COMPARTMENT, BEHIND RH HEADLAMP

Refer to the front of this book for detailed information and illustrations regarding the location and identification of harnesses, relays, fuses, grounds, control modules and control module pins.

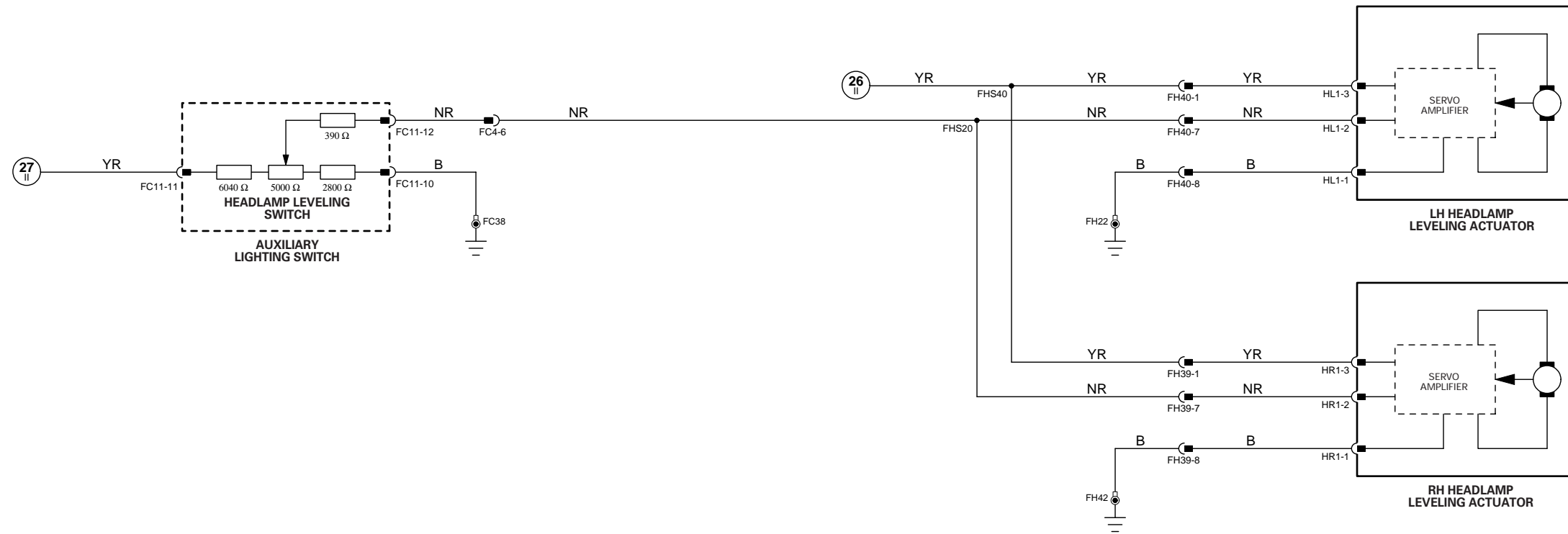

DRIVER-CONTROLLED HEADLAMP LEVELING

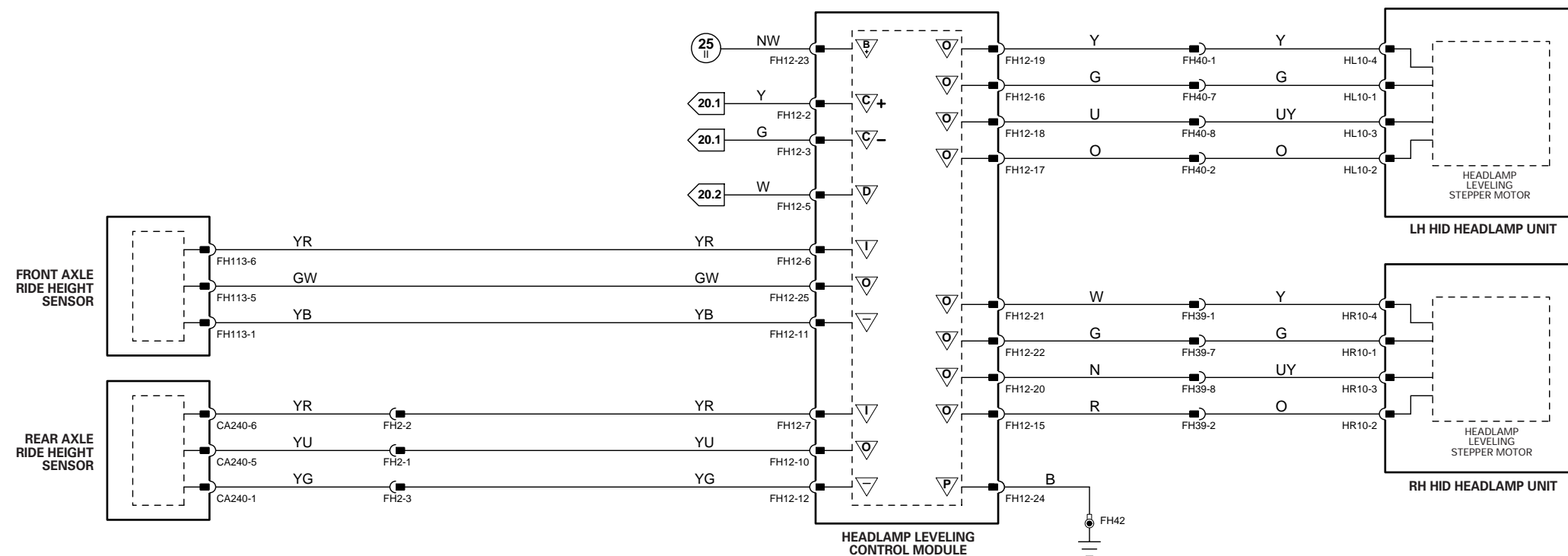

AUTOMATIC HEADLAMP LEVELING (HID HEADLAMPS)

CONTROL MODULE PIN-OUT INFORMATION

Driver Door Control Module

Pin	Description and Characteristic
S CA85-3	SCP +
S CA85-4	SCP -
PG CA85-8	POWER GROUND: GROUND
B+ CA85-11	BATTERY POWER SUPPLY: B+
I DT2-16	DRIVER DOOR ALARM SET / LOCK SWITCH (NORMALLY OPEN): OPEN CIRCUIT / GROUND
I DT2-17	DRIVER DOOR ALARM RESET / UNLOCK SWITCH (NORMALLY OPEN): OPEN CIRCUIT / GROUND

General Electronic Control Module

Pin	Description and Characteristic
I CA24-15	PASSENGER DOOR AJAR SWITCH (NORMALLY OPEN): OPEN CIRCUIT / GROUND
I CA31-8	DRIVER DOOR AJAR SWITCH (NORMALLY OPEN): OPEN CIRCUIT / GROUND
- CA31-12	INTERIOR LIGHTING ACTIVATE: TO ACTIVATE, GECM SWITCHES CIRCUIT TO GROUND (PWM)
S FH59-1	SCP -
B+ FH59-6	BATTERY POWER SUPPLY (LOGIC): B+
S FH59-7	SCP +
PG FH60-11	POWER GROUND: GROUND

Instrument Cluster

Pin	Description and Characteristic
SG FC14-13	ROOF CONSOLE COURTESY LAMP SWITCH GROUND: SWITCH OPEN = GROUND
SG FC14-14	SIGNAL GROUND: GROUND
PG FC15-2	POWER GROUND: GROUND
B+ FC15-3	BATTERY POWER SUPPLY (LOGIC): B+
S FC15-10	SCP -
S FC15-20	SCP +

Rear Electronic Control Module

Pin	Description and Characteristic
O CA100-11	TRUNK LAMPS ACTIVATE: TO ACTIVATE, RECM SWITCHES CIRCUIT TO GROUND
B+ CA101-3	BATTERY POWER SUPPLY: B+
I CA101-17	LHD - RH REAR DOOR AJAR SWITCH (NORMALLY OPEN): OPEN CIRCUIT / GROUND RHD - LH REAR DOOR AJAR SWITCH (NORMALLY OPEN): OPEN CIRCUIT / GROUND
S CA102-1	SCP +
S CA102-2	SCP -
PG CA102-12	POWER GROUND: GROUND
I CA102-14	TRUNK AJAR SWITCH (NORMALLY OPEN): OPEN CIRCUIT / GROUND
I CA103-16	LHD - LH REAR DOOR AJAR SWITCH (NORMALLY OPEN): OPEN CIRCUIT / GROUND RHD - RH REAR DOOR AJAR SWITCH (NORMALLY OPEN): OPEN CIRCUIT / GROUND

NOTE: Refer to the Appendix at the rear of this book for Network Messages.

The following abbreviations are used to represent values for Control Module Pin-Out data

I	Input	PG	Power Ground	C	CAN Network	D	Serial and Encoded Data
O	Output	SS	Sensor / Signal Supply V	S	SCP Network	V	Voltage (DC)
B+	Battery Voltage	SG	Sensor / Signal Ground	D2	D2B Network	PWM	Pulse Width Modulated

CAUTION: The information on this data page is furnished to aid the user in understanding circuit operation. THIS INFORMATION SHOULD BE USED FOR REFERENCE ONLY.

NOTE: The values listed are approximately those that can be expected at the control module connector pins with all circuit connections made and all components connected and fitted.

Fig. 09.1

COMPONENTS

Component	Connector(s)	Connector Description	Location
COURTESY LAMP - DRIVER DOOR	DD6	2-WAY / BLACK	DRIVER DOOR CASING
COURTESY LAMP - PASSENGER DOOR	PD3	2-WAY / BLACK	PASSENGER DOOR CASING
DOOR LATCH ASSEMBLY - DRIVER	DT5	10-WAY / BLACK	DRIVER DOOR
DOOR LATCH ASSEMBLY - PASSENGER	PT3	10-WAY / BLACK	PASSENGER DOOR
DOOR LATCH ASSEMBLY - LH REAR	CA81	10-WAY / BLACK	LH REAR DOOR
DOOR LATCH ASSEMBLY - RH REAR	CA90	10-WAY / BLACK	RH REAR DOOR
DRIVER DOOR CONTROL MODULE	CA85 DD4 DT2	12-WAY / BLACK 26-WAY / NATURAL 20-WAY / BLACK	DRIVER DOOR
FASCIA LAMP - LH	FC44	2-WAY / WHITE	INSTRUMENT PANEL, LH SIDE
FASCIA LAMP - RH	FC51	2-WAY / WHITE	INSTRUMENT PANEL, RH SIDE
GENERAL ELECTRONIC CONTROL MODULE	FH9 CA24 CA31 FH59 FH60	22-WAY / BLACK 26-WAY / NATURAL 20-WAY / BLACK 12-WAY / BLACK 17-WAY / BLACK	LH 'A' POST
GLOVE BOX LAMP	GL1	2-WAY / BLACK	GLOVE BOX
INSTRUMENT CLUSTER	FC14 FC15 FC63	22-WAY / GREY 20-WAY / BLACK 22-WAY / BLACK	INSTRUMENT PANEL
MAP LAMP - LH REAR	RF20	3-WAY / BLACK	LH REAR ASSIST HANDLE
MAP LAMP - RH REAR	RF23	3-WAY / BLACK	RH REAR ASSIST HANDLE
REAR ELECTRONIC CONTROL MODULE	CA63 CA100 CA101 CA102 CA103	17-WAY / BLACK 12-WAY / BLACK 20-WAY / BLACK 22-WAY / BLACK 26-WAY / NATURAL	LUGGAGE COMPARTMENT, RH REAR
ROOF CONSOLE	CA250	22-WAY / BLACK	ROOF HEADLINER
SUN VISOR LAMP - LH	RF12	2-WAY / BLACK	LH SUN VISOR
SUN VISOR LAMP - RH	RF24	2-WAY / BLACK	RH SUN VISOR
TRUNK AJAR SWITCH	CA117	2-WAY / BLACK	LUGGAGE COMPARTMENT LID
TRUNK LAMP - LH	CA96	2-WAY / BLACK	LUGGAGE COMPARTMENT, LH SIDE
TRUNK LID LAMP	CA167	2-WAY / BLACK	LUGGAGE COMPARTMENT LID

HARNES IN-LINE CONNECTORS

Connector	Connector Description / Location	Location
CA3A/B	14-WAY / GREY / CABIN HARNESS BRIDGE	LUGGAGE COMPARTMENT, LH REAR
DD8	16-WAY / BLUE / CABIN HARNESS TO DRIVER DOOR HARNESS	DRIVER DOOR
DT8	14-WAY / GREY / CABIN HARNESS TO DRIVER DOOR TRIM HARNESS	DRIVER DOOR
FC23	10-WAY / GREY / CABIN HARNESS TO FASCIA HARNESS	BEHIND INSTRUMENT PANEL, LH SIDE
FC33	16-WAY / GREEN / CABIN HARNESS TO FASCIA HARNESS	BEHIND INSTRUMENT PANEL, RH SIDE
FC117	10-WAY / BLACK / STEERING WHEEL CASSETTE	STEERING COLUMN
PD4	10-WAY / GREY / CABIN HARNESS TO PASSENGER DOOR HARNESS	PASSENGER DOOR
PT1	14-WAY / GREY / CABIN HARNESS TO PASSENGER DOOR TRIM HARNESS	PASSENGER DOOR
RF34	16-WAY / GREEN / CABIN HARNESS TO DOOR HARNESS	'D' POST, UNDER PARCEL SHELF

GROUND

Ground	Location
CA30	LH LOWER 'A' POST, ADJACENT TO THE GENERAL ELECTRONIC CONTROL MODULE (REARWARD OF FH77)
CA50	RH LOWER 'A' POST, BELOW PRIMARY JUNCTION FUSE BOX
CA116	BEHIND REAR SEAT BACK, RH SIDE
CA141	UNDER LH FRONT SEAT
CA154	UNDER RH FRONT SEAT
CA156	LUGGAGE COMPARTMENT, RH SIDE
FC38	UNDER CENTER OF INSTRUMENT PANEL, ON TRANSMISSION TUNNEL
FH77	LH LOWER 'A' POST, ADJACENT TO THE GENERAL ELECTRONIC CONTROL MODULE (FORWARD OF CA30)

FOR CONTROL MODULE PIN-OUT INFORMATION, UNFOLD PAGE TO LEFT.

Refer to the front of this book for detailed information and illustrations regarding the location and identification of harnesses, relays, fuses, grounds, control modules and control module pins.

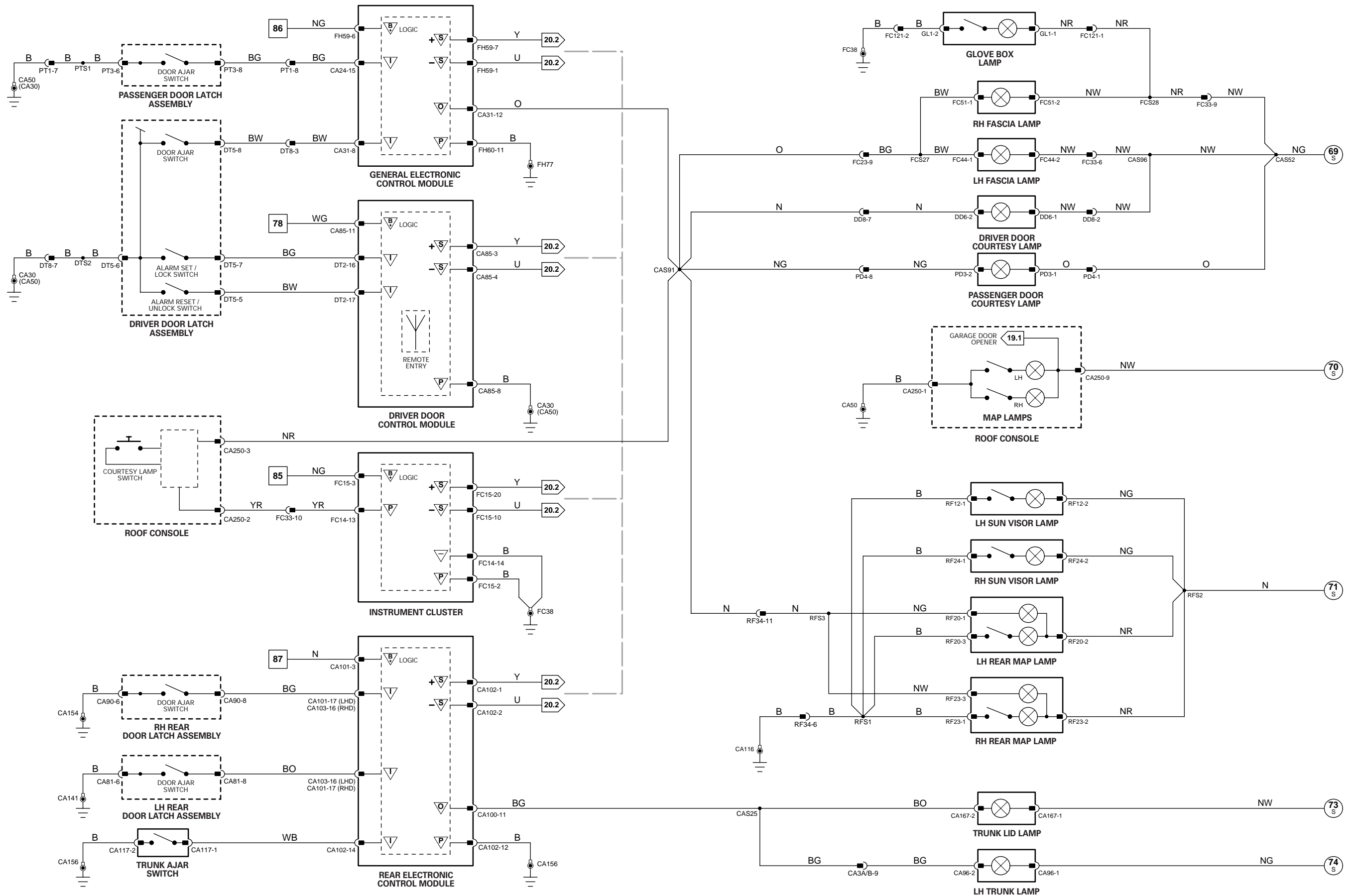

CONTROL MODULE PIN-OUT INFORMATION

Air Conditioning Control Module – Panel

Pin	Description and Characteristic
I FC28-15	PANEL ILLUMINATION (DIMMER CONTROLLED): BRIGHT - APPROX. 11.70V DIM - APPROX. 2.16V

Audio Unit

Pin	Description and Characteristic
I FC94-17	DIMMER CONTROLLED ILLUMINATION: BRIGHT - APPROX. 11.70V DIM - APPROX. 2.16V

General Electronic Control Module

Pin	Description and Characteristic
B+ CA31-1	SWITCHED SYSTEM POWER SUPPLY: B+
O CA31-11	BACKLIGHTING ACTIVATE: BRIGHT - APPROX. 11.70V DIM - APPROX. 2.16V
S FH59-1	SCP -
B+ FH59-6	BATTERY POWER SUPPLY (LOGIC): B+
S FH59-7	SCP +
PG FH59-12	POWER GROUND: GROUND
PG FH60-11	POWER GROUND: GROUND
PG FH60-13	POWER GROUND: GROUND
PG FH60-14	POWER GROUND: GROUND
PG FH60-15	POWER GROUND: GROUND

Instrument Cluster

Pin	Description and Characteristic
SG FC14-14	SIGNAL GROUND: GROUND
I FC14-22	INSTRUMENT CLUSTER LOCATE LIGHTING DRIVE: BRIGHT - APPROX. 11.70V DIM - APPROX. 2.16V
PG FC15-2	POWER GROUND: GROUND
B+ FC15-3	BATTERY POWER SUPPLY (LOGIC): B+
S FC15-10	SCP -
S FC15-20	SCP +
I FC63-2	MAIN LIGHTING SWITCH SIGNALS – EXIT DELAY: OFF, PARKING LIGHTS, DIP BEAM, AND AUTO - APPROX. 5V SHORT EXIT DELAY - APPROX. 3.32V MED. EXIT DELAY - APPROX. 1.89V LONG EXIT DELAY - APPROX. .56V
SG FC63-3	MAIN LIGHTING SWITCH SIGNAL GROUND: GROUND
I FC63-5	DIMMER SIGNAL: BRIGHT - APPROX 0.90V DIM - APPROX 4.50V
I FC63-13	MAIN LIGHTING SWITCH SIGNALS: OFF - APPROX 5.54V SIDE - APPROX 3.60V DIP - APPROX 1.95V AUTOLAMP - APPROX 0.55V
SG FC63-15	AUXILIARY LIGHTING SWITCH SIGNAL GROUND: GROUND
SS FC63-16	DIMMER SUPPLY VOLTAGE: APPROX 4.5V

NOTE: Refer to the Appendix at the rear of this book for Network Messages.

The following abbreviations are used to represent values for Control Module Pin-Out data

I	Input	PG	Power Ground	C	CAN Network	D	Serial and Encoded Data
O	Output	SS	Sensor / Signal Supply V	S	SCP Network	V	Voltage (DC)
B+	Battery Voltage	SG	Sensor / Signal Ground	D2	D2B Network	PWM	Pulse Width Modulated

CAUTION: The information on this data page is furnished to aid the user in understanding circuit operation. THIS INFORMATION SHOULD BE USED FOR REFERENCE ONLY.

NOTE: The values listed are approximately those that can be expected at the control module connector pins with all circuit connections made and all components connected and fitted.

Fig. 09.2

COMPONENTS

Component	Connector(s)	Connector Description	Location
AIR CONDITIONING CONTROL MODULE – PANEL	FC27 FC28	26-WAY / GREY 22-WAY / GREY	CENTER CONSOLE
AUDIO UNIT	FC94 FC96 FC108	20-WAY / BLACK ANTENNA CONNECTOR FIBER OPTIC CONNECTOR	CENTER CONSOLE
AUXILIARY LIGHTING SWITCH	FC11	10-WAY / YELLOW	FASCIA, ADJACENT TO STEERING COLUMN
CENTER CONSOLE SWITCH PACK	FC113 FC119	8-WAY / BLACK 8-WAY / BLACK	CENTER CONSOLE
CIGAR LIGHTER	CA109	3-WAY / BLACK	CENTER CONSOLE
DOOR SWITCH PACK – DRIVER	DD2	26-WAY / YELLOW	DRIVER DOOR ARM REST
FUEL FLAP / TRUNK RELEASE SWITCH PACK	FC43	10-WAY / BLACK	LH LOWER FACIA
GENERAL ELECTRONIC CONTROL MODULE	FH9 CA24 CA31 FH59 FH60	22-WAY / BLACK 26-WAY / NATURAL 20-WAY / BLACK 12-WAY / BLACK 17-WAY / BLACK	LH 'A' POST
INSTRUMENT CLUSTER	FC14 FC15 FC63	22-WAY / GREY 20-WAY / BLACK 22-WAY / BLACK	INSTRUMENT PANEL
J GATE MODULE	CA245	16-WAY / BLACK	J GATE ASSEMBLY
MAIN LIGHTING SWITCH (COLUMN SWITCHGEAR)	FC116	6-WAY / BLACK	STEERING COLUMN COWLING
POWER POINT	CA237	3-WAY / BROWN	ADJACENT TO CIGAR LIGHTER
PRIMARY JUNCTION FUSE BOX	CA2 CA56 FC37 FH7 FH53	26-WAY / BLACK 8-WAY / BLACK 26-WAY / BLACK 6-WAY / BLACK 10-WAY / BLACK	RH 'A' POST
ROOF CONSOLE	CA250	22-WAY / BLACK	ROOF HEADLINER
STEERING WHEEL LIGHTING	SQ1 SQ2	4-WAY / BLACK 6-WAY / BLACK	STEERING WHEEL
TELEMATICS DISPLAY	FC92	22-WAY / BLACK	CENTER CONSOLE
WINDOW SWITCH – LH REAR	CA78	5-WAY / GREEN	LH REAR DOOR ARM REST
WINDOW SWITCH – PASSENGER	PD1	5-WAY / GREEN	PASSENGER DOOR ARM REST
WINDOW SWITCH – RH REAR	CA95	5-WAY / GREEN	RH REAR DOOR ARM REST

HARNESS IN-LINE CONNECTORS

Connector	Connector Description / Location	Location
DD8	16-WAY / BLUE / CABIN HARNESS TO DRIVER DOOR HARNESS	DRIVER DOOR
FC23	10-WAY / GREY / CABIN HARNESS TO FASCIA HARNESS	BEHIND LH FACIA END COVER
FC117	10-WAY / BLACK / STEERING WHEEL CASSETTE	STEERING COLUMN
PD4	10-WAY / GREY / CABIN HARNESS TO PASSENGER DOOR HARNESS	PASSENGER DOOR

GROUND S

Ground	Location
CA30	LH LOWER 'A' POST, ADJACENT TO THE GENERAL ELECTRONIC CONTROL MODULE (REARWARD OF FH77)
CA50	RH LOWER 'A' POST, BELOW PRIMARY JUNCTION FUSE BOX
CA141	UNDER LH FRONT SEAT
CA154	UNDER RH FRONT SEAT
FC38	UNDER CENTER OF INSTRUMENT PANEL, ON TRANSMISSION TUNNEL
FH77	LH LOWER 'A' POST, ADJACENT TO THE GENERAL ELECTRONIC CONTROL MODULE (FORWARD OF CA30)

FOR CONTROL MODULE PIN-OUT INFORMATION, UNFOLD PAGE TO LEFT.

Refer to the front of this book for detailed information and illustrations regarding the location and identification of harnesses, relays, fuses, grounds, control modules and control module pins.

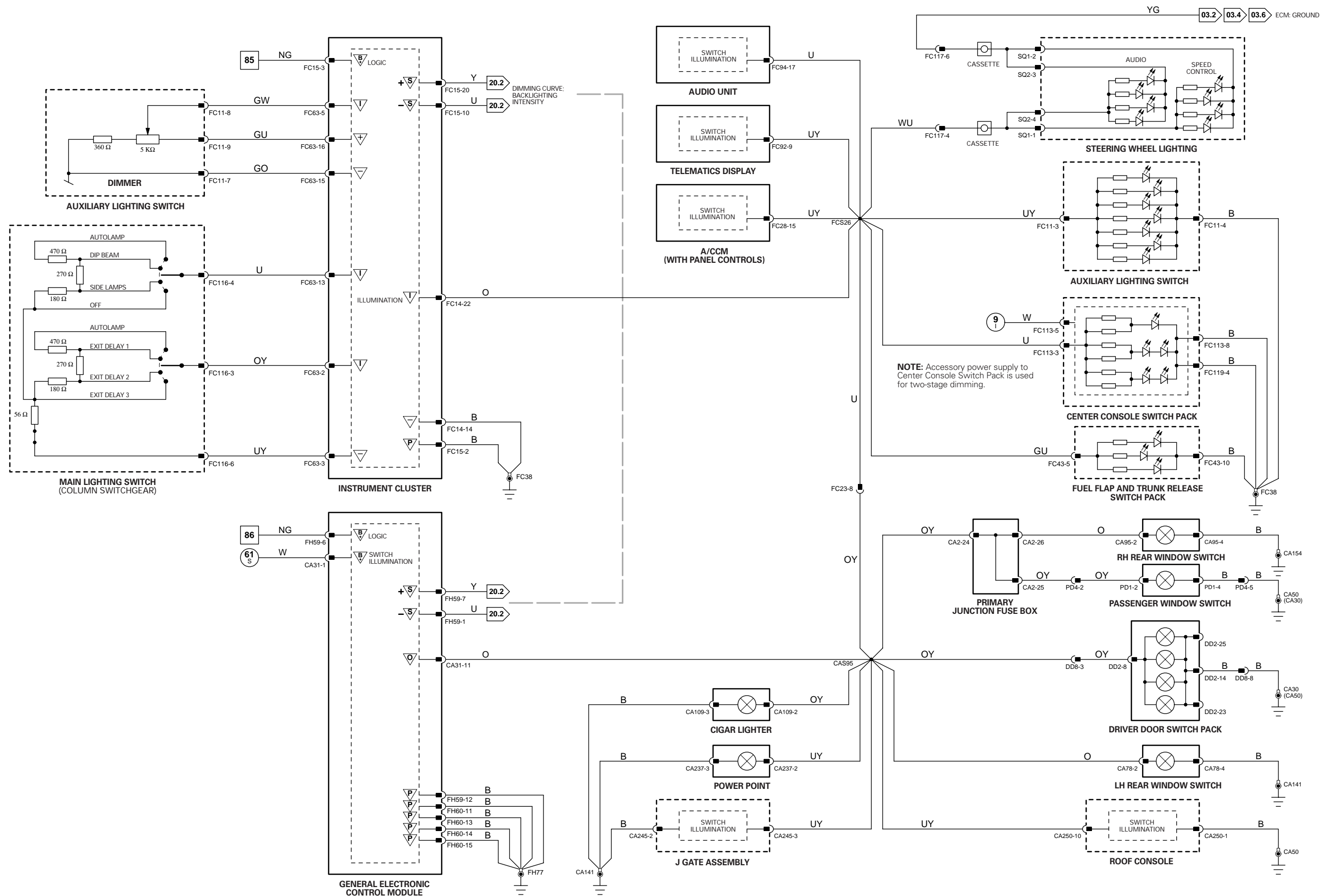

CONTROL MODULE PIN-OUT INFORMATION

Driver Door Control Module

Pin Description and Characteristic

S	CA85-3	SCP +
S	CA85-4	SCP -
PG	CA85-8	POWER GROUND: GROUND
B+	CA85-11	BATTERY POWER SUPPLY: B+
O	DD4-7	MEMORY SET INDICATOR: TO ACTIVATE, DDCM SWITCHES CIRCUIT TO B+
I	DD4-10	MEMORY 1: GROUND WHEN SELECTED
I	DD4-11	MEMORY 2: GROUND WHEN SELECTED
I	DD4-25	MEMORY SET: GROUND WHEN SELECTED

General Electronic Control Module

Pin Description and Characteristic

I	CA24-5	PEDAL ADJUST MOTOR POSITION SENSOR SIGNAL: VARIABLE VOLTAGE
O	CA24-12	PEDAL ADJUST MOTOR DRIVE - IN: TO ACTIVATE, GECM SWITCHES CIRCUIT TO B+
SG	CA24-18	PEDAL ADJUST MOTOR POSITION SENSOR SIGNAL GROUND: GROUND
O	CA24-26	PEDAL ADJUST MOTOR DRIVE - OUT: TO ACTIVATE, GECM SWITCHES CIRCUIT TO B+
I	CA31-8	DRIVER DOOR AJAR SWITCH (NORMALLY OPEN): OPEN CIRCUIT / GROUND
SS	CA31-16	PEDAL ADJUST MOTOR POSITION SENSOR SIGNAL SUPPLY VOLTAGE: NOMINAL 5 V
I	FH9-8	PEDALS OUT REQUEST (NORMALLY OPEN): OPEN CIRCUIT / GROUND
I	FH9-17	PEDALS IN REQUEST (NORMALLY OPEN): OPEN CIRCUIT / GROUND
S	FH59-1	SCP -
S	FH59-7	SCP +
B+	FH60-1	SWITCHED SYSTEM POWER SUPPLY: B+
PG	FH60-11	POWER GROUND: GROUND

Instrument Cluster

Pin Description and Characteristic

SG	FC14-14	SIGNAL GROUND: GROUND
B+	FC15-1	BATTERY POWER SUPPLY (COLUMN MOTOR)
PG	FC15-2	POWER GROUND: GROUND
B+	FC15-3	BATTERY POWER SUPPLY (LOGIC): B+
S	FC15-10	SCP -
O	FC15-11	STEERING COLUMN MOTOR DOWN / IN DRIVE: B+ WHEN ACTIVATED
O	FC15-12	STEERING COLUMN MOTOR UP / OUT DRIVE: B+ WHEN ACTIVATED
O	FC15-13	STEERING COLUMN IN / OUT FUNCTION SOLENOID DRIVE: B+ WHEN ACTIVATED
O	FC15-14	STEERING COLUMN UP / DOWN FUNCTION SOLENOID DRIVE: B+ WHEN ACTIVATED
S	FC15-20	SCP +
I	FC63-7	FUNCTION SELECT SIGNAL: VARIABLE RESISTANCE
SG	FC63-8	STEERING COLUMN POSITION FEEDBACK POTENTIOMETERS SIGNAL GROUND: GROUND
I	FC63-9	STEERING COLUMN IN / OUT POSITION FEEDBACK POTENTIOMETER SIGNAL: VARIABLE VOLTAGE
I	FC63-17	STEERING COLUMN MOVEMENT SWITCH SIGNAL: VARIABLE VOLTAGE
SG	FC63-18	STEERING COLUMN MOVEMENT / SELECT SIGNAL GROUND: GROUND
O	FC63-19	STEERING COLUMN POSITION FEEDBACK POTENTIOMETERS SUPPLY VOLTAGE: B+
I	FC63-20	STEERING COLUMN UP / DOWN POSITION FEEDBACK POTENTIOMETER SIGNAL: VARIABLE VOLTAGE

NOTE: Refer to the Appendix at the rear of this book for Network Messages.

The following abbreviations are used to represent values for Control Module Pin-Out data

I	Input	PG	Power Ground	C	CAN Network	D	Serial and Encoded Data
O	Output	SS	Sensor / Signal Supply V	S	SCP Network	V	Voltage (DC)
B+	Battery Voltage	SG	Sensor / Signal Ground	D2	D2B Network	PWM	Pulse Width Modulated

CAUTION: The information on this data page is furnished to aid the user in understanding circuit operation. THIS INFORMATION SHOULD BE USED FOR REFERENCE ONLY.

NOTE: The values listed are approximately those that can be expected at the control module connector pins with all circuit connections made and all components connected and fitted.

Fig. 10.1

COMPONENTS

Component	Connector(s)	Connector Description	Location
COLUMN AND PEDAL ADJUST SWITCH	FC45	8-WAY / BLACK	STEERING COLUMN COWLING
DOOR LATCH ASSEMBLY - DRIVER	DT5	10-WAY / BLACK	DRIVER DOOR
DOOR SWITCH PACK - DRIVER	DD2	26-WAY / YELLOW	DRIVER DOOR ARM REST
DRIVER DOOR CONTROL MODULE	CA85 DD4 DT2	12-WAY / BLACK 26-WAY / NATURAL 20-WAY / BLACK	DRIVER DOOR
GENERAL ELECTRONIC CONTROL MODULE	FH9 CA24 CA31 FH59 FH60	22-WAY / BLACK 26-WAY / NATURAL 20-WAY / BLACK 12-WAY / BLACK 17-WAY / BLACK	LH 'A' POST
INSTRUMENT CLUSTER	FC14 FC15 FC63	22-WAY / GREY 20-WAY / BLACK 22-WAY / BLACK	INSTRUMENT PANEL
PEDAL ADJUST MOTOR	CA234 CA235	2-WAY / BLACK 3-WAY / BLACK	PEDAL MOUNTING BRACKET ASSEMBLY
STEERING COLUMN MOTOR, SOLENOIDS AND POSITION SENSORS	FC115	10-WAY / BLACK	UPPER STEERING COLUMN

HARNESS IN-LINE CONNECTORS

Connector	Connector Description / Location	Location
DD8	16-WAY / BLUE / CABIN HARNESS TO DRIVER DOOR HARNESS	DRIVER DOOR
DT8	14-WAY / GREY / CABIN HARNESS TO DRIVER DOOR TRIM HARNESS	DRIVER DOOR
FC4	14-WAY / GREEN / FASCIA HARNESS IN-LINE CONNECTOR	BEHIND INSTRUMENT PANEL, LH SIDE

GROUND S

Ground	Location
CA30	LH LOWER 'A' POST, ADJACENT TO THE GENERAL ELECTRONIC CONTROL MODULE (REARWARD OF FH77)
CA50	RH LOWER 'A' POST, BELOW PRIMARY JUNCTION FUSE BOX
FC38	UNDER CENTER OF INSTRUMENT PANEL, ON TRANSMISSION TUNNEL
FH77	LH LOWER 'A' POST, ADJACENT TO THE GENERAL ELECTRONIC CONTROL MODULE (FORWARD OF CA30)

FOR CONTROL MODULE PIN-OUT INFORMATION, UNFOLD PAGE TO LEFT.

Refer to the front of this book for detailed information and illustrations regarding the location and identification of harnesses, relays, fuses, grounds, control modules and control module pins.

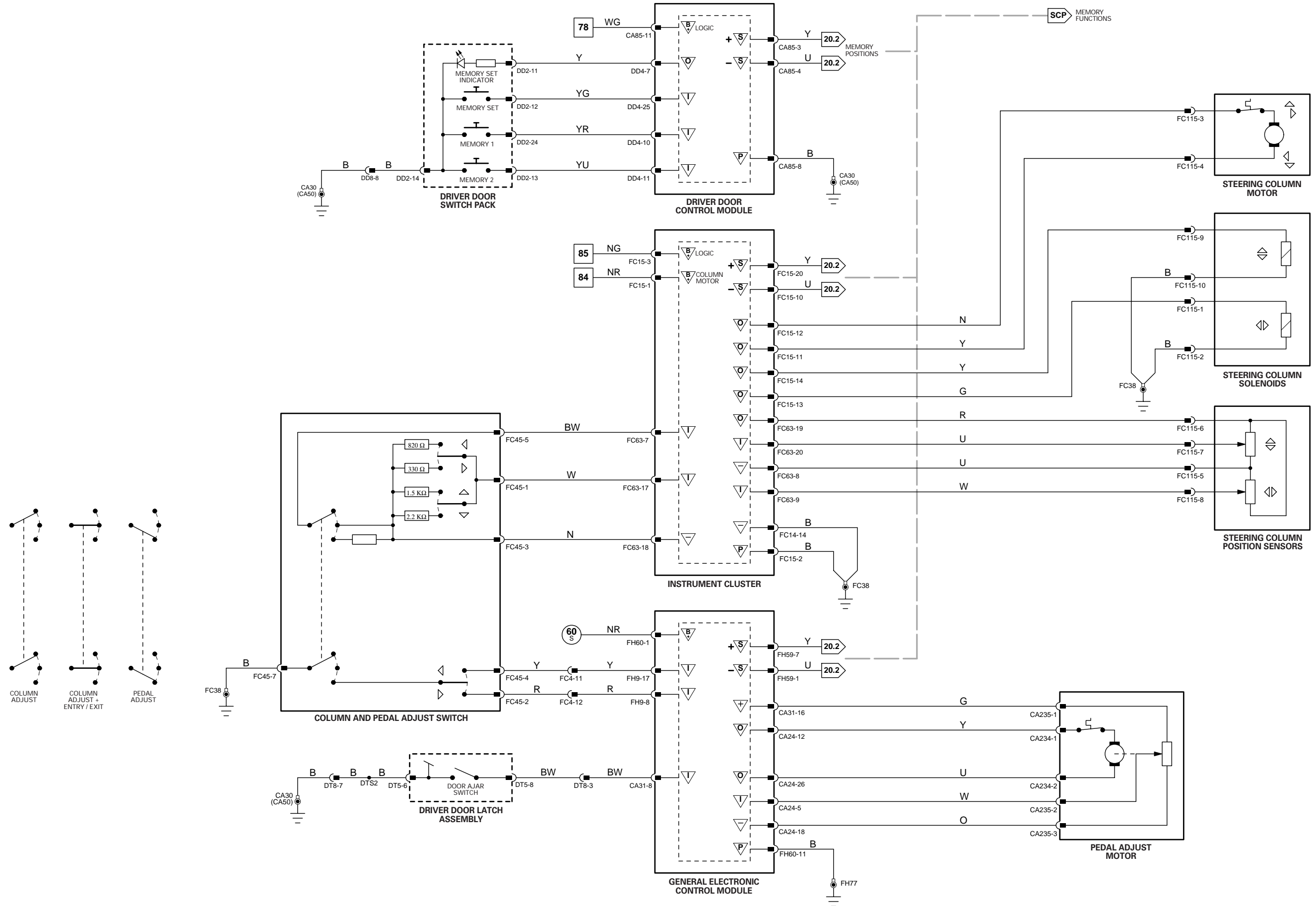

CONTROL MODULE PIN-OUT INFORMATION

Air Conditioning Control Module – Panel

Pin	Description and Characteristic
C FC28-1	CAN -
C FC28-12	CAN

Air Conditioning Control Module – Remote

Pin	Description and Characteristic
C FC41-1	CAN -
C FC41-12	CAN +

Driver Door Control Module

Pin	Description and Characteristic
S CA85-3	SCP +
S CA85-4	SCP -
PG CA85-7	POWER GROUND: GROUND
PG CA85-8	POWER GROUND: GROUND
B+ CA85-11	BATTERY POWER SUPPLY: B+
B+ CA85-12	SWITCHED SYSTEM POWER SUPPLY: B+
I DD4-3	MIRROR MOVEMENT UP: GROUND WHEN ACTIVATED
O DD4-7	MEMORY SET INDICATOR: TO ACTIVATE, DDCM SWITCHES CIRCUIT TO B+
I DD4-10	MEMORY 1: GROUND WHEN SELECTED
I DD4-11	MEMORY 2: GROUND WHEN SELECTED
I DD4-19	MIRROR MOVEMENT RIGHT: GROUND WHEN ACTIVATED
I DD4-20	MIRROR MOVEMENT DOWN: GROUND WHEN ACTIVATED
I DD4-21	MIRROR MOVEMENT LEFT: GROUND WHEN ACTIVATED
I DD4-23	LH DOOR MIRROR MOVEMENT SELECT: GROUND WHEN SELECTED
I DD4-24	RH DOOR MIRROR MOVEMENT SELECT: GROUND WHEN SELECTED
I DD4-25	MEMORY SET: GROUND WHEN SELECTED
O DT2-1	DRIVER DOOR MIRROR LEFT: TO ACTIVATE, DDCM SWITCHES CIRCUIT TO B+
O DT2-2	DRIVER DOOR MIRROR RIGHT: TO ACTIVATE, DDCM SWITCHES CIRCUIT TO B+
O DT2-3	DRIVER DOOR MIRROR UP: TO ACTIVATE, DDCM SWITCHES CIRCUIT TO B+
O DT2-4	DRIVER DOOR MIRROR DOWN: TO ACTIVATE, DDCM SWITCHES CIRCUIT TO B+
SS DT2-5	DRIVER DOOR MIRROR POSITION SENSORS SIGNAL SUPPLY VOLTAGE: B+
I DT2-14	DRIVER DOOR MIRROR LEFT / RIGHT POSITION FEEDBACK SIGNAL: VARIABLE VOLTAGE
I DT2-15	DRIVER DOOR MIRROR UP / DOWN POSITION FEEDBACK SIGNAL: VARIABLE VOLTAGE
SG DT2-19	DRIVER DOOR MIRROR POSITION SENSORS SIGNAL GROUND: GROUND

General Electronic Control Module

Pin	Description and Characteristic
I CA24-7	PASSENGER DOOR MIRROR LEFT / RIGHT POSITION FEEDBACK SIGNAL: VARIABLE VOLTAGE
SS CA24-8	PASSENGER DOOR MIRROR POSITION SENSORS SIGNAL SUPPLY VOLTAGE: B+
I CA24-11	PASSENGER DOOR MIRROR UP / DOWN POSITION FEEDBACK: VARIABLE VOLTAGE
O CA24-20	PASSENGER DOOR MIRROR UP: TO ACTIVATE, GECM SWITCHES CIRCUIT TO B+
O CA24-21	PASSENGER DOOR MIRROR DOWN: TO ACTIVATE, GECM SWITCHES CIRCUIT TO B+
SG CA24-22	PASSENGER DOOR MIRROR POSITION SENSORS SIGNAL GROUND: GROUND
O CA24-23	PASSENGER DOOR MIRROR LEFT: TO ACTIVATE, DDCM SWITCHES CIRCUIT TO B+
O CA24-24	PASSENGER DOOR MIRROR RIGHT: TO ACTIVATE, DDCM SWITCHES CIRCUIT TO B+
S FH59-1	SCP -
S FH59-7	SCP +
B+ FH60-1	SWITCHED SYSTEM POWER SUPPLY: B+
PG FH60-11	POWER GROUND: GROUND

Instrument Cluster

Pin	Description and Characteristic
S FC15-10	SCP -
C FC15-18	CAN +
C FC15-19	CAN -
S FC15-20	SCP +

Rear Electronic Control Module

Pin	Description and Characteristic
B+ CA101-3	BATTERY POWER SUPPLY: B+
S CA102-1	SCP +
S CA102-2	SCP -
O CA102-7	HEATED REAR WINDOW ACTIVATE: TO ACTIVATE, RECM SWITCHES CIRCUIT TO GROUND
PG CA102-12	POWER GROUND: GROUND
B+ CA103-13	SWITCHED SYSTEM POWER SUPPLY: B+

NOTE: Refer to the Appendix at the rear of this book for Network Messages.

The following abbreviations are used to represent values for Control Module Pin-Out data

I	Input	PG	Power Ground	C	CAN Network	D	Serial and Encoded Data
O	Output	SS	Sensor / Signal Supply V	S	SCP Network	V	Voltage (DC)
B+	Battery Voltage	SG	Sensor / Signal Ground	D2	D2B Network	PWM	Pulse Width Modulated

CAUTION: The information on this data page is furnished to aid the user in understanding circuit operation. THIS INFORMATION SHOULD BE USED FOR REFERENCE ONLY.

NOTE: The values listed are approximately those that can be expected at the control module connector pins with all circuit connections made and all components connected and fitted.

Fig. 10.2

COMPONENTS

Component	Connector(s)	Connector Description	Location
AIR CONDITIONING CONTROL MODULE – PANEL	FC27 FC28	26-WAY / GREY 22-WAY / GREY	CENTER CONSOLE
AIR CONDITIONING CONTROL MODULE – REMOTE	FC40 FC41	26-WAY / GREY 22-WAY / GREY	BEHIND INSTRUMENT PANEL, RH SIDE (LHD), LH SIDE (RHD)
DOOR MIRROR – DRIVER	DT6	22-WAY / BLACK	DRIVER DOOR
DOOR MIRROR – PASSENGER	CA19	22-WAY / BLACK	PASSENGER DOOR
DOOR SWITCH PACK – DRIVER	DD2	26-WAY / YELLOW	DRIVER DOOR ARM REST
DRIVER DOOR CONTROL MODULE	CA85 DD4 DT2	12-WAY / BLACK 26-WAY / NATURAL 20-WAY / BLACK	DRIVER DOOR
GENERAL ELECTRONIC CONTROL MODULE	FH9 CA24 CA31 FH59 FH60	22-WAY / BLACK 26-WAY / NATURAL 20-WAY / BLACK 12-WAY / BLACK 17-WAY / BLACK	LH 'A' POST
HEATED REAR WINDOW RELAY	—	—	REAR POWER DISTRIBUTION FUSE BOX – R1
HEATED REAR WINDOW	CA20	2-WAY / GREY	CONNECTOR LOCATED BELOW PARCEL SHELF, LH SIDE
INSTRUMENT CLUSTER	FC14 FC15 FC63	22-WAY / GREY 20-WAY / BLACK 22-WAY / BLACK	INSTRUMENT PANEL
REAR ELECTRONIC CONTROL MODULE	CA63 CA100 CA101 CA102 CA103	17-WAY / BLACK 12-WAY / BLACK 20-WAY / BLACK 22-WAY / BLACK 26-WAY / NATURAL	LUGGAGE COMPARTMENT, RH REAR
REAR POWER DISTRIBUTION FUSE BOX	—	—	LUGGAGE COMPARTMENT

HARNESS IN-LINE CONNECTORS

Connector	Connector Description / Location	Location
CA3A/B	14-WAY / GREY / CABIN HARNESS BRIDGE	LUGGAGE COMPARTMENT, LH REAR
DD8	16-WAY / BLUE / CABIN HARNESS TO DRIVER DOOR HARNESS	DRIVER DOOR
DT8	14-WAY / GREY / CABIN HARNESS TO DRIVER DOOR TRIM HARNESS	DRIVER DOOR

GROUND S

Ground	Location
CA30	LH LOWER 'A' POST, ADJACENT TO THE GENERAL ELECTRONIC CONTROL MODULE (REARWARD OF FH77)
CA50	RH LOWER 'A' POST, BELOW PRIMARY JUNCTION FUSE BOX
CA156	LUGGAGE COMPARTMENT, RH SIDE
FH77	LH LOWER 'A' POST, ADJACENT TO THE GENERAL ELECTRONIC CONTROL MODULE (FORWARD OF CA30)

FOR CONTROL MODULE PIN-OUT INFORMATION, UNFOLD PAGE TO LEFT.

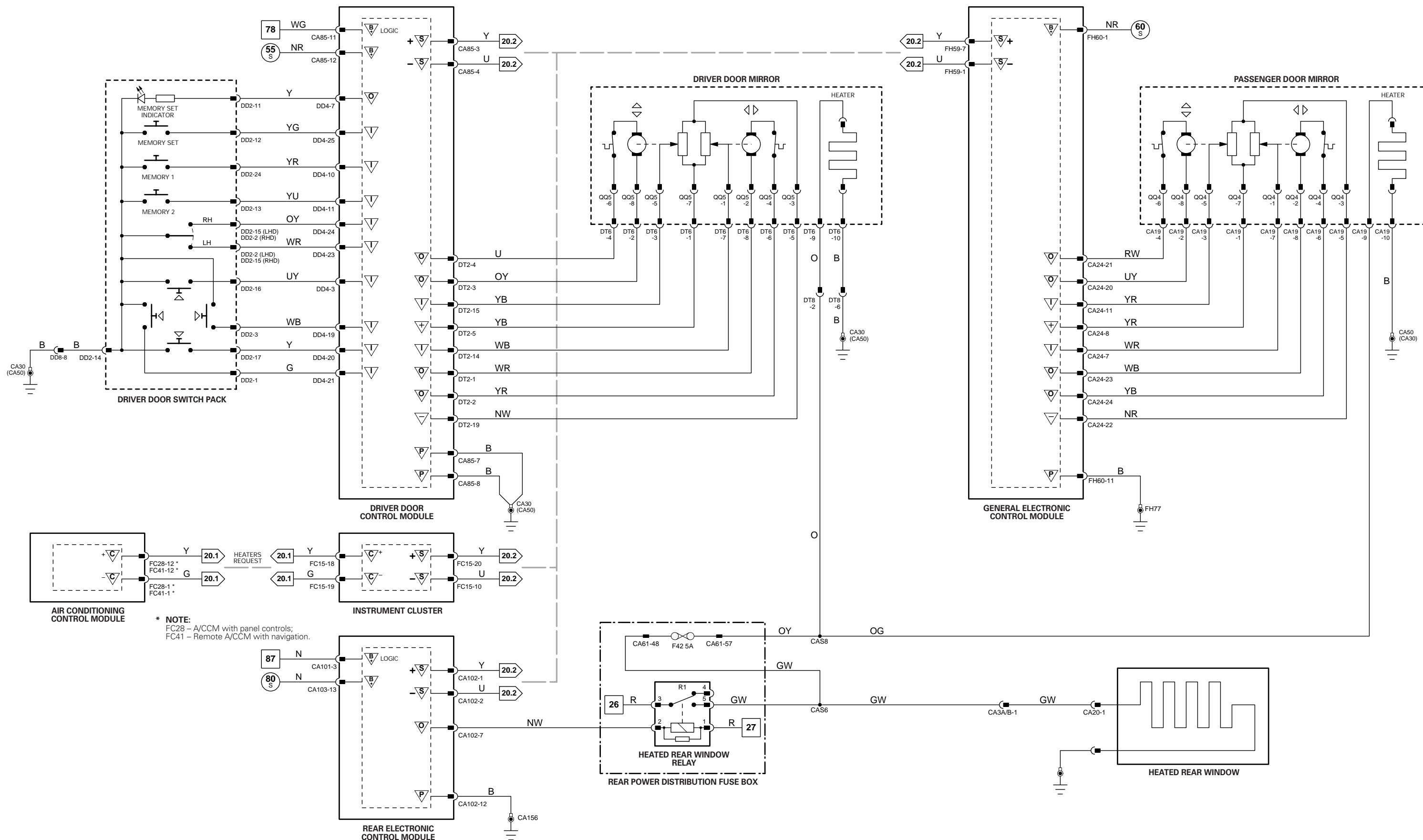

* NOTE:
 FC28 - A/CCM with panel controls;
 FC41 - Remote A/CCM with navigation.

CONTROL MODULE PIN-OUT INFORMATION

Driver Door Control Module

Pin	Description and Characteristic
O CA85-5	MIRROR FOLD FLAT DRIVE: TO ACTIVATE, DDCM SWITCHES CIRCUIT TO B+
O CA85-6	MIRROR FOLD FLAT DRIVE: TO ACTIVATE, DDCM SWITCHES CIRCUIT TO B+
PG CA85-7	POWER GROUND: GROUND
PG CA85-8	POWER GROUND: GROUND
B+ CA85-11	BATTERY POWER SUPPLY: B+
B+ CA85-12	SWITCHED SYSTEM POWER SUPPLY: B+
I DD4-20	MIRROR FOLD FLAT (MIRROR SELECT IN NEUTRAL POSITION): GROUND WHEN ACTIVATED
I DD4-23	LH DOOR MIRROR MOVEMENT SELECT: GROUND WHEN SELECTED
I DD4-24	RH DOOR MIRROR MOVEMENT SELECT: GROUND WHEN SELECTED

Rear Electronic Control Module

Pin	Description and Characteristic
B+ CA101-3	BATTERY POWER SUPPLY: B+
S CA102-1	SCP +
S CA102-2	SCP -
O CA102-7	HEATED REAR WINDOW ACTIVATE: TO ACTIVATE, RECM SWITCHES CIRCUIT TO GROUND
PG CA102-12	POWER GROUND: GROUND
B+ CA103-13	SWITCHED SYSTEM POWER SUPPLY: B+

NOTE: Refer to the Appendix at the rear of this book for Network Messages.

Fig. 10.3

COMPONENTS

Component	Connector(s)	Connector Description	Location
DOOR MIRROR – DRIVER	DT6	22-WAY / BLACK	DRIVER DOOR
DOOR MIRROR – PASSENGER	CA19	22-WAY / BLACK	PASSENGER DOOR
DOOR SWITCH PACK – DRIVER	DD2	26-WAY / YELLOW	DRIVER DOOR ARM REST
DRIVER DOOR CONTROL MODULE	CA85 DD4 DT2	12-WAY / BLACK 26-WAY / NATURAL 20-WAY / BLACK	DRIVER DOOR
ELECTROCHROMIC REAR VIEW MIRROR AND COMPASS	RF5	6-WAY / BLACK	WINDSHIELD, CENTER
REAR ELECTRONIC CONTROL MODULE	CA63 CA100 CA101 CA102 CA103	17-WAY / BLACK 12-WAY / BLACK 20-WAY / BLACK 22-WAY / BLACK 26-WAY / NATURAL	LUGGAGE COMPARTMENT, RH REAR

HARNES IN-LINE CONNECTORS

Connector	Connector Description / Location	Location
DD8	16-WAY / BLUE / CABIN HARNESS TO DRIVER DOOR HARNESS	DRIVER DOOR
DT10	10-WAY / GREY / CABIN HARNESS TO DRIVER DOOR TRIM HARNESS	DRIVER DOOR
RF34	16-WAY / GREEN / CABIN HARNESS TO DOOR HARNESS	'D' POST, UNDER PARCEL SHELF

GROUND S

Ground	Location
CA30	LH LOWER 'A' POST, ADJACENT TO THE GENERAL ELECTRONIC CONTROL MODULE (REARWARD OF FH77)
CA50	RH LOWER 'A' POST, BELOW PRIMARY JUNCTION FUSE BOX
CA116	BEHIND REAR SEAT BACK, RH SIDE
CA156	LUGGAGE COMPARTMENT, RH SIDE

FOR CONTROL MODULE PIN-OUT INFORMATION, UNFOLD PAGE TO LEFT.

The following abbreviations are used to represent values for Control Module Pin-Out data

I	Input	PG	Power Ground	C	CAN Network	D	Serial and Encoded Data
O	Output	SS	Sensor / Signal Supply V	S	SCP Network	V	Voltage (DC)
B+	Battery Voltage	SG	Sensor / Signal Ground	D2	D2B Network	PWM	Pulse Width Modulated

CAUTION: The information on this data page is furnished to aid the user in understanding circuit operation. THIS INFORMATION SHOULD BE USED FOR REFERENCE ONLY.

NOTE: The values listed are approximately those that can be expected at the control module connector pins with all circuit connections made and all components connected and fitted.

Refer to the front of this book for detailed information and illustrations regarding the location and identification of harnesses, relays, fuses, grounds, control modules and control module pins.

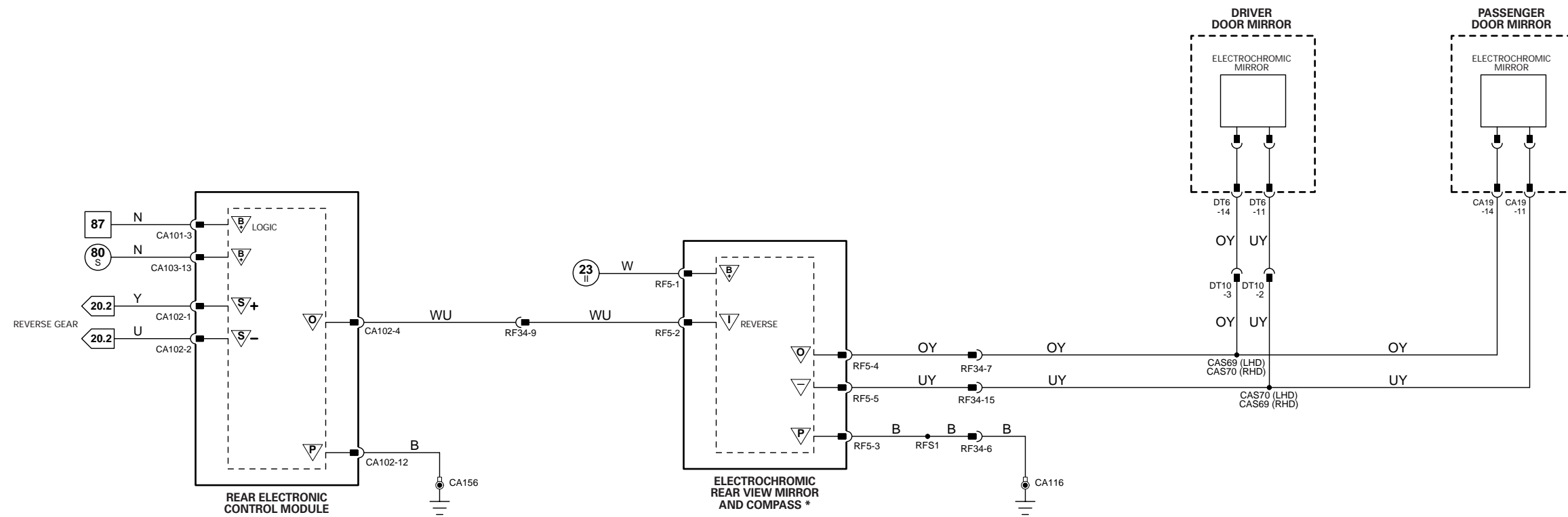

* NOTE: Includes compass, when fitted.

ELECTROCHROMIC REAR VIEW MIRRORS

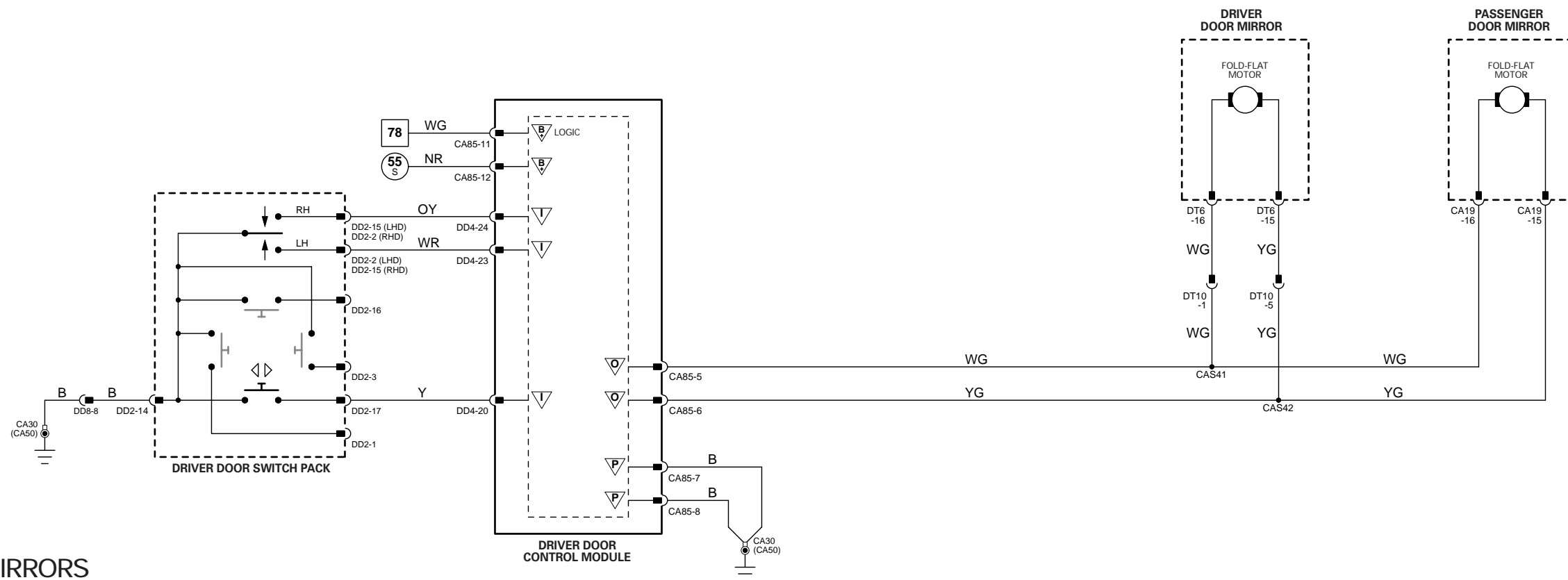

FOLD-BACK MIRRORS

CONTROL MODULE PIN-OUT INFORMATION

Driver Door Control Module

Pin	Description and Characteristic
S CA85-3	SCP +
S CA85-4	SCP -
PG CA85-8	POWER GROUND: GROUND
B+ CA85-11	BATTERY POWER SUPPLY: B+
O DD4-7	MEMORY SET INDICATOR: TO ACTIVATE, DDCM SWITCHES CIRCUIT TO B+
I DD4-10	MEMORY 1: GROUND WHEN SELECTED
I DD4-11	MEMORY 2: GROUND WHEN SELECTED
I DD4-25	MEMORY SET: GROUND WHEN SELECTED

Driver Seat Control Module

Pin	Description and Characteristic
I DM33-7	SEAT CUSHION FRONT POSITION SENSOR SIGNAL: 5 V PULSED SIGNAL
I DM33-8	SEAT HEIGHT POSITION SENSOR SIGNAL: 5 V PULSED SIGNAL
I DM33-9	HEADREST POSITION SENSOR SIGNAL: 5 V PULSED SIGNAL
I DM33-10	SEAT BACK RECLINE POSITION SENSOR SIGNAL: 5 V PULSED SIGNAL
SG DM33-11	SIGNAL GROUND: GROUND
B+ DM33-13	BATTERY POWER SUPPLY: LOGIC: B+
I DM33-22	SEAT POSITION SENSOR SIGNAL: 5 V PULSED SIGNAL
SG DM33-25	SIGNAL GROUND: GROUND
SG DM33-26	LOGIC GROUND: GROUND
S DM34-1	SCP +
I DM34-4	SEAT CUSHION FRONT RAISE REQUEST: ACTIVE = B+
I DM34-5	SEAT CUSHION FRONT LOWER REQUEST: ACTIVE = B+
I DM34-10	SEAT BACK RECLINE REARWARD REQUEST: ACTIVE = B+
I DM34-11	SEAT BACK RECLINE FORWARD REQUEST: ACTIVE = B+
S DM34-12	SCP -
I DM34-17	SEAT RAISE REQUEST: ACTIVE = B+
I DM34-18	SEAT LOWER REQUEST: ACTIVE = B+
I DM34-19	SEAT FORWARD REQUEST: ACTIVE = B+
I DM34-20	SEAT REARWARD REQUEST: ACTIVE = B+
O DM35-1	SEAT HEIGHT MOTOR DRIVE - RAISE: TO ACTIVATE, DSCM SWITCHES CIRCUIT TO B+
O DM35-2	SEAT HEIGHT MOTOR DRIVE - LOWER: TO ACTIVATE, DSCM SWITCHES CIRCUIT TO B+
PG DM35-5	POWER GROUND: GROUND
B+ DM35-6	BATTERY POWER SUPPLY: B+
O DM36-1	SEAT POSITION MOTOR DRIVE - FORWARD: TO ACTIVATE, DSCM SWITCHES CIRCUIT TO B+
O DM36-2	SEAT POSITION MOTOR DRIVE - REARWARD: TO ACTIVATE, DSCM SWITCHES CIRCUIT TO B+
O DM37-3	SEAT BACK RECLINE MOTOR DRIVE - REARWARD: TO ACTIVATE, DSCM SWITCHES CIRCUIT TO B+
O DM37-4	SEAT BACK RECLINE MOTOR DRIVE - FORWARD: TO ACTIVATE, DSCM SWITCHES CIRCUIT TO B+
PG DM38-1	POWER GROUND: GROUND
B+ DM38-2	BATTERY POWER SUPPLY: B+
O DM38-5	SEAT CUSHION FRONT MOTOR DRIVE - RAISE: TO ACTIVATE, DSCM SWITCHES CIRCUIT TO B+
O DM38-6	SEAT CUSHION FRONT MOTOR DRIVE - LOWER: TO ACTIVATE, DSCM SWITCHES CIRCUIT TO B+

NOTE: Refer to the Appendix at the rear of this book for Network Messages.

The following abbreviations are used to represent values for Control Module Pin-Out data

I	Input	PG	Power Ground	C	CAN Network	D	Serial and Encoded Data
O	Output	SS	Sensor / Signal Supply V	S	SCP Network	V	Voltage (DC)
B+	Battery Voltage	SG	Sensor / Signal Ground	D2	D2B Network	PWM	Pulse Width Modulated

CAUTION: The information on this data page is furnished to aid the user in understanding circuit operation. THIS INFORMATION SHOULD BE USED FOR REFERENCE ONLY.

NOTE: The values listed are approximately those that can be expected at the control module connector pins with all circuit connections made and all components connected and fitted.

Fig. 11.1

COMPONENTS

Component	Connector(s)	Connector Description	Location
DOOR SWITCH PACK - DRIVER	DD2	26-WAY / YELLOW	DRIVER DOOR ARM REST
DRIVER DOOR CONTROL MODULE	CA85	12-WAY / BLACK	DRIVER DOOR
	DD4	26-WAY / NATURAL	
	DT2	20-WAY / BLACK	
DRIVER SEAT CONTROL MODULE	DM33	26-WAY / BLACK	UNDER DRIVER SEAT
	DM34	22-WAY / BLACK	
	DM35	6-WAY / BLACK	
	DM36	4-WAY / BLACK	
	DM37	4-WAY / BLACK	
	DM38	6-WAY / BLACK	
LUMBAR PUMP - DRIVER	DL4	3-WAY / BLACK	LOWER SEAT BACK
SEAT MOTORS AND POSITION SENSORS - DRIVER	DM25	4-WAY / BLACK	DRIVER SEAT
	DM26	4-WAY / BLACK	
	DM27	4-WAY / BLACK	
	DM28	4-WAY / BLACK	
	DM29	4-WAY / BLACK	
	DM31	4-WAY / BLACK	
SEAT SWITCH PACK - DRIVER	DM7	12-WAY / BLACK	DRIVER SEAT
	DM43	14-WAY / BLACK	

HARNESS IN-LINE CONNECTORS

Connector	Connector Description / Location	Location
DD8	16-WAY / BLUE / CABIN HARNESS TO DRIVER DOOR HARNESS	DRIVER DOOR
DL2	6-WAY / BLACK / DRIVER SEAT IN-LINE CONNECTOR	DRIVER SEAT BACK REST
DM22	4-WAY / GREY / CABIN HARNESS TO DRIVER SEAT HARNESS	UNDER DRIVER SEAT
DM23	20-WAY / BLACK / CABIN HARNESS TO DRIVER SEAT HARNESS	UNDER DRIVER SEAT

GROUND

Ground	Location
CA30	LH LOWER 'A' POST, ADJACENT TO THE GENERAL ELECTRONIC CONTROL MODULE (REARWARD OF FH77)
CA50	RH LOWER 'A' POST, BELOW PRIMARY JUNCTION FUSE BOX
CA141	UNDER LH FRONT SEAT
CA154	UNDER RH FRONT SEAT

FOR CONTROL MODULE PIN-OUT INFORMATION, UNFOLD PAGE TO LEFT.

Refer to the front of this book for detailed information and illustrations regarding the location and identification of harnesses, relays, fuses, grounds, control modules and control module pins.

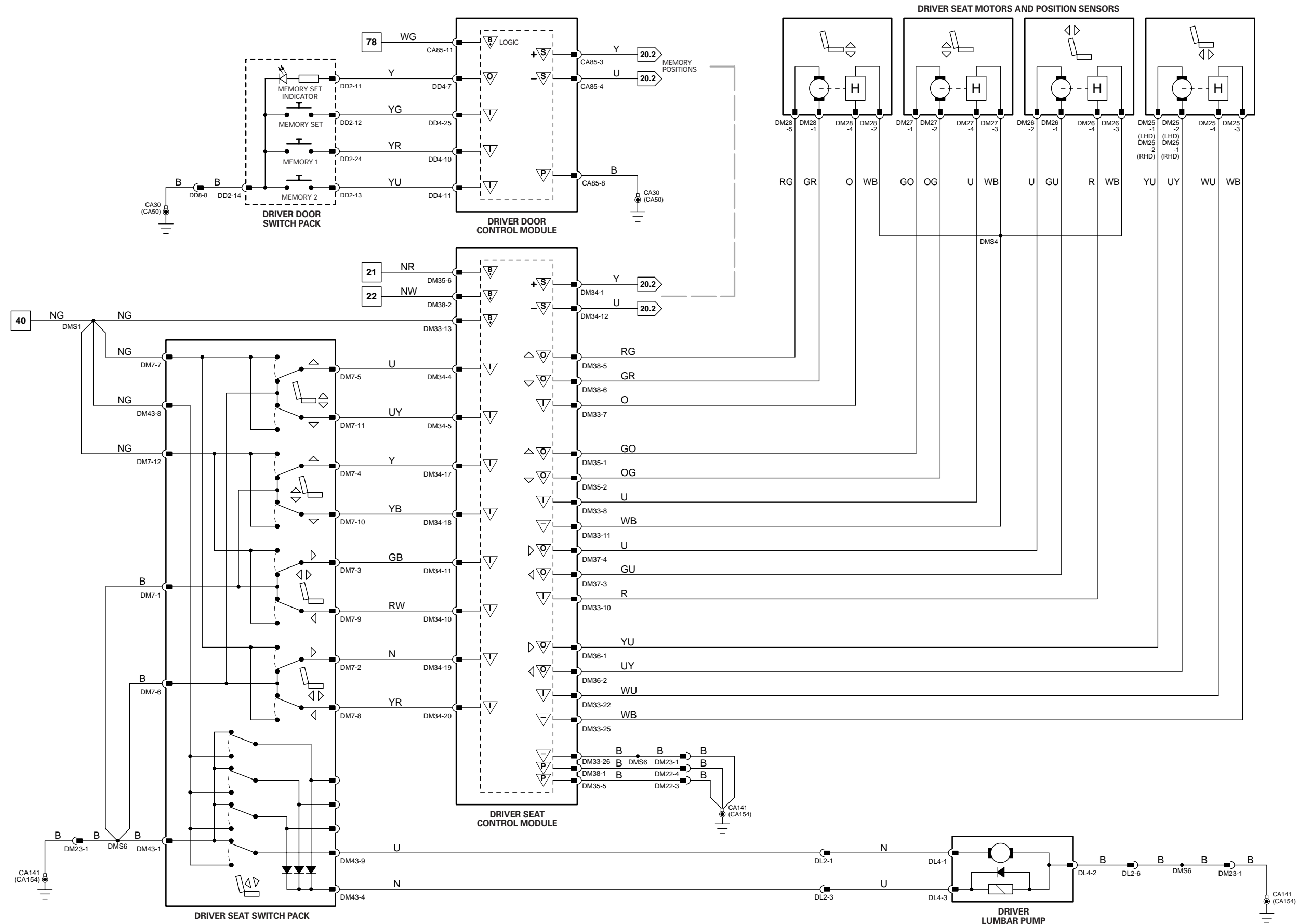

CONTROL MODULE PIN-OUT INFORMATION

Driver Seat Control Module

Pin	Description and Characteristic
I	DM33-7 SEAT CUSHION FRONT POSITION SENSOR SIGNAL: 5 V PULSED SIGNAL
I	DM33-8 SEAT HEIGHT POSITION SENSOR SIGNAL: 5 V PULSED SIGNAL
I	DM33-9 HEADREST POSITION SENSOR SIGNAL: 5 V PULSED SIGNAL
I	DM33-10 SEAT BACK RECLINE POSITION SENSOR SIGNAL: 5 V PULSED SIGNAL
SG	DM33-11 SIGNAL GROUND: GROUND
SG	DM33-12 SIGNAL GROUND: GROUND
B+	DM33-13 BATTERY POWER SUPPLY: LOGIC: B+
I	DM33-22 SEAT POSITION SENSOR SIGNAL: 5 V PULSED SIGNAL
I	DM33-23 SEAT CUSHION EXTEND POSITION SENSOR SIGNAL: 5 V PULSED SIGNAL
SG	DM33-25 SIGNAL GROUND: GROUND
SG	DM33-26 LOGIC GROUND: GROUND
S	DM34-1 SCP +
I	DM34-4 SEAT CUSHION FRONT RAISE REQUEST: ACTIVE = B+
I	DM34-5 SEAT CUSHION FRONT LOWER REQUEST: ACTIVE = B+
I	DM34-10 SEAT BACK RECLINE REARWARD REQUEST: ACTIVE = B+
I	DM34-11 SEAT BACK RECLINE FORWARD REQUEST: ACTIVE = B+
S	DM34-12 SCP -
I	DM34-15 HEAD REST RAISE REQUEST: ACTIVE = B+
I	DM34-16 HEADREST LOWER REQUEST: ACTIVE = B+
I	DM34-17 SEAT RAISE REQUEST: ACTIVE = B+
I	DM34-18 SEAT LOWER REQUEST: ACTIVE = B+
I	DM34-19 SEAT FORWARD REQUEST: ACTIVE = B+
I	DM34-20 SEAT REARWARD REQUEST: ACTIVE = B+
I	DM34-21 SEAT CUSHION EXTEND REARWARD REQUEST: ACTIVE = B+
I	DM34-22 SEAT CUSHION EXTEND FORWARD REQUEST: ACTIVE = B+
O	DM35-1 SEAT HEIGHT MOTOR DRIVE - RAISE: TO ACTIVATE, DSCM SWITCHES CIRCUIT TO B+
O	DM35-2 SEAT HEIGHT MOTOR DRIVE - LOWER: TO ACTIVATE, DSCM SWITCHES CIRCUIT TO B+
PG	DM35-5 POWER GROUND: GROUND
B+	DM35-6 BATTERY POWER SUPPLY: B+
O	DM36-1 SEAT POSITION MOTOR DRIVE - FORWARD: TO ACTIVATE, DSCM SWITCHES CIRCUIT TO B+
O	DM36-2 SEAT POSITION MOTOR DRIVE - REARWARD: TO ACTIVATE, DSCM SWITCHES CIRCUIT TO B+
O	DM36-3 SEAT CUSHION EXTEND MOTOR DRIVE - REARWARD: TO ACTIVATE, DSCM SWITCHES CIRCUIT TO B+
O	DM36-4 SEAT CUSHION EXTEND MOTOR DRIVE - FORWARD: TO ACTIVATE, DSCM SWITCHES CIRCUIT TO B+
O	DM37-3 SEAT BACK RECLINE MOTOR DRIVE - REARWARD: TO ACTIVATE, DSCM SWITCHES CIRCUIT TO B+
O	DM37-4 SEAT BACK RECLINE MOTOR DRIVE - FORWARD: TO ACTIVATE, DSCM SWITCHES CIRCUIT TO B+
PG	DM38-1 POWER GROUND: GROUND
B+	DM38-2 BATTERY POWER SUPPLY: B+
O	DM38-3 HEADREST POSITION MOTOR DRIVE - RAISE: TO ACTIVATE, DSCM SWITCHES CIRCUIT TO B+
O	DM38-4 HEADREST POSITION MOTOR DRIVE - LOWER: TO ACTIVATE, DSCM SWITCHES CIRCUIT TO B+
O	DM38-5 SEAT CUSHION FRONT MOTOR DRIVE - RAISE: TO ACTIVATE, DSCM SWITCHES CIRCUIT TO B+
O	DM38-6 SEAT CUSHION FRONT MOTOR DRIVE - LOWER: TO ACTIVATE, DSCM SWITCHES CIRCUIT TO B+

NOTE: Refer to the Appendix at the rear of this book for Network Messages.

The following abbreviations are used to represent values for Control Module Pin-Out data

I	Input	PG	Power Ground	C	CAN Network	D	Serial and Encoded Data
O	Output	SS	Sensor / Signal Supply V	S	SCP Network	V	Voltage (DC)
B+	Battery Voltage	SG	Sensor / Signal Ground	D2	D2B Network	PWM	Pulse Width Modulated

CAUTION: The information on this data page is furnished to aid the user in understanding circuit operation. THIS INFORMATION SHOULD BE USED FOR REFERENCE ONLY.

NOTE: The values listed are approximately those that can be expected at the control module connector pins with all circuit connections made and all components connected and fitted.

Fig. 11.2

COMPONENTS

Component	Connector(s)	Connector Description	Location
DRIVER SEAT CONTROL MODULE	DM33 DM34 DM35 DM36 DM37 DM38	26-WAY / BLACK 22-WAY / BLACK 6-WAY / BLACK 4-WAY / BLACK 4-WAY / BLACK 6-WAY / BLACK	UNDER DRIVER SEAT
LUMBAR PUMP - DRIVER (16-WAY)	DL3	2-WAY / BLACK	LOWER SEAT BACK
LUMBAR SOLENOIDS - DRIVER	DL1	6-WAY / BLACK	UPPER SEAT BACK
SEAT MOTORS AND POSITION SENSORS - DRIVER	DM25 DM26 DM27 DM28 DM29 DM31	4-WAY / BLACK 4-WAY / BLACK 4-WAY / BLACK 4-WAY / BLACK 4-WAY / BLACK 4-WAY / BLACK	DRIVER SEAT
SEAT SWITCH PACK - DRIVER	DM7 DM43	12-WAY / BLACK 14-WAY / BLACK	DRIVER SEAT

HARNES IN-LINE CONNECTORS

Connector	Connector Description / Location	Location
DL2	6-WAY / BLACK / DRIVER SEAT IN-LINE CONNECTOR	DRIVER SEAT BACK REST
DM22	4-WAY / GREY / CABIN HARNESS TO DRIVER SEAT HARNESS	UNDER DRIVER SEAT
DM23	20-WAY / BLACK / CABIN HARNESS TO DRIVER SEAT HARNESS	UNDER DRIVER SEAT

GROUNDS

Ground	Location
CA141	UNDER LH FRONT SEAT
CA154	UNDER RH FRONT SEAT

FOR CONTROL MODULE PIN-OUT INFORMATION, UNFOLD PAGE TO LEFT.

Refer to the front of this book for detailed information and illustrations regarding the location and identification of harnesses, relays, fuses, grounds, control modules and control module pins.

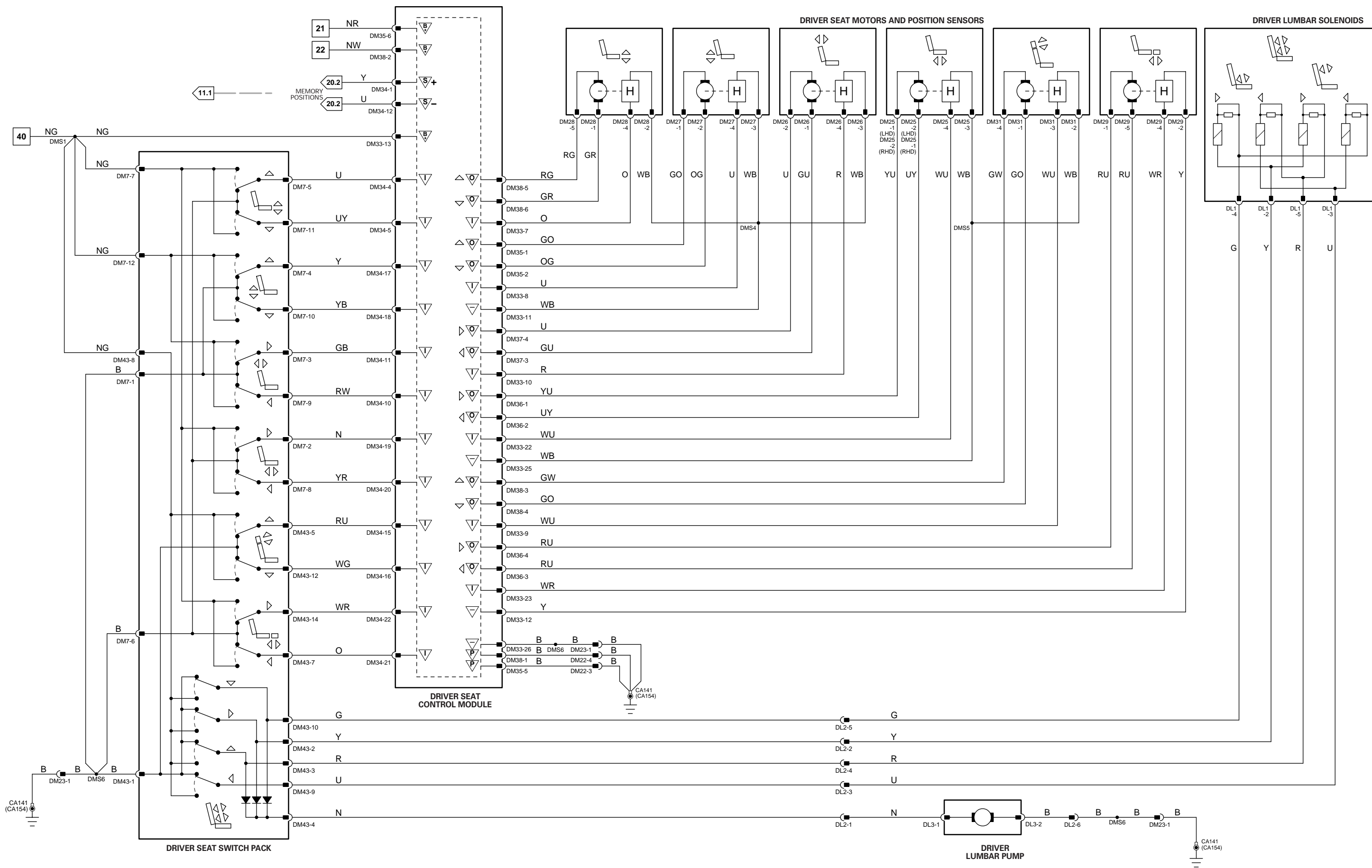

Fig. 11.3**COMPONENTS**

Component	Connector(s)	Connector Description	Location
LUMBAR PUMP – DRIVER	DL4	3-WAY / BLACK	LOWER SEAT BACK
SEAT MOTORS AND POSITION SENSORS – DRIVER	DM25 DM26 DM27 DM28	4-WAY / BLACK 4-WAY / BLACK 4-WAY / BLACK 4-WAY / BLACK	DRIVER SEAT
SEAT SWITCH PACK – DRIVER	DM7 DM43	12-WAY / BLACK 14-WAY / BLACK	DRIVER SEAT

HARNESS IN-LINE CONNECTORS

Connector	Connector Description / Location	Location
DL2	6-WAY / BLACK / DRIVER SEAT IN-LINE CONNECTOR	DRIVER SEAT BACK REST
DM22	4-WAY / GREY / CABIN HARNESS TO DRIVER SEAT HARNESS	UNDER DRIVER SEAT
DM23	20-WAY / BLACK / CABIN HARNESS TO DRIVER SEAT HARNESS	UNDER DRIVER SEAT

GROUNDS

Ground	Location
CA141	UNDER LH FRONT SEAT
CA154	UNDER RH FRONT SEAT

Refer to the front of this book for detailed information and illustrations regarding the location and identification of harnesses, relays, fuses, grounds, control modules and control module pins.

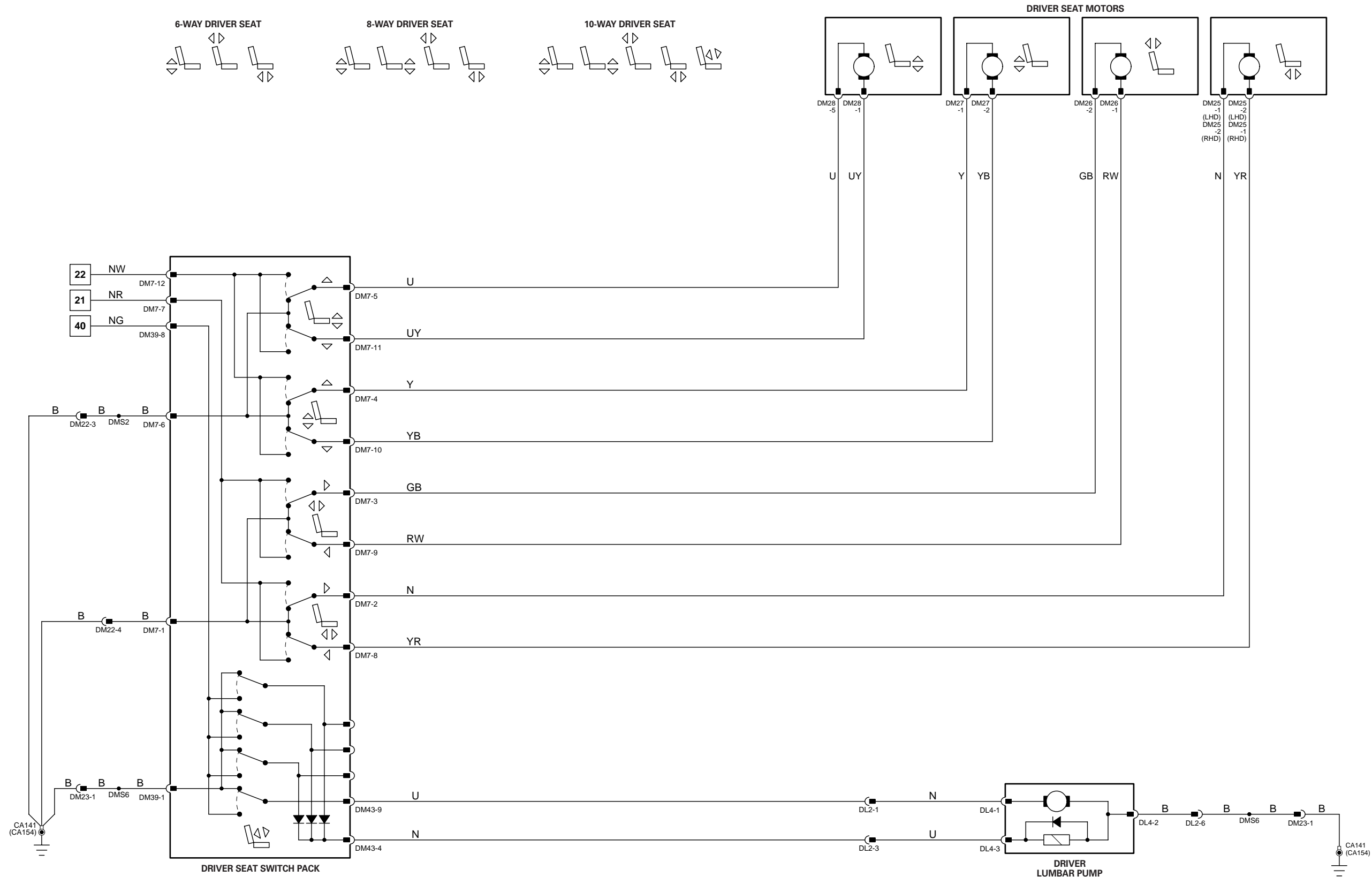

Fig. 11.4**COMPONENTS**

Component	Connector(s)	Connector Description	Location
LUMBAR PUMP - PASSENGER	PL4	3-WAY / BLACK	LOWER SEAT BACK
SEAT MOTORS - PASSENGER	PN26	4-WAY / BLACK	PASSENGER SEAT
	PN27	4-WAY / BLACK	
	PN28	4-WAY / BLACK	
	PN30	4-WAY / BLACK	
SEAT SWITCH PACK - PASSENGER	PN4	12-WAY / BLACK	PASSENGER SEAT
	PN39	14-WAY / BLACK	

HARNESS IN-LINE CONNECTORS

Connector	Connector Description / Location	Location
PL2	6-WAY / BLACK / PASSENGER SEAT IN-LINE CONNECTOR	PASSENGER SEAT BACK REST
PN23	4-WAY / GREY / CABIN HARNESS TO PASSENGER SEAT HARNESS	UNDER PASSENGER SEAT
PN24	20-WAY / BLACK / CABIN HARNESS TO PASSENGER SEAT HARNESS	UNDER PASSENGER SEAT

GROUNDS

Ground	Location
CA141	UNDER LH FRONT SEAT
CA154	UNDER RH FRONT SEAT

Refer to the front of this book for detailed information and illustrations regarding the location and identification of harnesses, relays, fuses, grounds, control modules and control module pins.

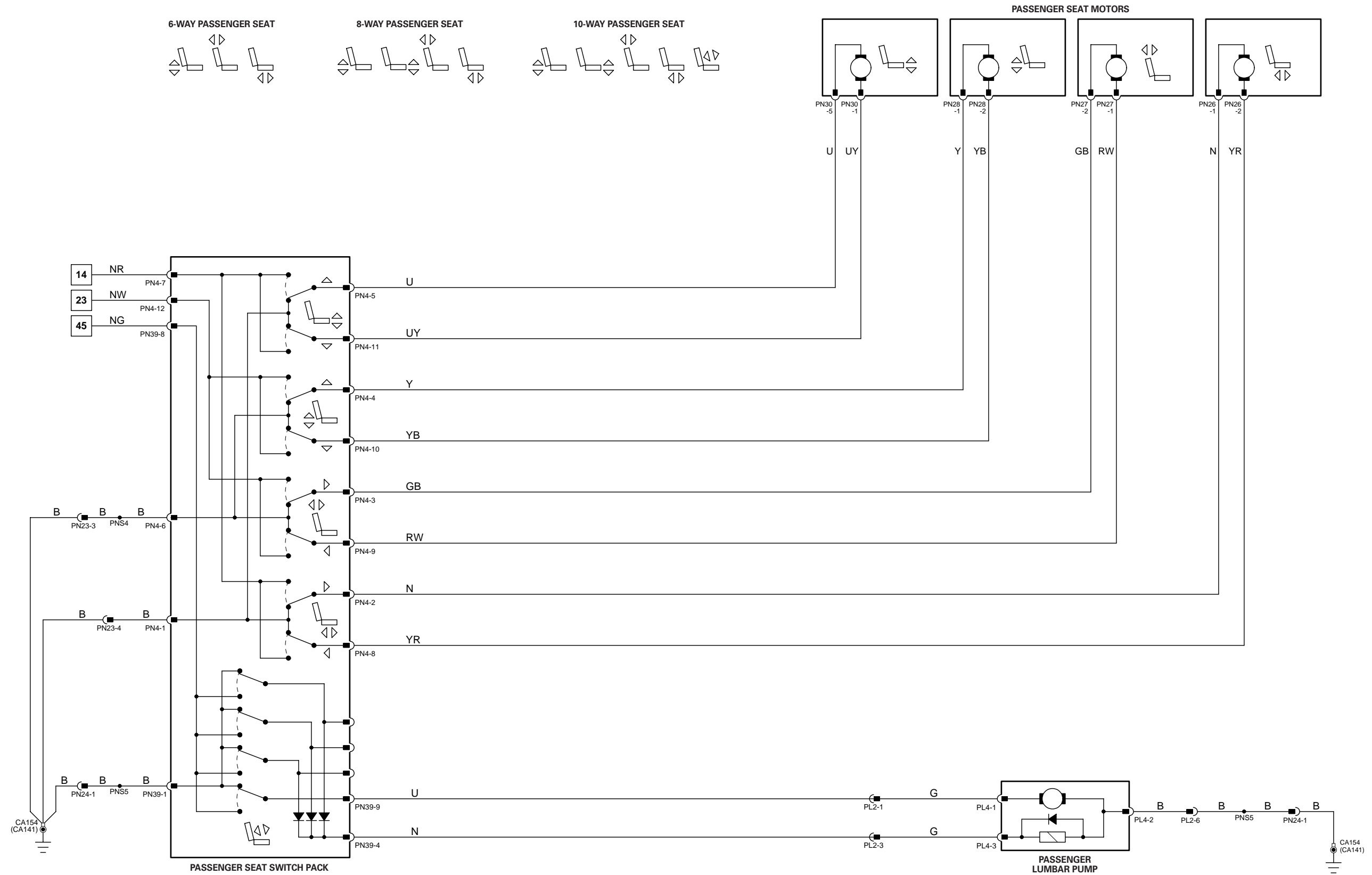

Fig. 11.5**COMPONENTS**

Component	Connector(s)	Connector Description	Location
LUMBAR PUMP - PASSENGER (16-WAY)	PL3	2-WAY / BLACK	LOWER SEAT BACK
LUMBAR SOLENOIDS - PASSENGER	PL1	6-WAY / BLACK	UPPER SEAT BACK
SEAT MOTORS AND POSITION SENSORS - PASSENGER	PN26	4-WAY / BLACK	PASSENGER SEAT
	PN27	4-WAY / BLACK	
	PN28	4-WAY / BLACK	
	PN30	4-WAY / BLACK	
	PN31	4-WAY / BLACK	
	PN33	4-WAY / BLACK	
	SEAT SWITCH PACK - PASSENGER	PN4	
	PN39	14-WAY / BLACK	

HARNESS IN-LINE CONNECTORS

Connector	Connector Description / Location	Location
PL2	6-WAY / BLACK / PASSENGER SEAT IN-LINE CONNECTOR	PASSENGER SEAT BACK REST
PN23	4-WAY / GREY / CABIN HARNESS TO PASSENGER SEAT HARNESS	UNDER PASSENGER SEAT
PN24	20-WAY / BLACK / CABIN HARNESS TO PASSENGER SEAT HARNESS	UNDER PASSENGER SEAT

GROUNDS

Ground	Location
CA141	UNDER LH FRONT SEAT
CA154	UNDER RH FRONT SEAT

Refer to the front of this book for detailed information and illustrations regarding the location and identification of harnesses, relays, fuses, grounds, control modules and control module pins.

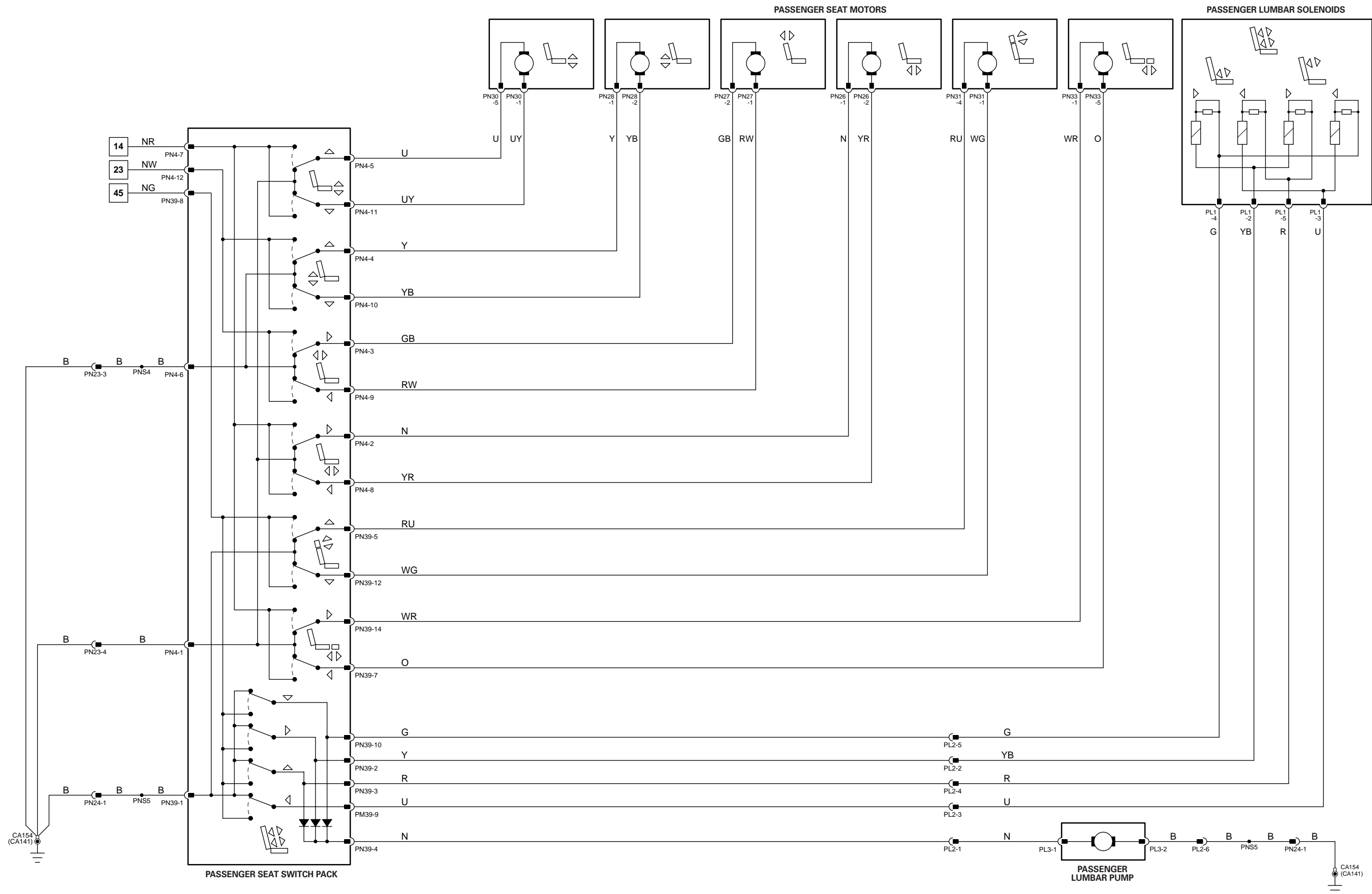

Fig. 01.1	Fig. 01.2	Fig. 01.3	Fig. 01.4	Fig. 01.5	Fig. 01.6	Fig. 01.7	Input	Battery Voltage	Sensor/Signal Supply V	CAN	D2B Network
							Output	Power Ground	Sensor/Signal Ground	SCP	Serial and Encoded Data

VARIANT: 16-Way Passenger Seat Vehicles
 VIN RANGE: All
 DATE OF ISSUE: June 2002

Fig. 11.6**COMPONENTS**

Component	Connector(s)	Connector Description	Location
CENTER CONSOLE SWITCH PACK	FC113 FC119	8-WAY / BLACK 8-WAY / BLACK	CENTER CONSOLE
SEAT BACK HEATER – DRIVER	DB7	2-WAY / BLACK	DRIVER SEAT BACK
SEAT BACK HEATER – PASSENGER	PB7	2-WAY / BLACK	PASSENGER SEAT BACK
SEAT CUSHION HEATER – DRIVER	DM16	4-WAY / BLACK	DRIVER SEAT CUSHION
SEAT CUSHION HEATER – PASSENGER	PN12	4-WAY / BLACK	PASSENGER SEAT CUSHION
SEAT HEATER MODULE – DRIVER	DM15	12-WAY / GREY	UNDER DRIVER SEAT
SEAT HEATER MODULE – PASSENGER	PN7	12-WAY / GREY	UNDER PASSENGER SEAT

HARNESS IN-LINE CONNECTORS

Connector	Connector Description / Location	Location
DM23	20-WAY / BLACK / CABIN HARNESS TO DRIVER SEAT HARNESS	UNDER DRIVER SEAT
FC17	16-WAY / BLUE / CABIN HARNESS TO FASCIA HARNESS	BEHIND INSTRUMENT PANEL, PASSENGER SIDE
FC26	16-WAY / BLUE / CABIN HARNESS TO FASCIA HARNESS	BEHIND INSTRUMENT PANEL, DRIVER SIDE
PN24	20-WAY / BLACK / CABIN HARNESS TO PASSENGER SEAT HARNESS	UNDER PASSENGER SEAT

GROUNDS

Ground	Location
CA141	UNDER LH FRONT SEAT
CA154	UNDER RH FRONT SEAT
FC38	UNDER CENTER OF INSTRUMENT PANEL, ON TRANSMISSION TUNNEL

Refer to the front of this book for detailed information and illustrations regarding the location and identification of harnesses, relays, fuses, grounds, control modules and control module pins.

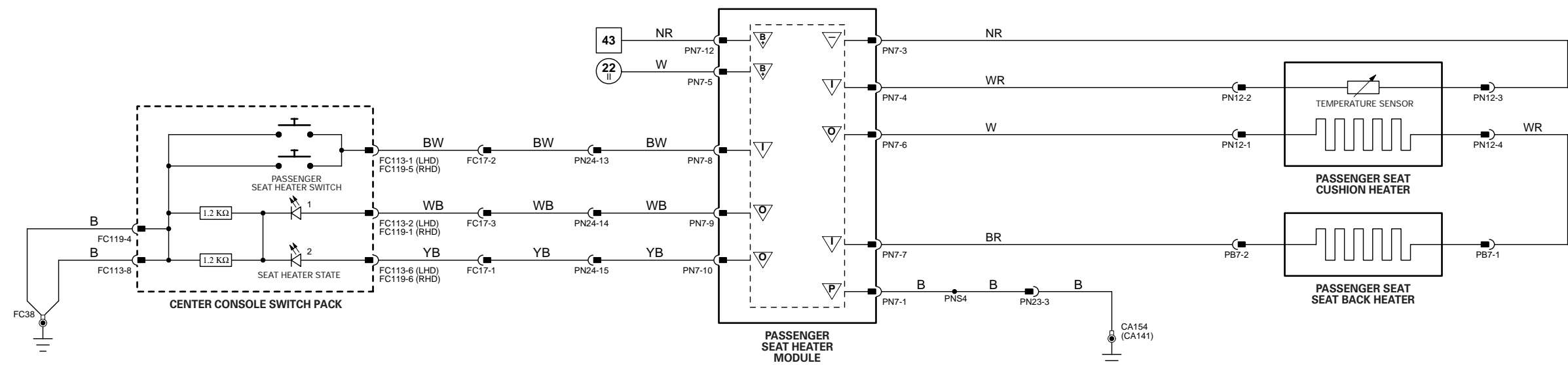
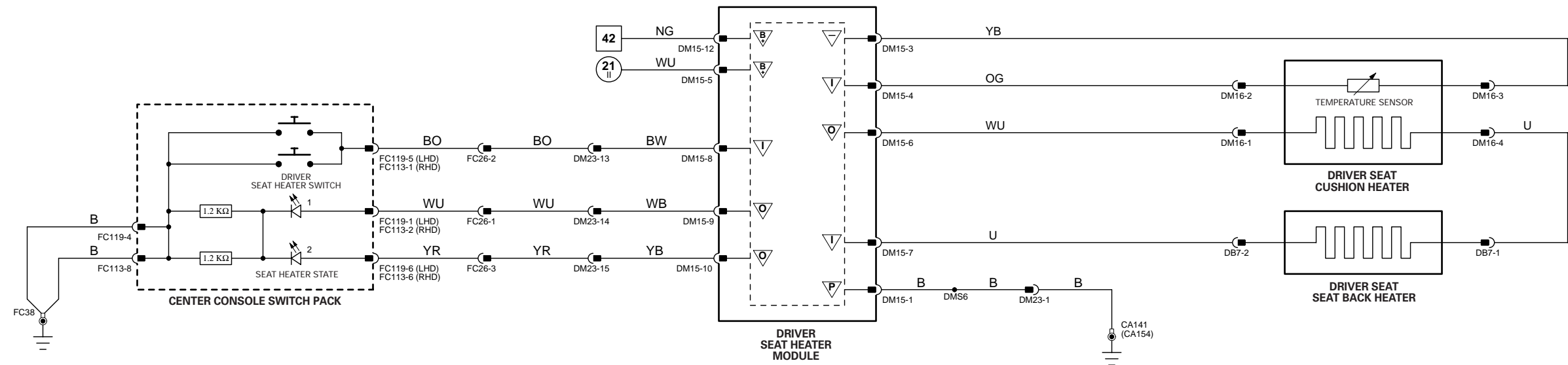

CONTROL MODULE PIN-OUT INFORMATION

Driver Door Control Module

Pin	Description and Characteristic
I CA85-2	LOCK / UNLOCK STATUS SWITCH (NORMALLY OPEN): OPEN CIRCUIT / GROUND
S CA85-3	SCP +
S CA85-4	SCP -
PG CA85-8	POWER GROUND: GROUND
PG CA85-9	REMOTE KEYLESS ENTRY MODULE GROUND: GROUND
I CA85-10	DOUBLE LOCK STATUS SWITCH (NORMALLY OPEN): OPEN CIRCUIT / GROUND
B+ CA85-11	BATTERY POWER SUPPLY: B+
B+ CA85-12	SWITCHED SYSTEM POWER SUPPLY: B+
O DT2-6	REMOTE KEYLESS ENTRY MODULE POWER SUPPLY: B+
O DT2-8	LOCK DRIVE: TO ACTIVATE, DDCM SWITCHES CIRCUIT TO B+
O DT2-9	UNLOCK DRIVE: TO ACTIVATE, DDCM SWITCHES CIRCUIT TO B+
O DT2-10	DOUBLE LOCK DRIVE: TO ACTIVATE, DDCM SWITCHES CIRCUIT TO B+
D DT2-13	REMOTE KEYLESS ENTRY MODULE SIGNAL: ENCODED COMMUNICATIONS
I DT2-16	DRIVER DOOR ALARM SET / LOCK SWITCH (NORMALLY OPEN): OPEN CIRCUIT / GROUND
I DT2-17	DRIVER DOOR ALARM RESET / UNLOCK SWITCH (NORMALLY OPEN): OPEN CIRCUIT / GROUND
D DT2-18	REMOTE KEYLESS ENTRY MODULE SIGNAL: ENCODED COMMUNICATIONS

General Electronic Control Module

Pin	Description and Characteristic
I CA24-4	NON-VALET VEHICLES - EXTERNAL TRUNK RELEASE SWITCH (NORMALLY OPEN): OPEN CIRCUIT / GROUND VALET VEHICLES - EXTERNAL TRUNK RELEASE SWITCH (NORMALLY OPEN) / VALET SWITCH (NORMALLY CLOSED): OPEN CIRCUIT / GROUND
I CA24-15	PASSENGER DOOR AJAR SWITCH (NORMALLY OPEN): OPEN CIRCUIT / GROUND
I CA31-8	DRIVER DOOR AJAR SWITCH (NORMALLY OPEN): OPEN CIRCUIT / GROUND
S FH59-1	SCP -
B+ FH59-6	BATTERY POWER SUPPLY (LOGIC): B+
S FH59-7	SCP +
B+ FH60-1	SWITCHED SYSTEM POWER SUPPLY: B+
PG FH60-11	POWER GROUND: GROUND

Rear Electronic Control Module

Pin	Description and Characteristic
I CA100-9	GLOBAL CLOSE SWITCH (NORMALLY OPEN): OPEN CIRCUIT / GROUND
B+ CA101-3	BATTERY POWER SUPPLY: B+
I CA101-17	LHD - RH REAR DOOR AJAR SWITCH (NORMALLY OPEN): OPEN CIRCUIT / GROUND RHD - LH REAR DOOR AJAR SWITCH (NORMALLY OPEN): OPEN CIRCUIT / GROUND
I CA101-18	DOUBLE LOCK STATUS SWITCH (NORMALLY OPEN): OPEN CIRCUIT / GROUND
I CA101-19	LOCK / UNLOCK STATUS SWITCH (NORMALLY OPEN): OPEN CIRCUIT / GROUND
S CA102-1	SCP +
S CA102-2	SCP -
PG CA102-12	POWER GROUND: GROUND
I CA102-14	TRUNK AJAR SWITCH (NORMALLY OPEN): OPEN CIRCUIT / GROUND
O CA103-4	LOCK DRIVE: TO ACTIVATE, DDCM SWITCHES CIRCUIT TO B+
O CA103-5	LOCK DRIVE: TO ACTIVATE, DDCM SWITCHES CIRCUIT TO B+
O CA103-6	UNLOCK DRIVE: TO ACTIVATE, DDCM SWITCHES CIRCUIT TO B+
O CA103-7	UNLOCK DRIVE: TO ACTIVATE, DDCM SWITCHES CIRCUIT TO B+
O CA103-8	DOUBLE LOCK DRIVE: TO ACTIVATE, DDCM SWITCHES CIRCUIT TO B+
O CA103-9	DOUBLE LOCK DRIVE: TO ACTIVATE, DDCM SWITCHES CIRCUIT TO B+
O CA103-10	TRUNK RELEASE DRIVE: TO ACTIVATE, DDCM SWITCHES CIRCUIT TO B+
B+ CA103-13	SWITCHED SYSTEM POWER SUPPLY: B+
I CA103-16	LHD - LH REAR DOOR AJAR SWITCH (NORMALLY OPEN): OPEN CIRCUIT / GROUND RHD - RH REAR DOOR AJAR SWITCH (NORMALLY OPEN): OPEN CIRCUIT / GROUND

NOTE: Refer to the Appendix at the rear of this book for Network Messages.

The following abbreviations are used to represent values for Control Module Pin-Out data

I	Input	PG	Power Ground	C	CAN Network	D	Serial and Encoded Data
O	Output	SS	Sensor / Signal Supply V	S	SCP Network	V	Voltage (DC)
B+	Battery Voltage	SG	Sensor / Signal Ground	D2	D2B Network	PWM	Pulse Width Modulated

CAUTION: The information on this data page is furnished to aid the user in understanding circuit operation. THIS INFORMATION SHOULD BE USED FOR REFERENCE ONLY.

NOTE: The values listed are approximately those that can be expected at the control module connector pins with all circuit connections made and all components connected and fitted.

Fig. 12.1

COMPONENTS

Component	Connector(s)	Connector Description	Location
CENTER CONSOLE SWITCH PACK	FC113 FC119	8-WAY / BLACK 8-WAY / BLACK	CENTER CONSOLE
DOOR LATCH ASSEMBLY - DRIVER	DT5	10-WAY / BLACK	DRIVER DOOR
DOOR LATCH ASSEMBLY - RH REAR	CA90	10-WAY / BLACK	RH REAR DOOR
DOOR LATCH ASSEMBLY - LH REAR	CA81	10-WAY / BLACK	LH REAR DOOR
DOOR LATCH ASSEMBLY - PASSENGER	PT3	10-WAY / BLACK	PASSENGER DOOR
DRIVER DOOR CONTROL MODULE	CA85 DD4 DT2	12-WAY / BLACK 26-WAY / NATURAL 20-WAY / BLACK	DRIVER DOOR
EXTERNAL TRUNK RELEASE SWITCH	CA97	2-WAY / BLACK	LUGGAGE COMPARTMENT LID
FUEL FLAP AND TRUNK RELEASE SWITCH PACK	FC43	10-WAY / GREY	INSTRUMENT PANEL
FUEL FLAP RELAY	—	—	REAR POWER DISTRIBUTION FUSE BOX - R8
FUEL FLAP RELEASE SOLENOID	CA106	2-WAY / GREY	LUGGAGE COMPARTMENT, RH SIDE, FRONT
GENERAL ELECTRONIC CONTROL MODULE	FH9 CA24 CA31 FH59 FH60	22-WAY / BLACK 26-WAY / NATURAL 20-WAY / BLACK 12-WAY / BLACK 17-WAY / BLACK	LH 'A' POST
REAR ELECTRONIC CONTROL MODULE	CA63 CA100 CA101 CA102 CA103	17-WAY / BLACK 12-WAY / BLACK 20-WAY / BLACK 22-WAY / BLACK 26-WAY / NATURAL	LUGGAGE COMPARTMENT, RH REAR
REAR POWER DISTRIBUTION FUSE BOX	—	—	LUGGAGE COMPARTMENT
REMOTE KEYLESS ENTRY MODULE	CA303	4-WAY / BLACK	UNDER CENTER CONSOLE
TRUNK AJAR SWITCH	CA117	2-WAY / BLACK	LUGGAGE COMPARTMENT LID
TRUNK RELEASE SOLENOID	CA105	3-WAY / BLACK	LUGGAGE COMPARTMENT LID
VALET SWITCH	V51	6-WAY / BLACK	GLOVE BOX

HARNESS IN-LINE CONNECTORS

Connector	Connector Description / Location	Location
DT8	14-WAY / GREY / CABIN HARNESS TO DRIVER DOOR TRIM HARNESS	DRIVER DOOR
DT10	10-WAY / GREY / CABIN HARNESS TO DRIVER DOOR TRIM HARNESS	DRIVER DOOR
FC121	4-WAY / GREY / FASCIA HARNESS IN-LINE CONNECTOR	BEHIND GLOVE BOX
FC23	10-WAY / GREY / CABIN HARNESS TO FASCIA HARNESS	BEHIND INSTRUMENT PANEL, LH SIDE
FC33	16-WAY / GREEN / CABIN HARNESS TO FASCIA HARNESS	BEHIND INSTRUMENT PANEL, RH SIDE
FC39	10-WAY / GREY / CABIN HARNESS TO FASCIA HARNESS	BEHIND INSTRUMENT PANEL, RH SIDE
PT1	14-WAY / GREY / CABIN HARNESS TO PASSENGER DOOR TRIM HARNESS	PASSENGER DOOR

GROUNDINGS

Ground	Location
CA30	LH LOWER 'A' POST, ADJACENT TO THE GENERAL ELECTRONIC CONTROL MODULE (REARWARD OF FH77)
CA50	RH LOWER 'A' POST, BELOW PRIMARY JUNCTION FUSE BOX
CA141	UNDER LH FRONT SEAT
CA154	UNDER RH FRONT SEAT
CA156	LUGGAGE COMPARTMENT, RH SIDE
FC38	UNDER CENTER OF INSTRUMENT PANEL, ON TRANSMISSION TUNNEL-
FH77	LH LOWER 'A' POST, ADJACENT TO THE GENERAL ELECTRONIC CONTROL MODULE (FORWARD OF CA30)

FOR CONTROL MODULE PIN-OUT INFORMATION, UNFOLD PAGE TO LEFT.

Refer to the front of this book for detailed information and illustrations regarding the location and identification of harnesses, relays, fuses, grounds, control modules and control module pins.

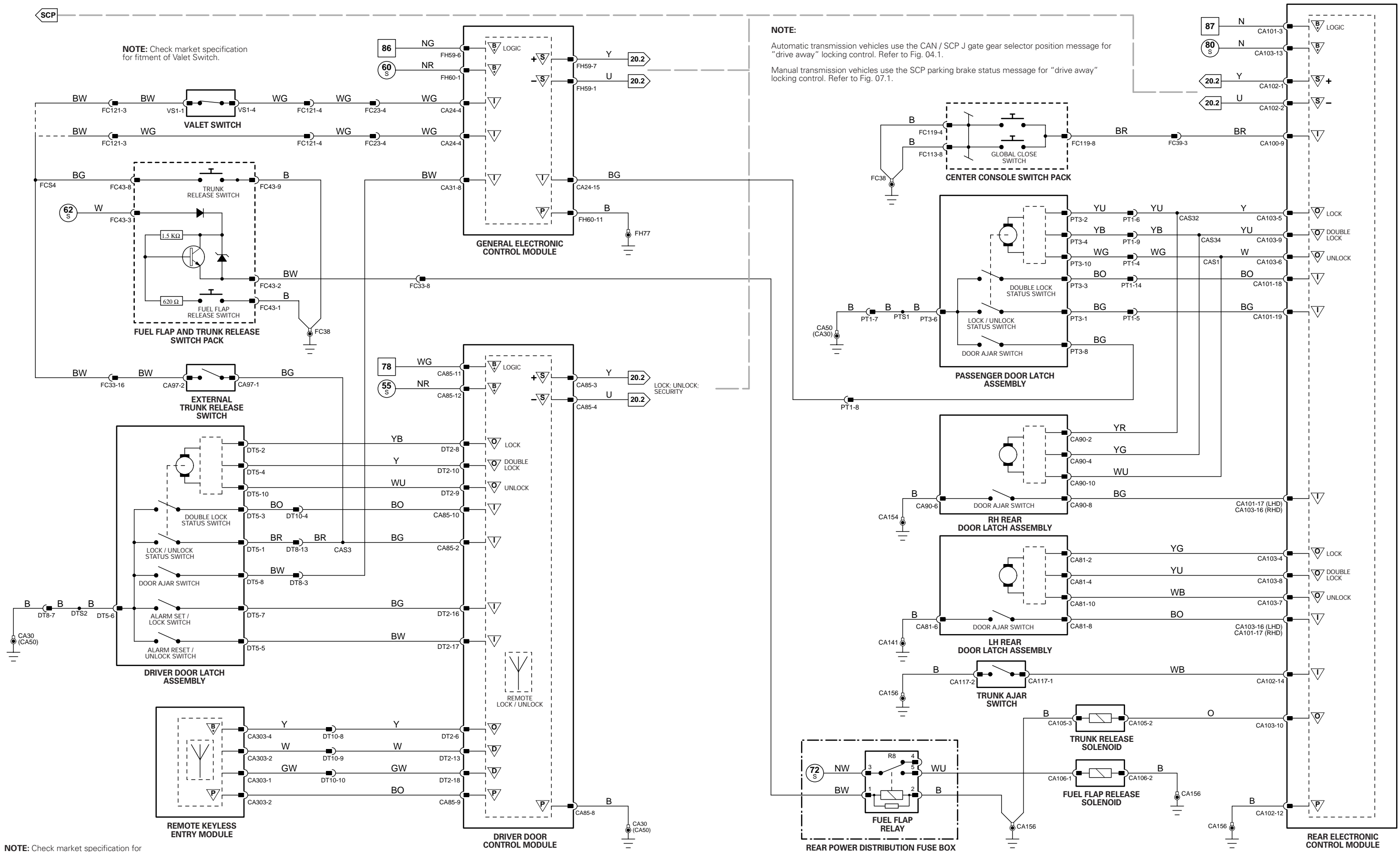

NOTE: Check market specification for fitment of Remote Keyless Entry.

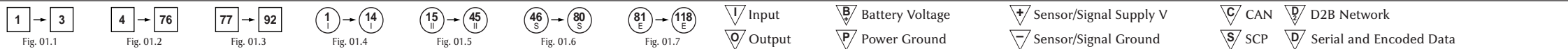

VARIANT: Double Locking Vehicles
VIN RANGE: All
DATE OF ISSUE: June 2002

CONTROL MODULE PIN-OUT INFORMATION

Driver Door Control Module

Pin	Description and Characteristic
I CA85-2	LOCK / UNLOCK STATUS SWITCH (NORMALLY OPEN): OPEN CIRCUIT / GROUND
S CA85-3	SCP +
S CA85-4	SCP -
PG CA85-8	POWER GROUND: GROUND
B+ CA85-11	BATTERY POWER SUPPLY: B+
B+ CA85-12	SWITCHED SYSTEM POWER SUPPLY: B+
O DT2-8	LOCK DRIVE: TO ACTIVATE, DDCM SWITCHES CIRCUIT TO B+
O DT2-9	UNLOCK DRIVE: TO ACTIVATE, DDCM SWITCHES CIRCUIT TO B+
I DT2-16	DRIVER DOOR ALARM SET / LOCK SWITCH (NORMALLY OPEN): OPEN CIRCUIT / GROUND
I DT2-17	DRIVER DOOR ALARM RESET / UNLOCK SWITCH (NORMALLY OPEN): OPEN CIRCUIT / GROUND

General Electronic Control Module

Pin	Description and Characteristic
I CA24-4	EXTERNAL TRUNK RELEASE SWITCH (NORMALLY OPEN) / VALET SWITCH (NORMALLY CLOSED): OPEN CIRCUIT / GROUND
I CA24-15	PASSENGER DOOR AJAR SWITCH (NORMALLY OPEN): OPEN CIRCUIT / GROUND
I CA31-8	DRIVER DOOR AJAR SWITCH (NORMALLY OPEN): OPEN CIRCUIT / GROUND
S FH59-1	SCP -
B+ FH59-6	BATTERY POWER SUPPLY (LOGIC): B+
S FH59-7	SCP +
B+ FH60-1	SWITCHED SYSTEM POWER SUPPLY: B+
PG FH60-11	POWER GROUND: GROUND

Rear Electronic Control Module

Pin	Description and Characteristic
I CA100-9	GLOBAL CLOSE SWITCH (NORMALLY OPEN): OPEN CIRCUIT / GROUND
B+ CA101-3	BATTERY POWER SUPPLY: B+
I CA101-17	LHD - RH REAR DOOR AJAR SWITCH (NORMALLY OPEN): OPEN CIRCUIT / GROUND RHD - LH REAR DOOR AJAR SWITCH (NORMALLY OPEN): OPEN CIRCUIT / GROUND
I CA101-19	LOCK / UNLOCK STATUS SWITCH (NORMALLY OPEN): OPEN CIRCUIT / GROUND
S CA102-1	SCP +
S CA102-2	SCP -
PG CA102-12	POWER GROUND: GROUND
I CA102-14	TRUNK AJAR SWITCH (NORMALLY OPEN): OPEN CIRCUIT / GROUND
O CA103-4	LOCK DRIVE: TO ACTIVATE, DDCM SWITCHES CIRCUIT TO B+
O CA103-5	LOCK DRIVE: TO ACTIVATE, DDCM SWITCHES CIRCUIT TO B+
O CA103-6	UNLOCK DRIVE: TO ACTIVATE, DDCM SWITCHES CIRCUIT TO B+
O CA103-7	UNLOCK DRIVE: TO ACTIVATE, DDCM SWITCHES CIRCUIT TO B+
O CA103-10	TRUNK RELEASE DRIVE: TO ACTIVATE, DDCM SWITCHES CIRCUIT TO B+
B+ CA103-13	SWITCHED SYSTEM POWER SUPPLY: B+
I CA103-16	LHD - LH REAR DOOR AJAR SWITCH (NORMALLY OPEN): OPEN CIRCUIT / GROUND RHD - RH REAR DOOR AJAR SWITCH (NORMALLY OPEN): OPEN CIRCUIT / GROUND

NOTE: Refer to the Appendix at the rear of this book for Network Messages.

The following abbreviations are used to represent values for Control Module Pin-Out data

I	Input	PG	Power Ground	C	CAN Network	D	Serial and Encoded Data
O	Output	SS	Sensor / Signal Supply V	S	SCP Network	V	Voltage (DC)
B+	Battery Voltage	SG	Sensor / Signal Ground	D2	D2B Network	PWM	Pulse Width Modulated

CAUTION: The information on this data page is furnished to aid the user in understanding circuit operation. THIS INFORMATION SHOULD BE USED FOR REFERENCE ONLY.

NOTE: The values listed are approximately those that can be expected at the control module connector pins with all circuit connections made and all components connected and fitted.

Fig. 12.2

COMPONENTS

Component	Connector(s)	Connector Description	Location
CENTER CONSOLE SWITCH PACK	FC113 FC119	8-WAY / BLACK 8-WAY / BLACK	CENTER CONSOLE
DOOR LATCH ASSEMBLY - DRIVER	DT5	10-WAY / BLACK	DRIVER DOOR
DOOR LATCH ASSEMBLY - RH REAR	CA90	10-WAY / BLACK	RH REAR DOOR
DOOR LATCH ASSEMBLY - LH REAR	CA81	10-WAY / BLACK	LH REAR DOOR
DOOR LATCH ASSEMBLY - PASSENGER	PT3	10-WAY / BLACK	PASSENGER DOOR
DRIVER DOOR CONTROL MODULE	CA85 DD4 DT2	12-WAY / BLACK 26-WAY / NATURAL 20-WAY / BLACK	DRIVER DOOR
EXTERNAL TRUNK RELEASE SWITCH	CA97	2-WAY / BLACK	LUGGAGE COMPARTMENT LID
FUEL FLAP AND TRUNK RELEASE SWITCH PACK	FC43	10-WAY / GREY	INSTRUMENT PANEL
FUEL FLAP RELAY	—	—	REAR POWER DISTRIBUTION FUSE BOX - R8
FUEL FLAP RELEASE SOLENOID	CA106	2-WAY / GREY	LUGGAGE COMPARTMENT, RH SIDE, FRONT
GENERAL ELECTRONIC CONTROL MODULE	FH9 CA24 CA31 FH59 FH60	22-WAY / BLACK 26-WAY / NATURAL 20-WAY / BLACK 12-WAY / BLACK 17-WAY / BLACK	LH 'A' POST
REAR ELECTRONIC CONTROL MODULE	CA63 CA100 CA101 CA102 CA103	17-WAY / BLACK 12-WAY / BLACK 20-WAY / BLACK 22-WAY / BLACK 26-WAY / NATURAL	LUGGAGE COMPARTMENT, RH REAR
REAR POWER DISTRIBUTION FUSE BOX	—	—	LUGGAGE COMPARTMENT
TRUNK AJAR SWITCH	CA117	2-WAY / BLACK	LUGGAGE COMPARTMENT LID
TRUNK RELEASE SOLENOID	CA105	3-WAY / BLACK	LUGGAGE COMPARTMENT LID
VALET SWITCH	VS1	6-WAY / BLACK	GLOVE BOX

HARNES IN-LINE CONNECTORS

Connector	Connector Description / Location	Location
DT8	14-WAY / GREY / CABIN HARNESS TO DRIVER DOOR TRIM HARNESS	DRIVER DOOR
FC121	4-WAY / GREY / FASCIA HARNESS IN-LINE CONNECTOR	BEHIND GLOVE BOX
FC23	10-WAY / GREY / CABIN HARNESS TO FASCIA HARNESS	BEHIND INSTRUMENT PANEL, LH SIDE
FC33	16-WAY / GREEN / CABIN HARNESS TO FASCIA HARNESS	BEHIND INSTRUMENT PANEL, RH SIDE
FC39	10-WAY / GREY / CABIN HARNESS TO FASCIA HARNESS	BEHIND INSTRUMENT PANEL, RH SIDE
PT1	14-WAY / GREY / CABIN HARNESS TO PASSENGER DOOR TRIM HARNESS	PASSENGER DOOR

GROUND S

Ground	Location
CA30	LH LOWER 'A' POST, ADJACENT TO THE GENERAL ELECTRONIC CONTROL MODULE (REARWARD OF FH77)
CA50	RH LOWER 'A' POST, BELOW PRIMARY JUNCTION FUSE BOX
CA141	UNDER LH FRONT SEAT
CA154	UNDER RH FRONT SEAT
CA156	LUGGAGE COMPARTMENT, RH SIDE
FC38	UNDER CENTER OF INSTRUMENT PANEL, ON TRANSMISSION TUNNEL
FH77	LH LOWER 'A' POST, ADJACENT TO THE GENERAL ELECTRONIC CONTROL MODULE (FORWARD OF CA30)

FOR CONTROL MODULE PIN-OUT INFORMATION, UNFOLD PAGE TO LEFT.

Refer to the front of this book for detailed information and illustrations regarding the location and identification of harnesses, relays, fuses, grounds, control modules and control module pins.

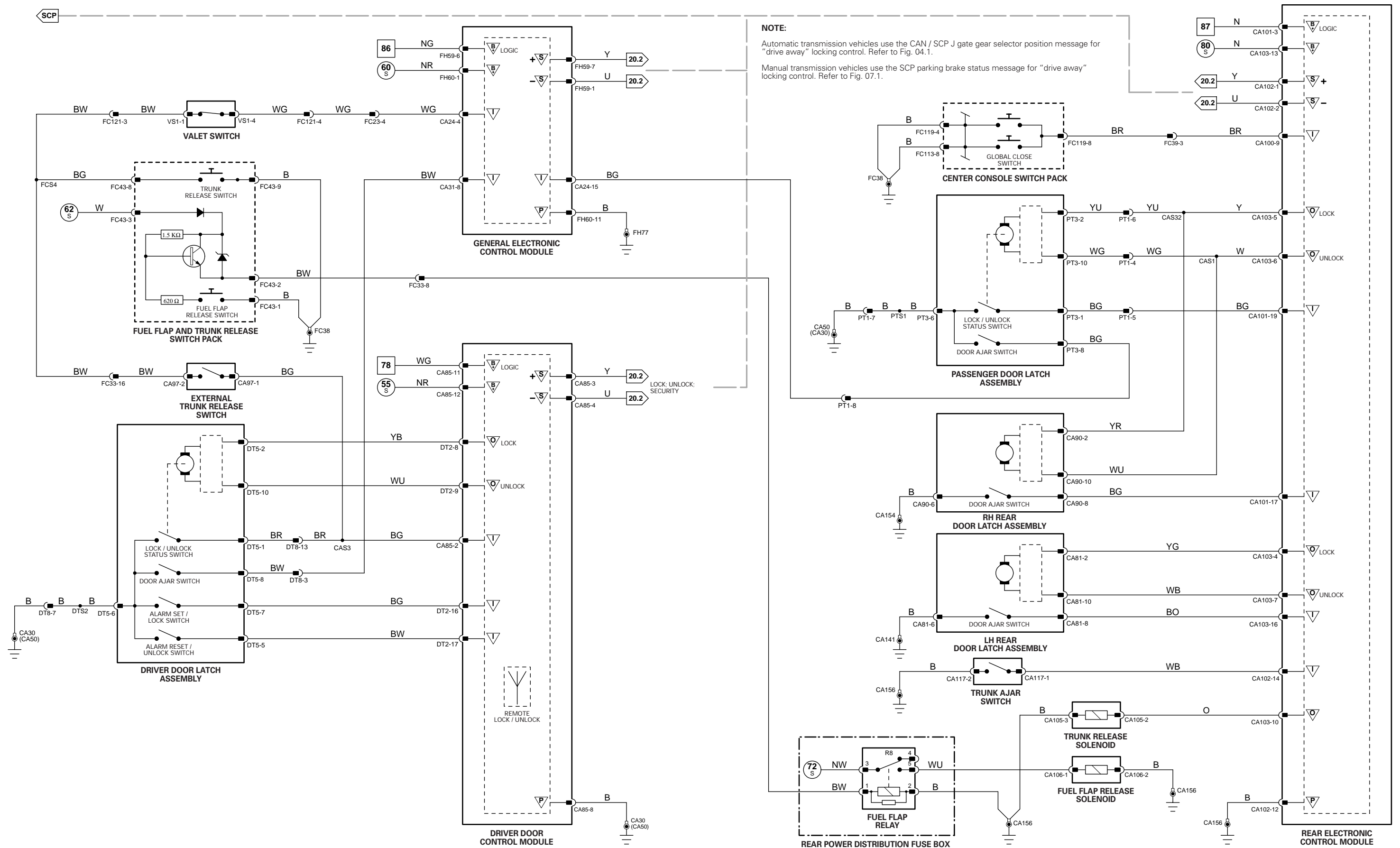

NOTE:
 Automatic transmission vehicles use the CAN / SCP J gate gear selector position message for "drive away" locking control. Refer to Fig. 04.1.
 Manual transmission vehicles use the SCP parking brake status message for "drive away" locking control. Refer to Fig. 07.1.

1 → 3 Fig. 01.1	4 → 76 Fig. 01.2	77 → 92 Fig. 01.3	1 → 14 Fig. 01.4	15 → 45 Fig. 01.5	46 → 80 Fig. 01.6	81 → 118 Fig. 01.7	Input	Battery Voltage	Sensor/Signal Supply V	CAN	D2B Network
							Output	Power Ground	Sensor/Signal Ground	SCP	Serial and Encoded Data

VARIANT: Non Double Locking Vehicles
 VIN RANGE: All
 DATE OF ISSUE: June 2002

CONTROL MODULE PIN-OUT INFORMATION

Audio Unit

Pin	Description and Characteristic
O FC94-8	SECURITY SYSTEM GROUND SENSING: GROUND WHEN AUDIO UNIT INSTALLED

Driver Door Control Module

Pin	Description and Characteristic
I CA85-2	LOCK / UNLOCK STATUS SWITCH (NORMALLY OPEN): OPEN CIRCUIT / GROUND
S CA85-3	SCP +
S CA85-4	SCP -
PG CA85-8	POWER GROUND: GROUND
PG CA85-9	REMOTE KEYLESS ENTRY MODULE GROUND: GROUND
I CA85-10	DOUBLE LOCK STATUS SWITCH (NORMALLY OPEN): OPEN CIRCUIT / GROUND
B+ CA85-11	BATTERY POWER SUPPLY: B+
B+ CA85-12	SWITCHED SYSTEM POWER SUPPLY: B+
O DT2-6	REMOTE KEYLESS ENTRY MODULE POWER SUPPLY: B+
O DT2-8	LOCK DRIVE: TO ACTIVATE, DDCM SWITCHES CIRCUIT TO B+
O DT2-9	UNLOCK DRIVE: TO ACTIVATE, DDCM SWITCHES CIRCUIT TO B+
O DT2-10	DOUBLE LOCK DRIVE: TO ACTIVATE, DDCM SWITCHES CIRCUIT TO B+
D DT2-13	REMOTE KEYLESS ENTRY MODULE SIGNAL: ENCODED COMMUNICATIONS
I DT2-16	DRIVER DOOR ALARM SET / LOCK SWITCH (NORMALLY OPEN): OPEN CIRCUIT / GROUND
I DT2-17	DRIVER DOOR ALARM RESET / UNLOCK SWITCH (NORMALLY OPEN): OPEN CIRCUIT / GROUND
D DT2-18	REMOTE KEYLESS ENTRY MODULE SIGNAL: ENCODED COMMUNICATIONS

Engine Control Module

Pin	Description and Characteristic
C P11-123	CAN -
C P11-124	CAN +

General Electronic Control Module

Pin	Description and Characteristic
I CA24-15	PASSENGER DOOR AJAR SWITCH (NORMALLY OPEN): OPEN CIRCUIT / GROUND
I CA31-3	IGNITION SWITCHED VOLTAGE SIGNAL (I): B+
I CA31-5	RECM SECURITY GROUND SENSE: OPEN CIRCUIT IF RECM REMOVED
I CA31-7	AUDIO UNIT SECURITY GROUND SENSE: OPEN CIRCUIT IF AUDIO UNIT REMOVED
I CA31-8	DRIVER DOOR AJAR SWITCH (NORMALLY OPEN): OPEN CIRCUIT / GROUND
I CA31-18	INTRUSION AND INCLINATION SENSORS SIGNAL: GROUND (PULSED)
O FH9-16	INTRUSION AND INCLINATION SENSORS SUPPLY VOLTAGE: B+
S FH59-1	SCP -
I FH59-3	HOOD AJAR SWITCH (NORMALLY OPEN): OPEN CIRCUIT / GROUND
B+ FH59-6	BATTERY POWER SUPPLY (LOGIC): B+
S FH59-7	SCP +
O FH59-8	HORN RELAY ACTIVATE: TO ACTIVATE, GECM SWITCHES CIRCUIT TO GROUND
B+ FH60-1	SWITCHED SYSTEM POWER SUPPLY: B+
O FH60-3	ACTIVE SECURITY SOUNDER ACTIVATE: ENCODED COMMUNICATION
O FH60-4	RH FRONT TURN SIGNAL ACTIVATE: TO ACTIVATE, GECM SWITCHES CIRCUIT TO GROUND (PULSED)
O FH60-5	LH FRONT TURN SIGNAL ACTIVATE: TO ACTIVATE, GECM SWITCHES CIRCUIT TO GROUND (PULSED)
PG FH60-6	STEERING COLUMN LOCK CONTROL MODULE POWER GROUND SUPPLY: GROUND
PG FH60-11	POWER GROUND: GROUND
O FH60-16	PASSIVE SECURITY SOUNDER ACTIVATE: TO ACTIVATE, GECM SWITCHES CIRCUIT TO B+

Instrument Cluster

Pin	Description and Characteristic
I FC14-2	KEY-IN AUDIBLE WARNING: B+ WHEN KEY IN
B+ FC14-3	IGNITION SWITCHED POWER SUPPLY (I): B+
O FC14-10	SECURITY INDICATOR DRIVE: ACTIVE = PULSED GROUND
SG FC14-14	SIGNAL GROUND: GROUND
PG FC15-2	POWER GROUND: GROUND
B+ FC15-3	BATTERY POWER SUPPLY (LOGIC): B+
I FC15-4	PATS GROUND: GROUND
D FC15-5	PATS TRANSCIEVER: ENCODED COMMUNICATION
D FC15-6	PATS TRANSCIEVER: ENCODED COMMUNICATION
S FC15-10	SCP -
C FC15-18	CAN +
C FC15-19	CAN -
S FC15-20	SCP +

Rear Electronic Control Module

Pin	Description and Characteristic
O CA63-3	LH REAR TURN SIGNAL ACTIVATE: TO ACTIVATE, RECM SWITCHES CIRCUIT TO GROUND (PULSED)
O CA63-4	RH REAR TURN SIGNAL ACTIVATE: TO ACTIVATE, RECM SWITCHES CIRCUIT TO GROUND (PULSED)
O CA100-1	STEERING COLUMN LOCK CONTROL MODULE SUPPLY VOLTAGE: B+
B+ CA101-3	BATTERY POWER SUPPLY: B+
O CA101-5	RECM SECURITY GROUND SENSE: OPEN CIRCUIT IF RECM REMOVED
I CA101-17	LHD - RH REAR DOOR AJAR SWITCH (NORMALLY OPEN): OPEN CIRCUIT / GROUND RHD - LH REAR DOOR AJAR SWITCH (NORMALLY OPEN): OPEN CIRCUIT / GROUND
S CA102-1	SCP +
S CA102-2	SCP -
PG CA102-12	POWER GROUND: GROUND
I CA102-14	TRUNK AJAR SWITCH (NORMALLY OPEN): OPEN CIRCUIT / GROUND
B+ CA103-13	SWITCHED SYSTEM POWER SUPPLY: B+
I CA103-16	LHD - LH REAR DOOR AJAR SWITCH (NORMALLY OPEN): OPEN CIRCUIT / GROUND RHD - RH REAR DOOR AJAR SWITCH (NORMALLY OPEN): OPEN CIRCUIT / GROUND

NOTE: Refer to the Appendix at the rear of this book for Network Messages.

The following abbreviations are used to represent values for Control Module Pin-Out data

I	Input	PG	Power Ground	C	CAN Network	D	Serial and Encoded Data
O	Output	SS	Sensor / Signal Supply V	S	SCP Network	V	Voltage (DC)
B+	Battery Voltage	SG	Sensor / Signal Ground	D2	D2B Network	PWM	Pulse Width Modulated

CAUTION: The information on this data page is furnished to aid the user in understanding circuit operation. THIS INFORMATION SHOULD BE USED FOR REFERENCE ONLY.

NOTE: The values listed are approximately those that can be expected at the control module connector pins with all circuit connections made and all components connected and fitted.

Fig. 12.3

COMPONENTS

Component	Connector(s)	Connector Description	Location
ACTIVE SECURITY SOUNDER	AT4	3-WAY / BLACK	ENGINE COMPARTMENT, REARWARD OF RH HEADLAMP UNIT
AUDIO UNIT	FC94 FC96 FC96 FC108	20-WAY / BLACK ANTENNA CONNECTOR FIBER OPTIC CONNECTOR	CENTER CONSOLE
DOOR LATCH ASSEMBLY - DRIVER	DT5	10-WAY / BLACK	DRIVER DOOR
DOOR LATCH ASSEMBLY - LH REAR	CA81	10-WAY / BLACK	LH REAR DOOR
DOOR LATCH ASSEMBLY - PASSENGER	PT3	10-WAY / BLACK	PASSENGER DOOR
DOOR LATCH ASSEMBLY - RH REAR	CA90	10-WAY / BLACK	RH REAR DOOR
DRIVER DOOR CONTROL MODULE	CA85 DD4 DT2	12-WAY / BLACK 26-WAY / NATURAL 20-WAY / BLACK	DRIVER DOOR
ENGINE CONTROL MODULE	PI1	134-WAY / BLACK	FRONT BULKHEAD, PASSENGER SIDE
FRONT POWER DISTRIBUTION FUSE BOX	—	—	ENGINE COMPARTMENT, RH SIDE
GENERAL ELECTRONIC CONTROL MODULE	FH9 CA24 CA31 FH59 FH60	22-WAY / BLACK 26-WAY / NATURAL 20-WAY / BLACK 12-WAY / BLACK 17-WAY / BLACK	LH 'A' POST
HOOD AJAR SWITCH	FH21	2-WAY / BLACK	ENGINE COMPARTMENT, ADJACENT TO RH SUSPENSION TURRET
HORN RELAY	—	—	FRONT POWER DISTRIBUTION FUSE BOX - R12
HORNS	FH29	2-WAY / BLACK	FORWARD OF RADIATOR
IGNITION SWITCH	FC18	7-WAY / BLACK	STEERING COLUMN COWLING
INCLINATION SENSOR	CA173	4-WAY / GREY	LUGGAGE COMPARTMENT, LH REAR
INSTRUMENT CLUSTER	FC14 FC15 FC63	22-WAY / GREY 20-WAY / BLACK 22-WAY / BLACK	INSTRUMENT PANEL
PASSIVE ANTI-THEFT SYSTEM TRANSCIEVER	FC52	4-WAY / GREEN	STEERING COLUMN, IGNITION SWITCH
PASSIVE SECURITY SOUNDER	AT2 AT3	1-WAY / BLACK 1-WAY / BLACK	ENGINE COMPARTMENT, REARWARD OF RH HEADLAMP UNIT
REAR ELECTRONIC CONTROL MODULE	CA63 CA100 CA101 CA102 CA103	17-WAY / BLACK 12-WAY / BLACK 20-WAY / BLACK 22-WAY / BLACK 26-WAY / NATURAL	LUGGAGE COMPARTMENT, RH REAR
REMOTE KEYLESS ENTRY MODULE	CA303	4-WAY / BLACK	UNDER CENTER CONSOLE
ROOF CONSOLE	CA250	22-WAY / BLACK	ROOF HEADLINER
SECURITY INDICATOR	SL1	6-WAY / BLACK	INSTRUMENT PANEL GLARE SHIELD, FRONT CENTER
STEERING COLUMN LOCK CONTROL MODULE	FC59	4-WAY / BLACK	ADJACENT TO STEERING COLUMN LOCK
TRUNK AJAR SWITCH	CA117	2-WAY / BLACK	LUGGAGE COMPARTMENT LID

HARNESS IN-LINE CONNECTORS

Connector	Connector Description / Location	Location
DT10	10-WAY / GREY / CABIN HARNESS TO DRIVER DOOR TRIM HARNESS	DRIVER DOOR
DT8	14-WAY / GREY / CABIN HARNESS TO DRIVER DOOR TRIM HARNESS	DRIVER DOOR
FC4	14-WAY / GREEN / FASCIA HARNESS IN-LINE CONNECTOR	BEHIND INSTRUMENT PANEL, LH SIDE
FC23	10-WAY / GREY / CABIN HARNESS TO FASCIA HARNESS	BEHIND INSTRUMENT PANEL, LH SIDE
FC39	10-WAY / GREY / CABIN HARNESS TO FASCIA HARNESS	BEHIND INSTRUMENT PANEL, RH SIDE
FH6	16-WAY GREEN / CABIN HARNESS TO FRONT HARNESS	LH 'A' POST, ADJACENT TO GECM
FH89	4-WAY / GREY / FRONT HARNESS TO ALARM LINK	ADJACENT TO FRONT POWER DISTRIBUTION FUSE BOX
PT1	14-WAY / GREY / CABIN HARNESS TO PASSENGER DOOR TRIM HARNESS	PASSENGER DOOR
SL3	10-WAY / GREY / FASCIA HARNESS TO SOLAR SENSOR LINK	BEHIND INSTRUMENT PANEL, RH SIDE

GROUNDS

Ground	Location
CA30	LH LOWER 'A' POST, ADJACENT TO THE GENERAL ELECTRONIC CONTROL MODULE (REARWARD OF FH77)
CA50	RH LOWER 'A' POST, BELOW PRIMARY JUNCTION FUSE BOX
CA141	UNDER LH FRONT SEAT
CA154	UNDER RH FRONT SEAT
CA156	LUGGAGE COMPARTMENT, RH SIDE
CA158	LUGGAGE COMPARTMENT, LH SIDE REAR CORNER
FC38	UNDER CENTER OF INSTRUMENT PANEL, ON TRANSMISSION TUNNEL
FH22	ENGINE COMPARTMENT, BEHIND LH HEADLAMP
FH42	ENGINE COMPARTMENT, BEHIND RH HEADLAMP
FH77	LH LOWER 'A' POST, ADJACENT TO THE GENERAL ELECTRONIC CONTROL MODULE (FORWARD OF CA30)

FOR CONTROL MODULE PIN-OUT INFORMATION, UNFOLD PAGE TO LEFT.

Refer to the front of this book for detailed information and illustrations regarding the location and identification of harnesses, relays, fuses, grounds, control modules and control module pins.

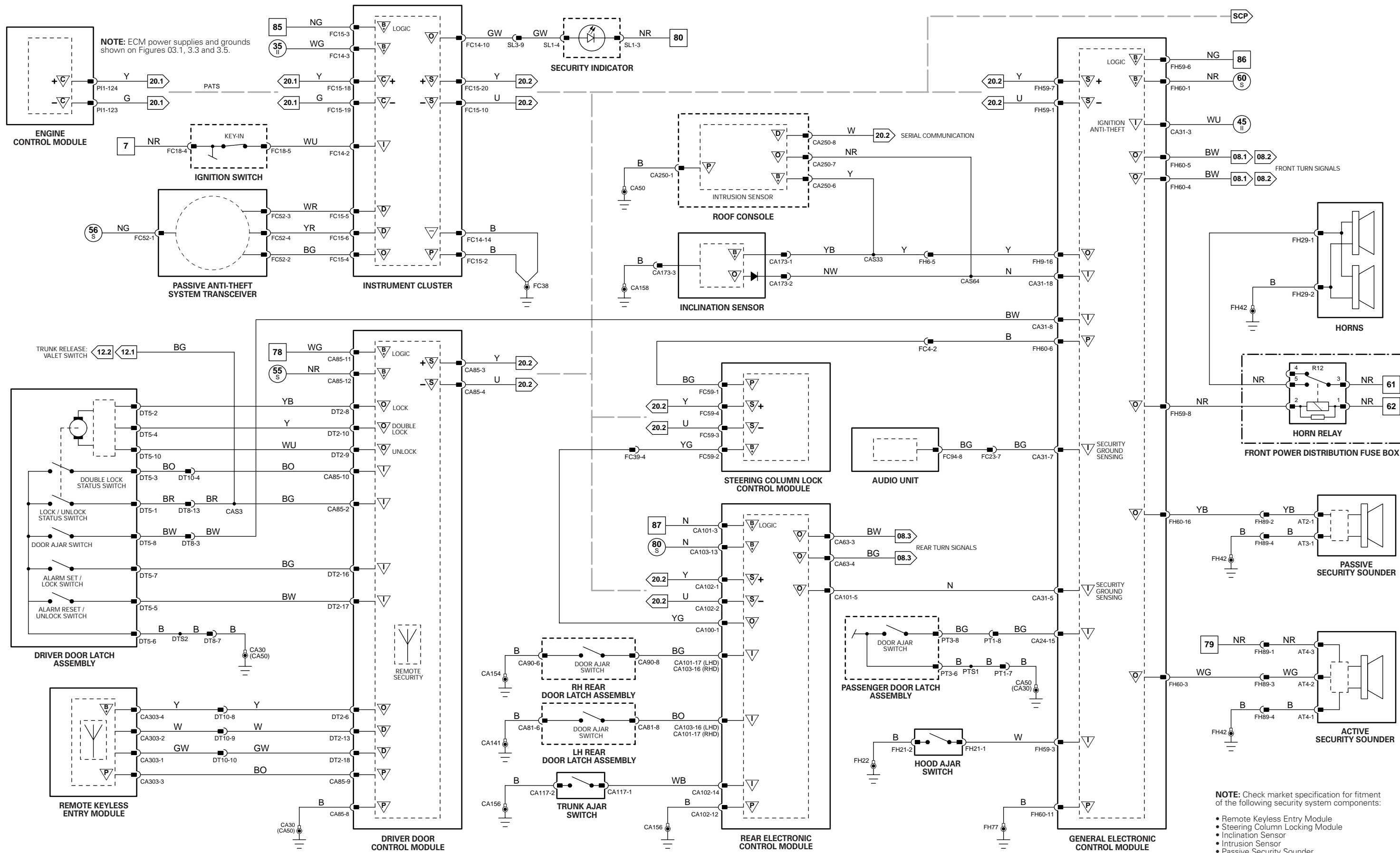

CONTROL MODULE PIN-OUT INFORMATION

General Electronic Control Module

Pin	Description and Characteristic
I CA31-2	WIPER MODE SELECT: VARIABLE RESISTANCE
I CA31-13	WIPER DELAY / WASH: VARIABLE RESISTANCE
SG CA31-14	WIPE / WASH SWITCH SIGNAL GROUND: GROUND
O FH9-1	WIPER PARK RELAY ACTIVATE: TO ACTIVATE, GECM SWITCHES CIRCUIT TO GROUND
O FH9-3	WIPER HIGH / LOW RELAY ACTIVATE: TO ACTIVATE, GECM SWITCHES CIRCUIT TO GROUND
I FH9-13	WIPER PARK: PARK = GROUND
O FH9-14	WINDSHIELD WASHER PUMP DRIVE: TO ACTIVATE, GECM SWITCHES CIRCUIT TO B+
I FH9-15	WASHER FLUID LEVEL SWITCH (NORMALLY OPEN): OPEN CIRCUIT / GROUND
S FH59-1	SCP -
O FH59-4	POWER WASH RELAY ACTIVATE: TO ACTIVATE, GECM SWITCHES CIRCUIT TO GROUND
S FH59-7	SCP +
B+ FH60-1	SWITCHED SYSTEM POWER SUPPLY: B+
PG FH60-11	POWER GROUND: GROUND

NOTE: Refer to the Appendix at the rear of this book for Network Messages.

Fig. 13.1

COMPONENTS

Component	Connector(s)	Connector Description	Location
FRONT POWER DISTRIBUTION FUSE BOX	—	—	ENGINE COMPARTMENT, RH SIDE
GENERAL ELECTRONIC CONTROL MODULE	FH9 CA24 CA31 FH59 FH60	22-WAY / BLACK 26-WAY / NATURAL 20-WAY / BLACK 12-WAY / BLACK 17-WAY / BLACK	LH 'A' POST
POWER WASH PUMP	FH38	2-WAY / BLACK	ENGINE COMPARTMENT, WASHER FLUID TANK
POWER WASH RELAY	—	—	FRONT POWER DISTRIBUTION FUSE BOX – R18
RAIN SENSING MODULE	CA248	12-WAY / BLACK	LUGGAGE COMPARTMENT, UNDER PARCEL SHELF
RAIN SENSING UNIT	RF14	3-WAY / BLACK	REAR VIEW MIRROR
WASHER FLUID LEVEL SWITCH	FH37	2-WAY / BLACK	WASHER FLUID CONTAINER
WINDSHIELD WASHER PUMP	FH36	5-WAY / GREEN	ENGINE COMPARTMENT, ADJACENT TO WASHER FLUID CONTAINER
WIPE / WASH SWITCH	FC118	6-WAY / BLACK	STEERING COLUMN STALK
WIPER HIGH / LOW RELAY	—	—	FRONT POWER DISTRIBUTION FUSE BOX – R15
WIPER MOTOR ASSEMBLY	FH17	6-WAY / BLACK	ENGINE COMPARTMENT, BULKHEAD
WIPER PARK RELAY	—	—	FRONT POWER DISTRIBUTION FUSE BOX – R16

HARNESS IN-LINE CONNECTORS

Connector	Connector Description / Location	Location
FC19	16-WAY / GREEN / CABIN HARNESS TO FASCIA HARNESS	BEHIND INSTRUMENT PANEL, LH SIDE
FH1	20-WAY / BLACK / CABIN HARNESS TO FRONT HARNESS	RH 'A' POST, LOWER
RF34	16-WAY / GREEN / CABIN HARNESS TO DOOR HARNESS	'D' POST, UNDER PARCEL SHELF

GROUNDS

Ground	Location
CA116	BEHIND REAR SEAT BACK, RH SIDE
FH22	ENGINE COMPARTMENT, BEHIND LH HEADLAMP
FH42	ENGINE COMPARTMENT, BEHIND RH HEADLAMP
FH77	LH LOWER 'A' POST, ADJACENT TO THE GENERAL ELECTRONIC CONTROL MODULE (FORWARD OF CA30)

FOR CONTROL MODULE PIN-OUT INFORMATION, UNFOLD PAGE TO LEFT.

The following abbreviations are used to represent values for Control Module Pin-Out data

I	Input	PG	Power Ground	C	CAN Network	D	Serial and Encoded Data
O	Output	SS	Sensor / Signal Supply V	S	SCP Network	V	Voltage (DC)
B+	Battery Voltage	SG	Sensor / Signal Ground	D2	D2B Network	PWM	Pulse Width Modulated

CAUTION: The information on this data page is furnished to aid the user in understanding circuit operation. THIS INFORMATION SHOULD BE USED FOR REFERENCE ONLY.

NOTE: The values listed are approximately those that can be expected at the control module connector pins with all circuit connections made and all components connected and fitted.

Refer to the front of this book for detailed information and illustrations regarding the location and identification of harnesses, relays, fuses, grounds, control modules and control module pins.

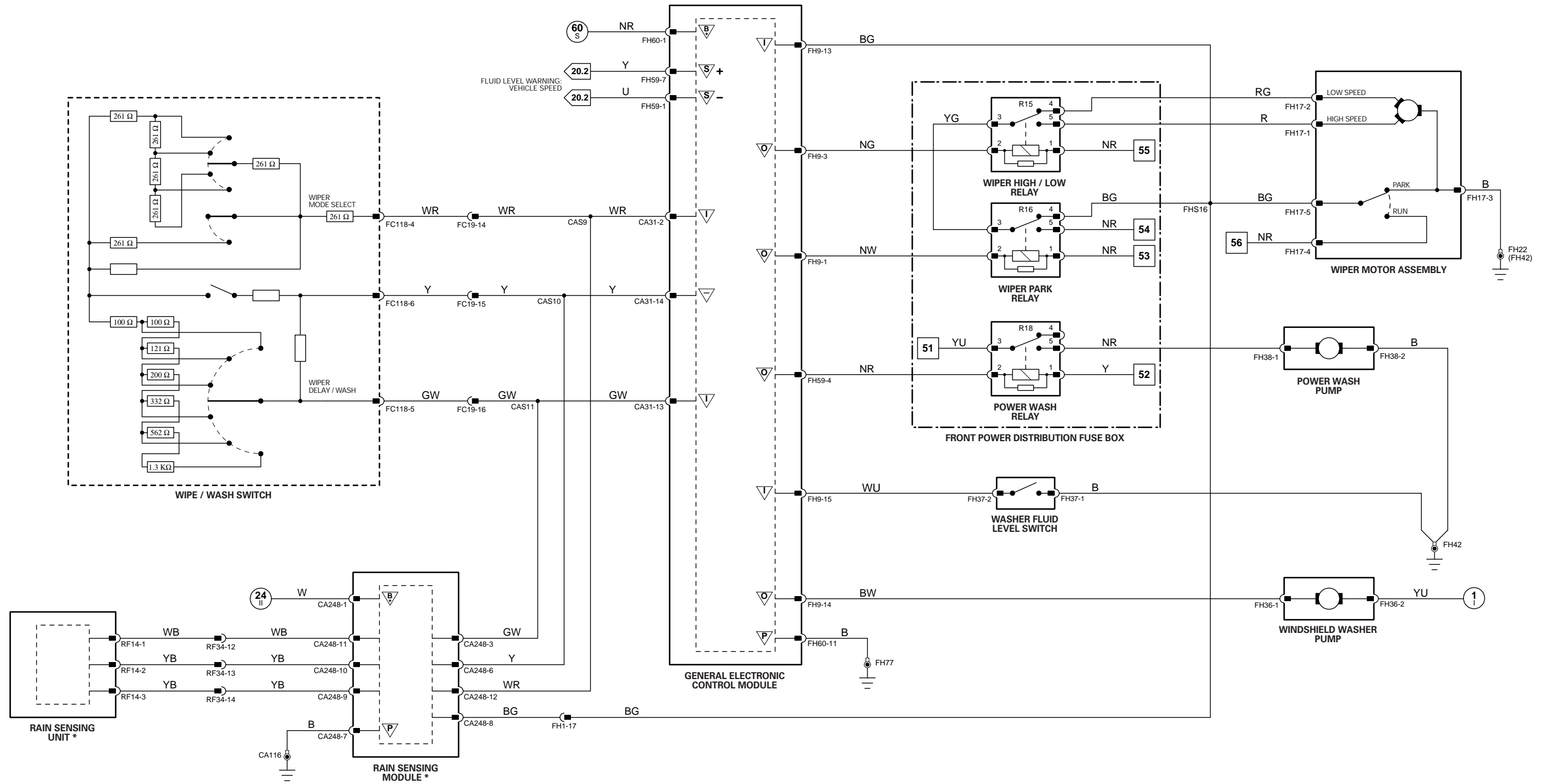

* NOTE: Rain sensing system – rain sensing vehicles only.

CONTROL MODULE PIN-OUT INFORMATION

Driver Door Control Module

Pin	Description and Characteristic
S CA85-3	SCP +
S CA85-4	SCP -
PG CA85-8	POWER GROUND: GROUND
B+ CA85-11	BATTERY POWER SUPPLY: B+
B+ CA85-12	SWITCHED SYSTEM POWER SUPPLY: B+
O DD4-1	POWER WINDOWS ENABLE: TO ACTIVATE, DDCM SWITCHES CIRCUIT TO B+
O DD4-26	GLOBAL CLOSE SIGNAL: 20 ms PULSED SIGNAL
I DT2-16	DRIVER DOOR ALARM SET / LOCK SWITCH (NORMALLY OPEN): OPEN CIRCUIT / GROUND
I DT2-17	DRIVER DOOR ALARM RESET / UNLOCK SWITCH (NORMALLY OPEN): OPEN CIRCUIT / GROUND

Rear Electronic Control Module

Pin	Description and Characteristic
I CA100-9	GLOBAL CLOSE SWITCH (NORMALLY OPEN): OPEN CIRCUIT / GROUND
B+ CA101-3	BATTERY POWER SUPPLY: B+
S CA102-1	SCP +
S CA102-2	SCP -
PG CA102-12	POWER GROUND: GROUND
I CA102-13	BRAKE ON / OFF SWITCH (NORMALLY OPEN): OPEN CIRCUIT / B+

NOTE: Refer to the Appendix at the rear of this book for Network Messages.

Fig. 14.1

COMPONENTS

Component	Connector(s)	Connector Description	Location
CENTER CONSOLE SWITCH PACK	FC113 FC119	8-WAY / BLACK 8-WAY / BLACK	CENTER CONSOLE
DOOR LATCH ASSEMBLY – DRIVER	DT5	10-WAY / BLACK	DRIVER DOOR
DOOR SWITCH PACK – DRIVER	DD2	26-WAY / YELLOW	DRIVER DOOR ARM REST
DOOR SWITCH PACK – LH REAR	CA78	5-WAY / GREEN	LH REAR DOOR ARM REST
DOOR SWITCH PACK – PASSENGER	PD1	5-WAY / GREEN	PASSENGER DOOR ARM REST
DOOR SWITCH PACK – RH REAR	CA95	5-WAY / GREEN	RH REAR DOOR ARM REST
DRIVER DOOR CONTROL MODULE	CA85 DD4 DT2	12-WAY / BLACK 26-WAY / NATURAL 20-WAY / BLACK	DRIVER DOOR
REAR ELECTRONIC CONTROL MODULE	CA63 CA100 CA101 CA102 CA103	17-WAY / BLACK 12-WAY / BLACK 20-WAY / BLACK 22-WAY / BLACK 26-WAY / NATURAL	LUGGAGE COMPARTMENT, RH REAR
ROOF CONSOLE	CA250	22-WAY / BLACK	ROOF HEADLINER
SLIDING ROOF CONTROL MODULE	CA253	10-WAY / GREY	ABOVE ROOF CONSOLE
WINDOW MOTOR ASSEMBLY – DRIVER	DT4	8-WAY / GREY	DRIVER DOOR
WINDOW MOTOR ASSEMBLY – LH REAR	CA79	8-WAY / GREY	LH REAR DOOR
WINDOW MOTOR ASSEMBLY – PASSENGER	PT4	8-WAY / GREY	PASSENGER DOOR
WINDOW MOTOR ASSEMBLY – RH REAR	CA93	8-WAY / GREY	RH REAR DOOR

HARNESS IN-LINE CONNECTORS

Connector	Connector Description / Location	Location
DD8	16-WAY / BLUE / CABIN HARNESS TO DRIVER DOOR HARNESS	DRIVER DOOR
DT8	14-WAY / GREY / CABIN HARNESS TO DRIVER DOOR TRIM HARNESS	DRIVER DOOR
FC39	10-WAY / GREY / CABIN HARNESS TO FASCIA HARNESS	BEHIND INSTRUMENT PANEL, RH SIDE
FH1	20-WAY / BLACK / CABIN HARNESS TO FRONT HARNESS	RH 'A' POST, LOWER
PD4	10-WAY / GREY / CABIN HARNESS TO PASSENGER DOOR HARNESS	PASSENGER DOOR
PT1	14-WAY / GREY / CABIN HARNESS TO PASSENGER DOOR TRIM HARNESS	PASSENGER DOOR

GROUNDINGS

Ground	Location
CA30	LH LOWER 'A' POST, ADJACENT TO THE GENERAL ELECTRONIC CONTROL MODULE (REARWARD OF FH77)
CA50	RH LOWER 'A' POST, BELOW PRIMARY JUNCTION FUSE BOX
CA141	UNDER LH FRONT SEAT
CA154	UNDER RH FRONT SEAT
CA156	LUGGAGE COMPARTMENT, RH SIDE
FC38	UNDER CENTER OF INSTRUMENT PANEL, ON TRANSMISSION TUNNEL

FOR CONTROL MODULE PIN-OUT INFORMATION, UNFOLD PAGE TO LEFT.

The following abbreviations are used to represent values for Control Module Pin-Out data

I	Input	PG	Power Ground	C	CAN Network	D	Serial and Encoded Data
O	Output	SS	Sensor / Signal Supply V	S	SCP Network	V	Voltage (DC)
B+	Battery Voltage	SG	Sensor / Signal Ground	D2	D2B Network	PWM	Pulse Width Modulated

CAUTION: The information on this data page is furnished to aid the user in understanding circuit operation. THIS INFORMATION SHOULD BE USED FOR REFERENCE ONLY.

NOTE: The values listed are approximately those that can be expected at the control module connector pins with all circuit connections made and all components connected and fitted.

Refer to the front of this book for detailed information and illustrations regarding the location and identification of harnesses, relays, fuses, grounds, control modules and control module pins.

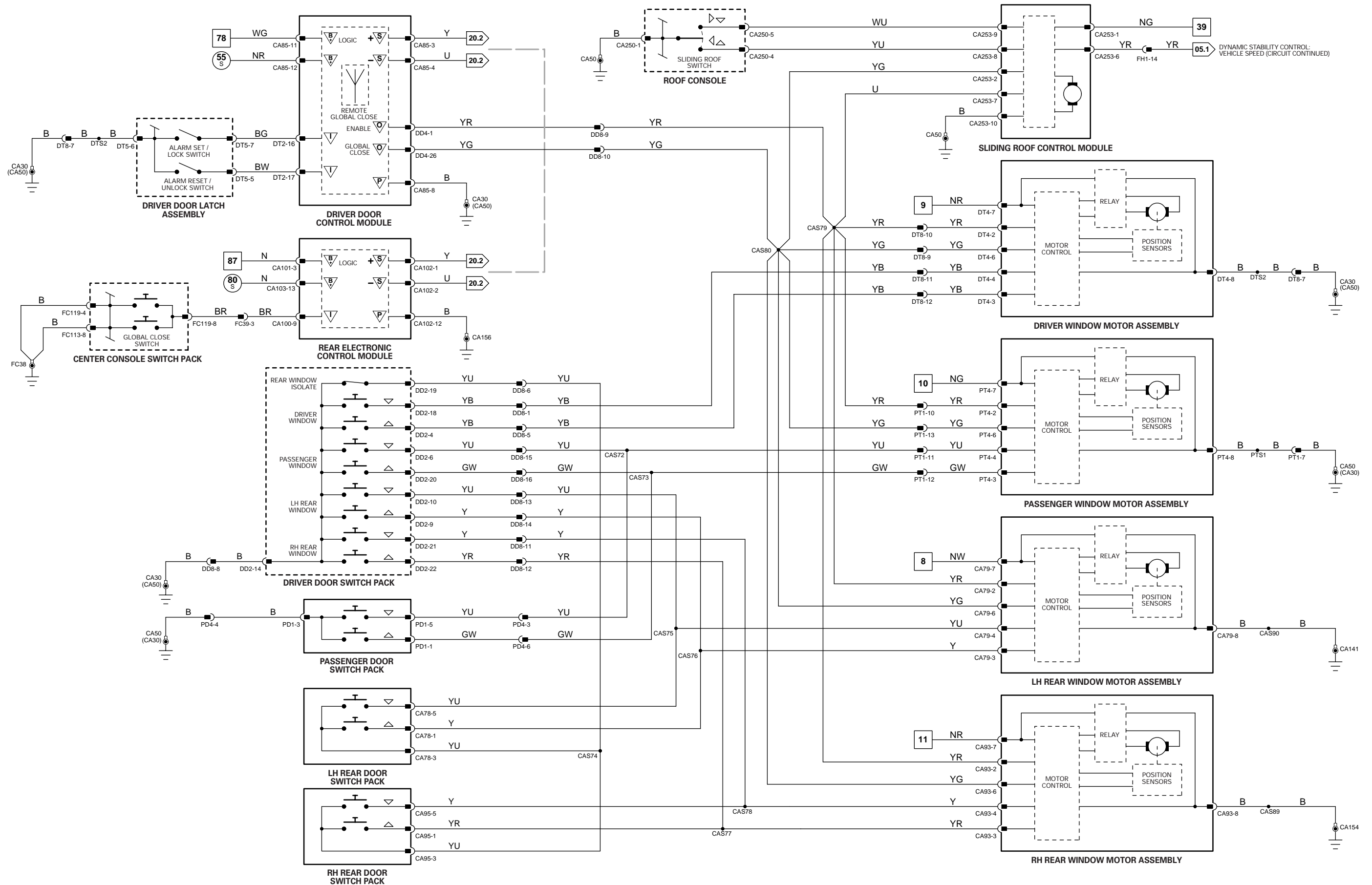

CONTROL MODULE PIN-OUT INFORMATION

Audio Unit – Standard

Pin	Description and Characteristic
PG	FC94-1 POWER GROUND: GROUND
B+	FC94-2 IGNITION SWITCHED POWER SUPPLY (I): B+
O	FC94-3 LH REAR AUDIO +
O	FC94-4 LH REAR AUDIO -
O	FC94-5 RH REAR AUDIO +
O	FC94-6 RH REAR AUDIO -
I	FC94-7 TELEPHONE MUTE SIGNAL
O	FC94-8 SECURITY SYSTEM GROUND SENSING: GROUND WHEN AUDIO UNIT INSTALLED
S	FC94-9 SCP +
S	FC94-10 SCP -
B+	FC94-11 BATTERY POWER SUPPLY: B+
O	FC94-13 LH FRONT AUDIO -
O	FC94-14 LH FRONT AUDIO +
O	FC94-15 RH FRONT AUDIO -
O	FC94-16 RH FRONT AUDIO +
I	FC94-17 DIMMER CONTROLLED ILLUMINATION: PWM, 80Hz, GROUND = 0% DUTY CYCLE, B+ = 100% DUTY CYCLE
I	FC94-18 STEERING WHEEL SWITCHES: STEPPED RESISTANCE
O	FC94-19 D2B NETWORK WAKE-UP
D2	FC108-1 D2B NETWORK TRANSMIT
D2	FC108-2 D2B NETWORK RECEIVE

NOTE: Refer to the Appendix at the rear of this book for Network Messages.

Fig. 15.1

COMPONENTS

Component	Connector(s)	Connector Description	Location
AM / FM ANTENNA AMPLIFIER	CA220 CA221	NOT AVAILABLE 3-WAY / BLACK	LH C POST, ADJACENT TO REAR WINDOW
AUDIO UNIT	FC94 FC96 FC108	20-WAY / BLACK ANTENNA CONNECTOR FIBER OPTIC CONNECTOR	CENTER CONSOLE
CD AUTOCHANGER	CA267 RA2	3-WAY / BLACK FIBER OPTIC CONNECTOR	LUGGAGE COMPARTMENT, LH REAR
HEATED REAR WINDOW	CA20	2-WAY / GREY	CONNECTOR LOCATED BELOW PARCEL SHELF, LH SIDE
SPEAKER – LH FRONT	DT3 (LHD) PT2 (RHD)	2-WAY / BLACK 2-WAY / BLACK	LH FRONT DOOR
SPEAKER – LH REAR	CA80	2-WAY / BLACK	LH REAR DOOR
SPEAKER – RH FRONT	DT3 (RHD) PT2 (LHD)	2-WAY / BLACK 2-WAY / BLACK	RH FRONT DOOR
SPEAKER – RH REAR	CA92	2-WAY / BLACK	LH REAR DOOR
STEERING WHEEL AUDIO SWITCHES	SQ1	4-WAY / BLACK	STEERING WHEEL

HARNESS IN-LINE CONNECTORS

Connector	Connector Description / Location	Location
DT8	14-WAY / GREY / CABIN HARNESS TO DRIVER DOOR TRIM HARNESS	DRIVER DOOR
FC10	14-WAY / GREEN / FASCIA HARNESS TO FRONT HARNESS	BEHIND INSTRUMENT PANEL, RH SIDE
FC117	10-WAY / BLACK / STEERING WHEEL CASSETTE	STEERING COLUMN
FC23	10-WAY / GREY / CABIN HARNESS TO FASCIA HARNESS	BEHIND INSTRUMENT PANEL, LH SIDE
FC33	16-WAY / GREEN / CABIN HARNESS TO FASCIA HARNESS	BEHIND INSTRUMENT PANEL, RH SIDE
FC5	2-WAY / BLACK / FASCIA HARNESS (ANTENNA) TO CABIN HARNESS (ANTENNA)	BEHIND CENTER CONSOLE
PI41	42-WAY / BLACK / ENGINE HARNESS TO VEHICLE HARNESSES	ENGINE COMPARTMENT, BULKHEAD, PASSENGER SIDE
PT1	14-WAY / GREY / CABIN HARNESS TO PASSENGER DOOR TRIM HARNESS	PASSENGER DOOR

GROUND

Ground	Location
CA157	LUGGAGE COMPARTMENT, LH SIDE AFT OF WHEEL ARCH
FC38	UNDER CENTER OF INSTRUMENT PANEL, ON TRANSMISSION TUNNEL

FOR CONTROL MODULE PIN-OUT INFORMATION, UNFOLD PAGE TO LEFT.

The following abbreviations are used to represent values for Control Module Pin-Out data

I	Input	PG	Power Ground	C	CAN Network	D	Serial and Encoded Data
O	Output	SS	Sensor / Signal Supply V	S	SCP Network	V	Voltage (DC)
B+	Battery Voltage	SG	Sensor / Signal Ground	D2	D2B Network	PWM	Pulse Width Modulated

CAUTION: The information on this data page is furnished to aid the user in understanding circuit operation. THIS INFORMATION SHOULD BE USED FOR REFERENCE ONLY.

NOTE: The values listed are approximately those that can be expected at the control module connector pins with all circuit connections made and all components connected and fitted.

Refer to the front of this book for detailed information and illustrations regarding the location and identification of harnesses, relays, fuses, grounds, control modules and control module pins.

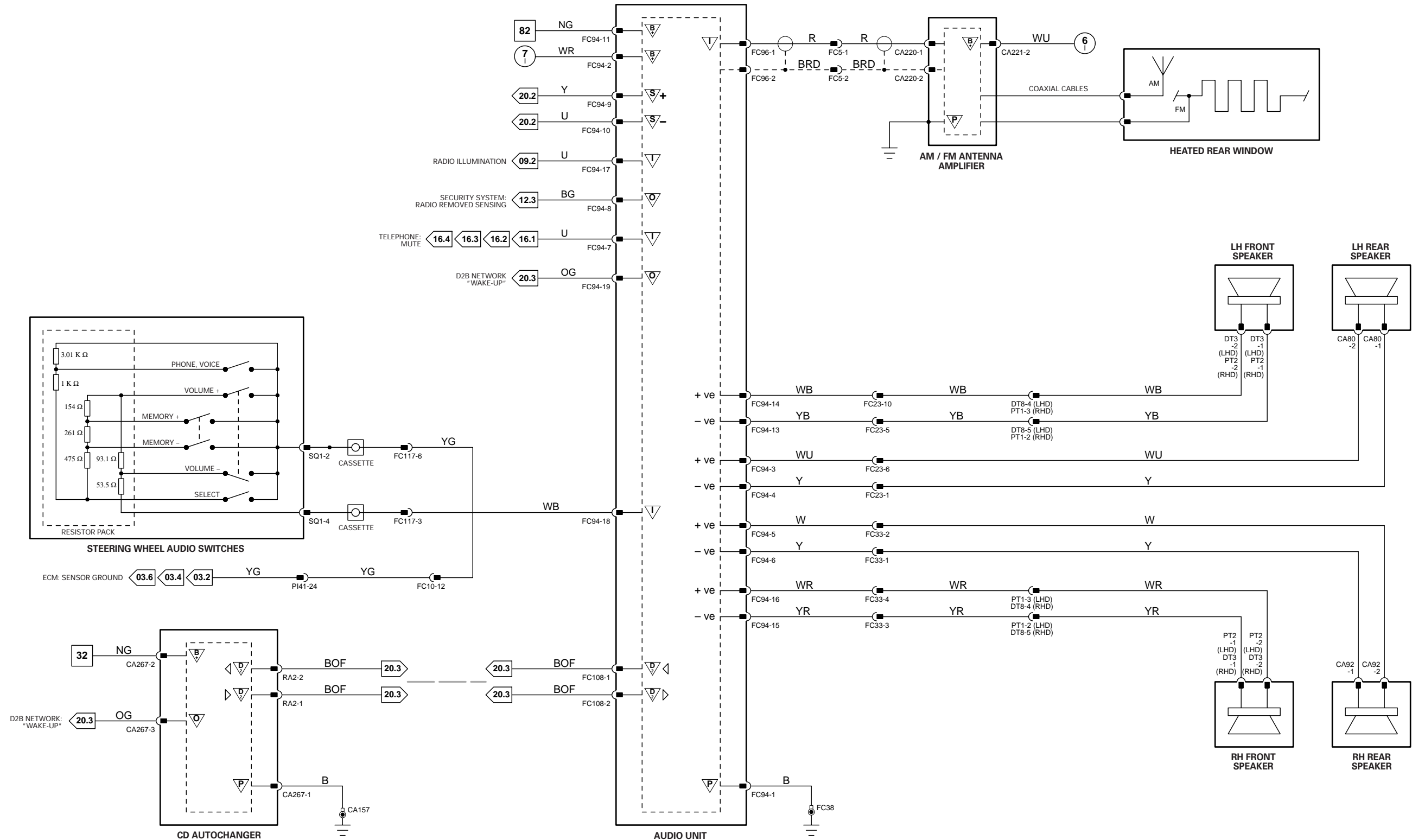

CONTROL MODULE PIN-OUT INFORMATION

Audio Unit – Premium

Pin	Description and Characteristic
PG	FC94-1 POWER GROUND: GROUND
B+	FC94-2 IGNITION SWITCHED POWER SUPPLY (I): B+
I	FC94-7 TELEPHONE MUTE SIGNAL
O	FC94-8 SECURITY SYSTEM GROUND SENSING: GROUND WHEN AUDIO UNIT INSTALLED
S	FC94-9 SCP +
S	FC94-10 SCP -
B+	FC94-11 BATTERY POWER SUPPLY: B+
I	FC94-17 DIMMER CONTROLLED ILLUMINATION: PWM, 80Hz, GROUND = 0% DUTY CYCLE, B+ = 100% DUTY CYCLE
I	FC94-18 STEERING WHEEL SWITCHES: STEPPED RESISTANCE
O	FC94-19 D2B NETWORK WAKE-UP
D2	FC108-1 D2B NETWORK TRANSMIT
D2	FC108-2 D2B NETWORK RECEIVE

NOTE: Refer to the Appendix at the rear of this book for Network Messages.

Fig. 15.2

COMPONENTS

Component	Connector(s)	Connector Description	Location
AM / FM ANTENNA AMPLIFIER	CA220 CA221	NOT AVAILABLE 3-WAY / BLACK	LH C POST, ADJACENT TO REAR WINDOW
AUDIO UNIT	FC94 FC96 FC108	20-WAY / BLACK ANTENNA CONNECTOR FIBER OPTIC CONNECTOR	CENTER CONSOLE
CD AUTOCHANGER	CA267 RA2	3-WAY / BLACK FIBER OPTIC CONNECTOR	LUGGAGE COMPARTMENT, LH REAR
HEATED REAR WINDOW	CA20	2-WAY / GREY	CONNECTOR LOCATED BELOW PARCEL SHELF, LH SIDE
POWER AMPLIFIER	CA263 CA264 RA6	POWER AMPLIFIER CONNECTOR POWER AMPLIFIER CONNECTOR FIBER OPTIC CONNECTOR	LUGGAGE COMPARTMENT, LH REAR
SPEAKER – LH FRONT	CA276	4-WAY / WHITE	LH FRONT DOOR
SPEAKER – LH REAR	CA277	4-WAY / WHITE	LH REAR DOOR
SPEAKER – RH FRONT	CA275	4-WAY / WHITE	RH FRONT DOOR
SPEAKER – RH REAR	CA278	4-WAY / WHITE	RH REAR DOOR
STEERING WHEEL AUDIO SWITCHES	SQ1	4-WAY / BLACK	STEERING WHEEL
SUBWOOFER – LH	CA6	2-WAY / WHITE	PARCEL SHELF, LH SIDE
SUBWOOFER – RH	CA5	2-WAY / WHITE	PARCEL SHELF, RH SIDE

HARNESS IN-LINE CONNECTORS

Connector	Connector Description / Location	Location
FC5	2-WAY / BLACK / FASCIA HARNESS (ANTENNA) TO CABIN HARNESS (ANTENNA)	BEHIND CENTER CONSOLE
FC10	14-WAY / GREEN / FASCIA HARNESS TO FRONT HARNESS	BEHIND INSTRUMENT PANEL, RH SIDE
FC117	10-WAY / BLACK / STEERING WHEEL CASSETTE	STEERING COLUMN
PI41	42-WAY / BLACK / ENGINE HARNESS TO VEHICLE HARNESSES	ENGINE COMPARTMENT, BULKHEAD, PASSENGER SIDE

GROUND

Ground	Location
CA157	LUGGAGE COMPARTMENT, LH SIDE AFT OF WHEEL ARCH
FC38	UNDER CENTER OF INSTRUMENT PANEL, ON TRANSMISSION TUNNEL

FOR CONTROL MODULE PIN-OUT INFORMATION, UNFOLD PAGE TO LEFT.

The following abbreviations are used to represent values for Control Module Pin-Out data

I	Input	PG	Power Ground	C	CAN Network	D	Serial and Encoded Data
O	Output	SS	Sensor / Signal Supply V	S	SCP Network	V	Voltage (DC)
B+	Battery Voltage	SG	Sensor / Signal Ground	D2	D2B Network	PWM	Pulse Width Modulated

CAUTION: The information on this data page is furnished to aid the user in understanding circuit operation. THIS INFORMATION SHOULD BE USED FOR REFERENCE ONLY.

NOTE: The values listed are approximately those that can be expected at the control module connector pins with all circuit connections made and all components connected and fitted.

Refer to the front of this book for detailed information and illustrations regarding the location and identification of harnesses, relays, fuses, grounds, control modules and control module pins.

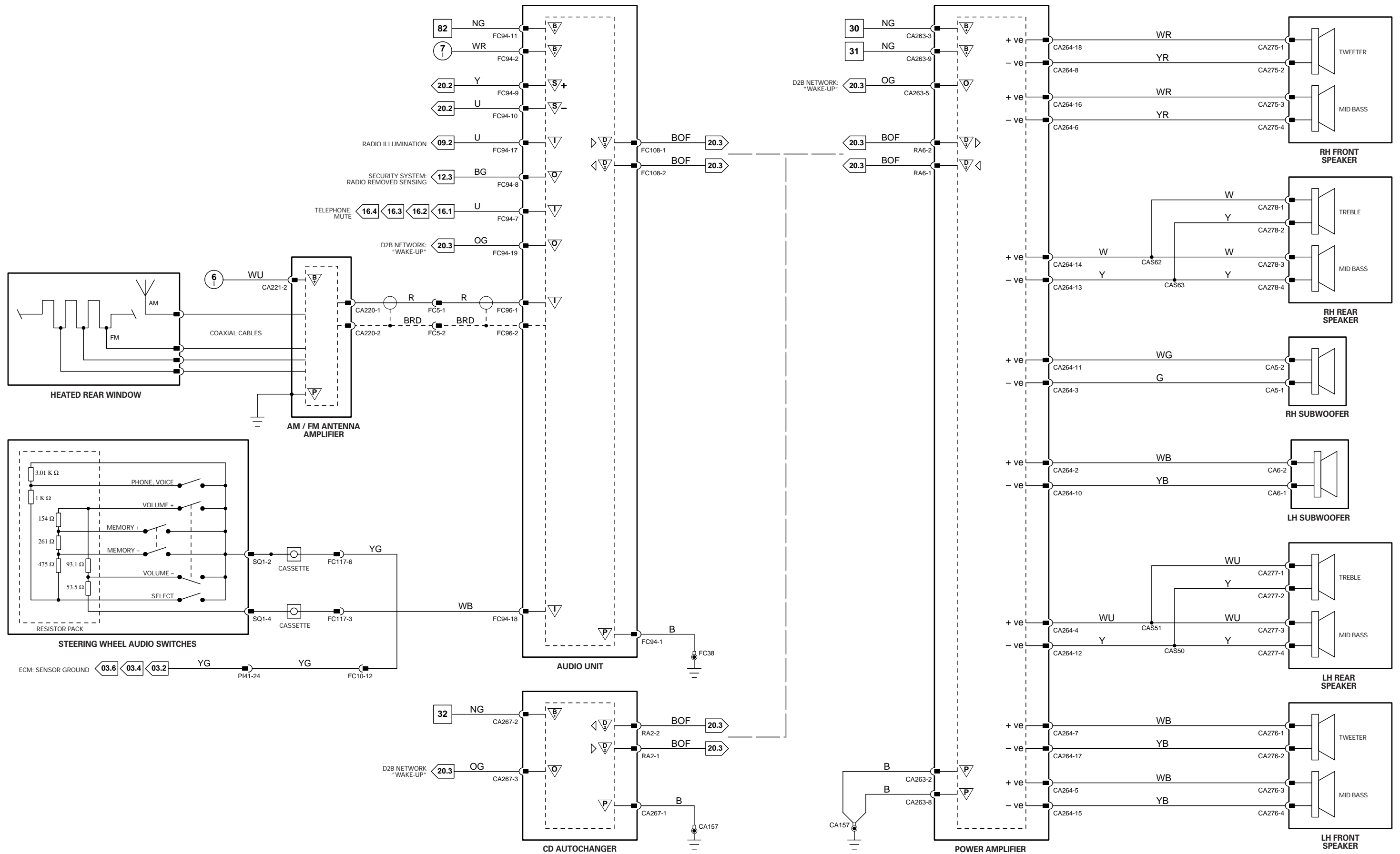

CONTROL MODULE PIN-OUT INFORMATION

Audio Unit

Pin	Description and Characteristic
I FC94-7	TELEPHONE MUTE SIGNAL

Cellular Phone Control Module

Pin	Description and Characteristic
O CA261-1	PHONE BATTERY CHARGING SUPPLY
O CA261-3	PHONE ON /OFF (RESPONSE TO INCOMING AUDIO)
O CA261-4	MUTE COMMAND
- CA261-7	COMPUTER
- CA261-8	COMPUTER
PG CA261-9	POWER GROUND: GROUND
SG CA261-11	MICROPHONE SHIELD: GROUND
B+ CA261-12	BATTERY POWER SUPPLY: B+
B+ CA261-13	BATTERY POWER SUPPLY: B+
B+ CA261-14	IGNITION SWITCHED POWER SUPPLY (I): B+
I CA261-15	JAGUAR NET ASSISTANCE REQUEST
O CA261-16	JAGUAR NET ASSISTANCE CALL INDICATOR
I CA261-17	MICROPHONE +
I CA261-18	MICROPHONE -
D CA261-20	TELEPHONE SERIAL COMMUNICATIONS DATA
D CA261-22	TELEPHONE SERIAL COMMUNICATIONS DATA
I CA261-23	D2B NETWORK WAKE-UP
- CA261-24	COMPUTER
I CA261-25	POWER GROUND: GROUND
I CA261-26	TELEPHONE LOGIC GROUND: GROUND
I CA261-29	IGNITION SWITCHED POWER SUPPLY (II): B+
I CA261-30	AIRBAG DEPLOYED SIGNAL
I CA261-31	JAGUAR NET INFORMATION REQUEST
O CA261-32	JAGUAR NET INFORMATION CALL INDICATOR
D2 RA3-1	D2B NETWORK RECEIVE
D2 RA3-2	D2B NETWORK TRANSMIT

Fig. 16.1

COMPONENTS

Component	Connector(s)	Connector Description	Location
AUDIO UNIT	FC94 FC96 FC108	20-WAY / BLACK ANTENNA CONNECTOR FIBER OPTIC CONNECTOR	CENTER CONSOLE
CELLULAR PHONE CONTROL MODULE	CA209 CA210 CA211 CA261 RA3	2-WAY / BLACK 2-WAY / BLACK 2-WAY / BLACK 32-WAY / BLACK FIBER OPTIC CONNECTOR	LUGGAGE COMPARTMENT, LH REAR
HAND SET RECEIVER	CA213 CA216 CA217	2-WAY / BLACK 10-WAY / GREY 2-WAY / BLACK	CENTER CONSOLE
JaguarNet GPS ANTENNA	CA214	2-WAY / BLACK	PARCEL SHELF, RH SIDE
NAVIGATION CONTROL MODULE	CA176 CA257 CA258 CA259 RA5	2-WAY / GREY 26-WAY / NATURAL 20-WAY / BLACK 12-WAY / BLACK FIBER OPTIC CONNECTOR	LUGGAGE COMPARTMENT, LH REAR
ROOF CONSOLE	CA250	22-WAY / BLACK	ROOF HEADLINER
TELEMATICS DISPLAY	FC92	22-WAY / BLACK	CENTER CONSOLE
TELEPHONE ANTENNA (BUMPER)	BR8	ANTENNA CONNECTOR	REAR BUMPER, LH SIDE
TELEPHONE ANTENNA (WITH JaguarNet)	CA212	ANTENNA CONNECTOR	REAR WINDOW

HARNESS IN-LINE CONNECTORS

Connector	Connector Description / Location	Location
BR9	2-WAY / BLACK / CABIN HARNESS (ANTENNA) TO BUMPER HARNESS (ANTENNA)	LUGGAGE COMPARTMENT, LH SIDE
CA300	22-WAY / GREY / CABIN HARNESS IN-LINE CONNECTOR WHEN VOICE ACTIVATION CONTROL MODULE IS NOT FITTED	LUGGAGE COMPARTMENT, LH REAR
FC23	10-WAY / GREY / CABIN HARNESS TO FASCIA HARNESS	BEHIND INSTRUMENT PANEL, LH SIDE

GROUNDS

Ground	Location
CA50	RH LOWER 'A' POST, BELOW PRIMARY JUNCTION FUSE BOX
CA157	LUGGAGE COMPARTMENT, LH SIDE AFT OF WHEEL ARCH

FOR CONTROL MODULE PIN-OUT INFORMATION, UNFOLD PAGE TO LEFT.

The following abbreviations are used to represent values for Control Module Pin-Out data

I	Input	PG	Power Ground	C	CAN Network	D	Serial and Encoded Data
O	Output	SS	Sensor / Signal Supply V	S	SCP Network	V	Voltage (DC)
B+	Battery Voltage	SG	Sensor / Signal Ground	D2	D2B Network	PWM	Pulse Width Modulated

CAUTION: The information on this data page is furnished to aid the user in understanding circuit operation. THIS INFORMATION SHOULD BE USED FOR REFERENCE ONLY.

NOTE: The values listed are approximately those that can be expected at the control module connector pins with all circuit connections made and all components connected and fitted.

Refer to the front of this book for detailed information and illustrations regarding the location and identification of harnesses, relays, fuses, grounds, control modules and control module pins.

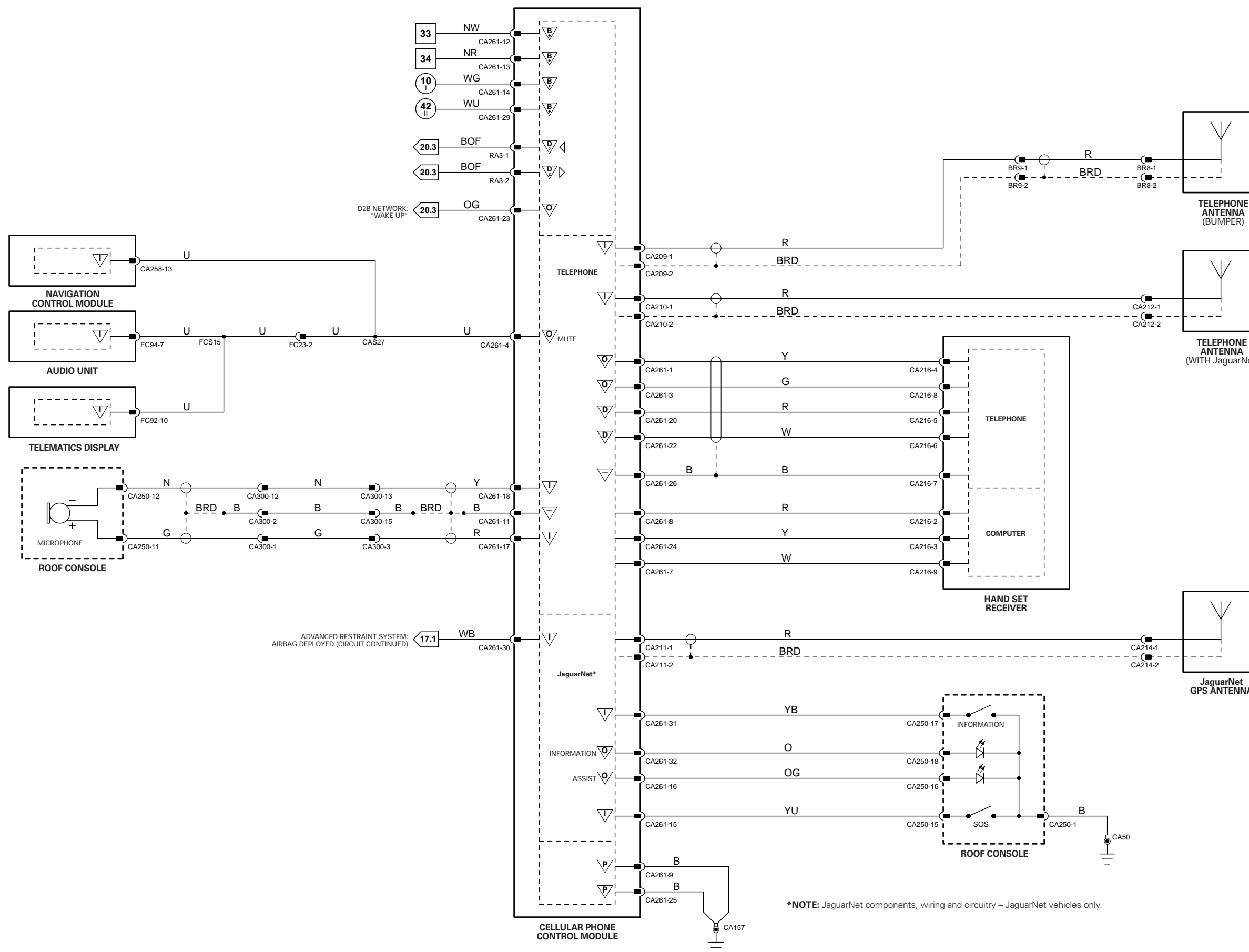

*NOTE: JaguarNet components, wiring and circuitry - JaguarNet vehicles only.

CONTROL MODULE PIN-OUT INFORMATION

Audio Unit

Pin	Description and Characteristic
I FC94-7	TELEPHONE MUTE SIGNAL

Cellular Phone Control Module

Pin	Description and Characteristic
O CA261-1	PHONE BATTERY CHARGING SUPPLY
O CA261-2	HANDS FREE AUDIO TO PHONE
O CA261-3	PHONE ON /OFF (RESPONSE TO INCOMING AUDIO)
O CA261-4	MUTE COMMAND
I CA261-5	MANUAL TEST DATA
I CA261-6	PHONE BATTERY VOLTAGE
PG CA261-9	POWER GROUND: GROUND
SG CA261-10	ANALOG GROUND: GROUND
SG CA261-11	MICROPHONE SHIELD: GROUND
B+ CA261-12	BATTERY POWER SUPPLY: B+
B+ CA261-13	BATTERY POWER SUPPLY: B+
B+ CA261-14	IGNITION SWITCHED POWER SUPPLY (I): B+
I CA261-15	JAGUAR NET ASSISTANCE REQUEST
O CA261-16	JAGUAR NET ASSISTANCE CALL INDICATOR
I CA261-17	MICROPHONE +
I CA261-18	MICROPHONE -
D CA261-20	TELEPHONE SERIAL COMMUNICATIONS DATA
D CA261-21	TELEPHONE SERIAL COMMUNICATIONS DATA
D CA261-22	TELEPHONE SERIAL COMMUNICATIONS DATA
I CA261-23	D2B NETWORK WAKE-UP
I CA261-25	POWER GROUND: GROUND
I CA261-26	TELEPHONE LOGIC GROUND: GROUND
I CA261-29	IGNITION SWITCHED POWER SUPPLY (II): B+
I CA261-30	AIRBAG DEPLOYED SIGNAL
I CA261-31	JAGUAR NET INFORMATION REQUEST
O CA261-32	JAGUAR NET INFORMATION CALL INDICATOR
D2 RA3-1	D2B NETWORK RECEIVE
D2 RA3-2	D2B NETWORK TRANSMIT

Fig. 16.2

COMPONENTS

Component	Connector(s)	Connector Description	Location
AUDIO UNIT	FC94 FC96 FC108	20-WAY / BLACK ANTENNA CONNECTOR FIBER OPTIC CONNECTOR	CENTER CONSOLE
CELLULAR PHONE CONTROL MODULE	CA209 CA210 CA211 CA261 RA3	2-WAY / BLACK 2-WAY / BLACK 2-WAY / BLACK 32-WAY / BLACK FIBER OPTIC CONNECTOR	LUGGAGE COMPARTMENT, LH REAR
HAND SET RECEIVER	CA213 CA216 CA217	2-WAY / BLACK 10-WAY / GREY 2-WAY / BLACK	CENTER CONSOLE
JaguarNet GPS ANTENNA	CA214	2-WAY / BLACK	PARCEL SHELF, RH SIDE
NAVIGATION CONTROL MODULE	CA176 CA257 CA258 CA259 RA5	2-WAY / GREY 26-WAY / NATURAL 20-WAY / BLACK 12-WAY / BLACK FIBER OPTIC CONNECTOR	LUGGAGE COMPARTMENT, LH REAR
ROOF CONSOLE	CA250	22-WAY / BLACK	ROOF HEADLINER
TELEMATICS DISPLAY	FC92	22-WAY / BLACK	CENTER CONSOLE
TELEPHONE ANTENNA (BUMPER)	BR8	ANTENNA CONNECTOR	REAR BUMPER, LH SIDE
TELEPHONE ANTENNA (WITH JaguarNet)	CA212	ANTENNA CONNECTOR	REAR WINDOW

HARNESS IN-LINE CONNECTORS

Connector	Connector Description / Location	Location
BR9	2-WAY / BLACK / CABIN HARNESS (ANTENNA) TO BUMPER HARNESS (ANTENNA)	LUGGAGE COMPARTMENT, LH SIDE
CA300	22-WAY / GREY / CABIN HARNESS IN-LINE CONNECTOR WHEN VOICE ACTIVATION CONTROL MODULE IS NOT FITTED	LUGGAGE COMPARTMENT, LH REAR
FC23	10-WAY / GREY / CABIN HARNESS TO FASCIA HARNESS	BEHIND INSTRUMENT PANEL, LH SIDE

GROUNDS

Ground	Location
CA50	RH LOWER 'A' POST, BELOW PRIMARY JUNCTION FUSE BOX
CA157	LUGGAGE COMPARTMENT, LH SIDE AFT OF WHEEL ARCH

FOR CONTROL MODULE PIN-OUT INFORMATION, UNFOLD PAGE TO LEFT.

The following abbreviations are used to represent values for Control Module Pin-Out data

I	Input	PG	Power Ground	C	CAN Network	D	Serial and Encoded Data
O	Output	SS	Sensor / Signal Supply V	S	SCP Network	V	Voltage (DC)
B+	Battery Voltage	SG	Sensor / Signal Ground	D2	D2B Network	PWM	Pulse Width Modulated

CAUTION: The information on this data page is furnished to aid the user in understanding circuit operation. THIS INFORMATION SHOULD BE USED FOR REFERENCE ONLY.

NOTE: The values listed are approximately those that can be expected at the control module connector pins with all circuit connections made and all components connected and fitted.

Refer to the front of this book for detailed information and illustrations regarding the location and identification of harnesses, relays, fuses, grounds, control modules and control module pins.

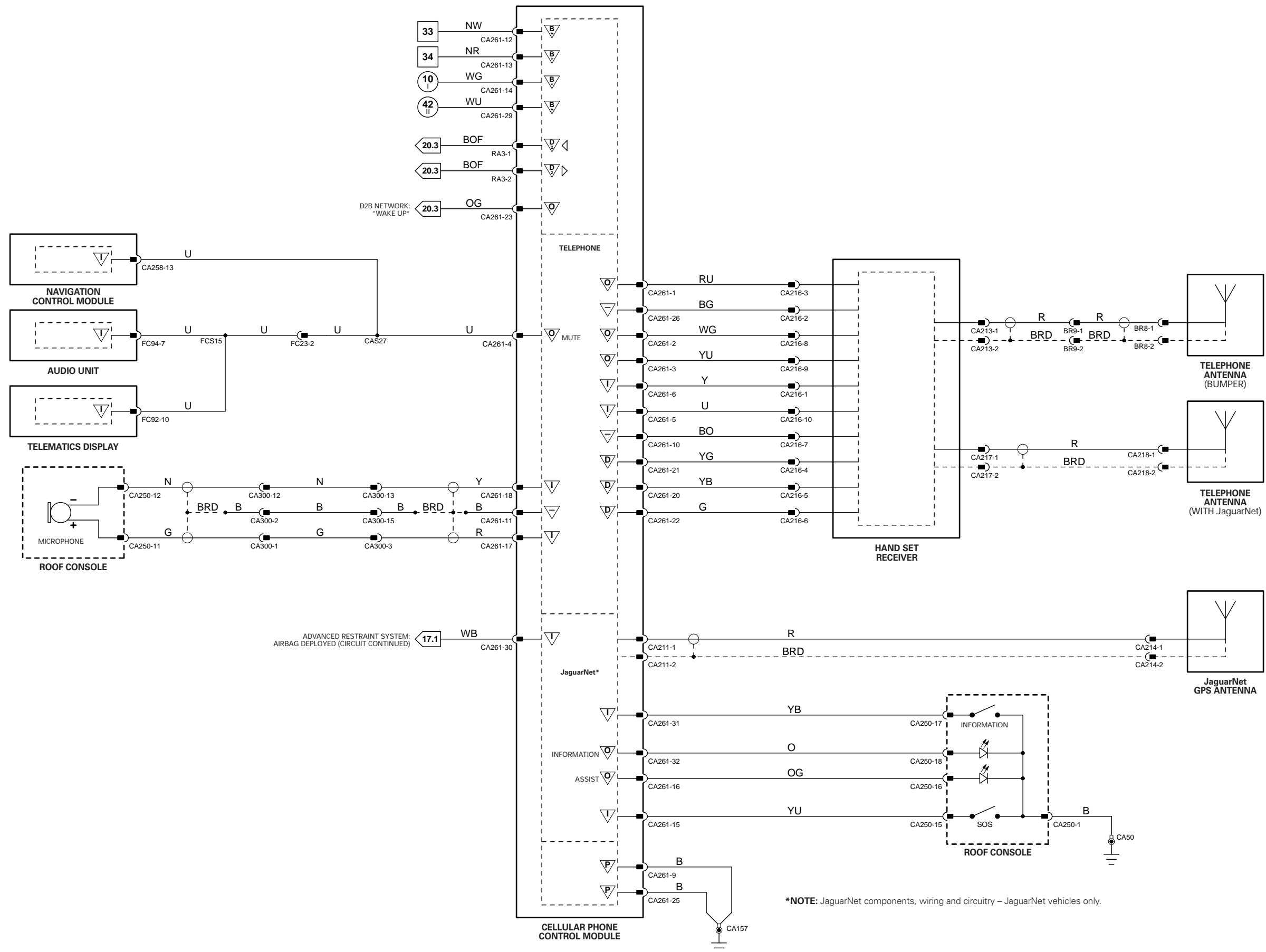

*NOTE: JaguarNet components, wiring and circuitry – JaguarNet vehicles only.

CONTROL MODULE PIN-OUT INFORMATION

Audio Unit

Pin	Description and Characteristic
I FC94-7	TELEPHONE MUTE SIGNAL
I FC94-18	STEERING WHEEL SWITCHES: STEPPED RESISTANCE
D2 FC108-1	D2B NETWORK TRANSMIT
D2 FC108-2	D2B NETWORK RECEIVE

Cellular Phone Control Module

Pin	Description and Characteristic
O CA261-1	PHONE BATTERY CHARGING SUPPLY
O CA261-3	PHONE ON /OFF (RESPONSE TO INCOMING AUDIO)
O CA261-4	MUTE COMMAND
- CA261-7	COMPUTER
- CA261-8	COMPUTER
PG CA261-9	POWER GROUND: GROUND
SG CA261-10	ANALOG GROUND: GROUND
SG CA261-11	MICROPHONE SHIELD: GROUND
B+ CA261-12	BATTERY POWER SUPPLY: B+
B+ CA261-13	BATTERY POWER SUPPLY: B+
B+ CA261-14	IGNITION SWITCHED POWER SUPPLY (I): B+
I CA261-15	JAGUAR NET ASSISTANCE REQUEST
O CA261-16	JAGUAR NET ASSISTANCE CALL INDICATOR
I CA261-17	MICROPHONE +
I CA261-18	MICROPHONE -
D CA261-20	TELEPHONE SERIAL COMMUNICATIONS DATA
D CA261-22	TELEPHONE SERIAL COMMUNICATIONS DATA
I CA261-23	D2B NETWORK WAKE-UP
- CA261-24	COMPUTER
I CA261-25	POWER GROUND: GROUND
I CA261-26	TELEPHONE LOGIC GROUND: GROUND
I CA261-29	IGNITION SWITCHED POWER SUPPLY (II): B+
I CA261-30	AIRBAG DEPLOYED SIGNAL
I CA261-31	JAGUAR NET INFORMATION REQUEST
O CA261-32	JAGUAR NET INFORMATION CALL INDICATOR
D2 RA3-1	D2B NETWORK RECEIVE
D2 RA3-2	D2B NETWORK TRANSMIT

Voice Activation Control Module

Pin	Description and Characteristic
I CA300-1	MICROPHONE +
SG CA300-2	MICROPHONE SHIELD
- CA300-3	-
B+ CA300-6	IGNITION SWITCHED POWER SUPPLY (I) (START / RUN STATUS)
B+ CA300-8	IGNITION SWITCHED POWER SUPPLY (I)
PG CA300-11	POWER GROUND
I CA300-12	MICROPHONE -
- CA300-13	-
O CA300-14	D2B NETWORK WAKE UP
- CA300-15	-
B+ CA300-22	BATTERY POWER SUPPLY
D2 RA4-1	D2B NETWORK TRANSMIT
D2 RA4-2	D2B NETWORK RECEIVE

The following abbreviations are used to represent values for Control Module Pin-Out data

I	Input	PG	Power Ground	C	CAN Network	D	Serial and Encoded Data
O	Output	SS	Sensor / Signal Supply V	S	SCP Network	V	Voltage (DC)
B+	Battery Voltage	SG	Sensor / Signal Ground	D2	D2B Network	PWM	Pulse Width Modulated

CAUTION: The information on this data page is furnished to aid the user in understanding circuit operation. THIS INFORMATION SHOULD BE USED FOR REFERENCE ONLY.

NOTE: The values listed are approximately those that can be expected at the control module connector pins with all circuit connections made and all components connected and fitted.

Fig. 16.3

COMPONENTS

Component	Connector(s)	Connector Description	Location
AUDIO UNIT	FC94 FC96 FC108	20-WAY / BLACK ANTENNA CONNECTOR FIBER OPTIC CONNECTOR	CENTER CONSOLE
CELLULAR PHONE CONTROL MODULE	CA209 CA210 CA211 CA261 RA3	2-WAY / BLACK 2-WAY / BLACK 2-WAY / BLACK 32-WAY / BLACK FIBER OPTIC CONNECTOR	LUGGAGE COMPARTMENT, LH REAR
HAND SET RECEIVER	CA213 CA216 CA217	2-WAY / BLACK 10-WAY / GREY 2-WAY / BLACK	CENTER CONSOLE
JaguarNet GPS ANTENNA	CA214	2-WAY / BLACK	PARCEL SHELF, RH SIDE
NAVIGATION CONTROL MODULE	CA176 CA257 CA258 CA259 RA5	2-WAY / GREY 26-WAY / NATURAL 20-WAY / BLACK 12-WAY / BLACK FIBER OPTIC CONNECTOR	LUGGAGE COMPARTMENT, LH REAR
ROOF CONSOLE	CA250	22-WAY / BLACK	ROOF HEADLINER
STEERING WHEEL AUDIO SWITCHES	SQ1	4-WAY / BLACK	STEERING WHEEL
TELEMATICS DISPLAY	FC92	22-WAY / BLACK	CENTER CONSOLE
TELEPHONE ANTENNA (BUMPER)	BR8	ANTENNA CONNECTOR	REAR BUMPER, LH SIDE
TELEPHONE ANTENNA (WITH JaguarNet)	CA212	ANTENNA CONNECTOR	REAR WINDOW
VOICE ACTIVATION CONTROL MODULE	CA300 RA4	22-WAY / GREY FIBER OPTIC CONNECTOR	LUGGAGE COMPARTMENT, LH REAR

HARNES IN-LINE CONNECTORS

Connector	Connector Description / Location	Location
BR9	2-WAY / BLACK / CABIN HARNES (ANTENNA) TO BUMPER HARNES (ANTENNA)	LUGGAGE COMPARTMENT, LH SIDE
FC10	14-WAY / GREEN / FASCIA HARNES TO FRONT HARNES	BEHIND INSTRUMENT PANEL, RH SIDE
FC23	10-WAY / GREY / CABIN HARNES TO FASCIA HARNES	BEHIND INSTRUMENT PANEL, LH SIDE
FC117	10-WAY / BLACK / STEERING WHEEL CASSETTE	STEERING COLUMN
PI41	42-WAY / BLACK / ENGINE HARNES TO VEHICLE HARNESSES	ENGINE COMPARTMENT, BULKHEAD, PASSENGER SIDE

GROUND S

Ground	Location
CA50	RH LOWER 'A' POST, BELOW PRIMARY JUNCTION FUSE BOX
CA157	LUGGAGE COMPARTMENT, LH SIDE AFT OF WHEEL ARCH

FOR CONTROL MODULE PIN-OUT INFORMATION, UNFOLD PAGE TO LEFT.

Refer to the front of this book for detailed information and illustrations regarding the location and identification of harnesses, relays, fuses, grounds, control modules and control module pins.

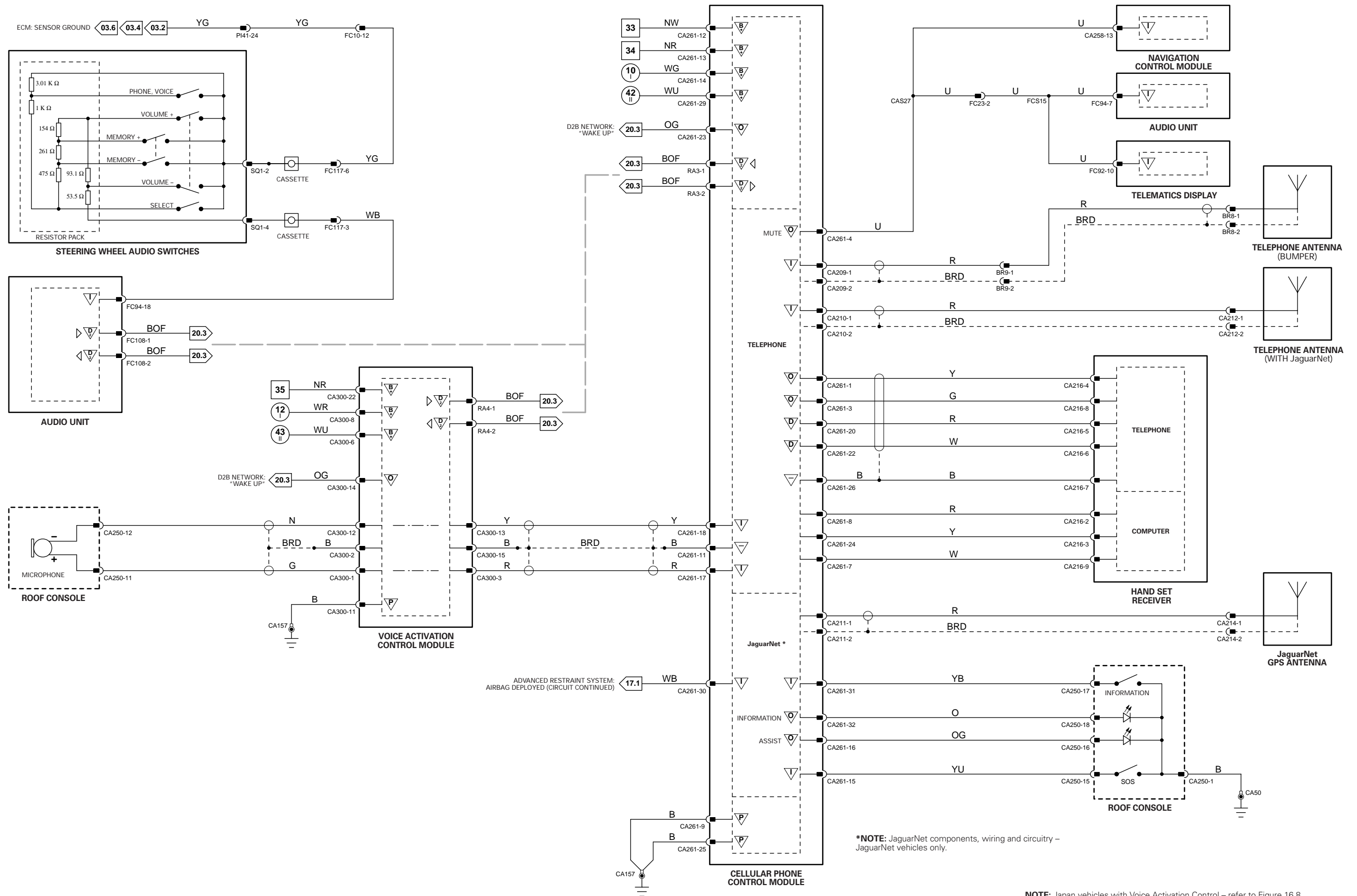

NOTE: Japan vehicles with Voice Activation Control – refer to Figure 16.8.

CONTROL MODULE PIN-OUT INFORMATION

Audio Unit

Pin	Description and Characteristic
I FC94-7	TELEPHONE MUTE SIGNAL
I FC94-18	STEERING WHEEL SWITCHES: STEPPED RESISTANCE
D2 FC108-1	D2B NETWORK TRANSMIT
D2 FC108-2	D2B NETWORK RECEIVE

Cellular Phone Control Module

Pin	Description and Characteristic
O CA261-1	PHONE BATTERY CHARGING SUPPLY
O CA261-2	HANDS FREE AUDIO TO PHONE
O CA261-3	PHONE ON /OFF (RESPONSE TO INCOMING AUDIO)
O CA261-4	MUTE COMMAND
I CA261-5	MANUAL TEST DATA
I CA261-6	PHONE BATTERY VOLTAGE
PG CA261-9	POWER GROUND: GROUND
SG CA261-10	ANALOG GROUND: GROUND
SG CA261-11	MICROPHONE SHIELD: GROUND
B+ CA261-12	BATTERY POWER SUPPLY: B+
B+ CA261-13	BATTERY POWER SUPPLY: B+
B+ CA261-14	IGNITION SWITCHED POWER SUPPLY (I): B+
I CA261-15	JAGUAR NET ASSISTANCE REQUEST
O CA261-16	JAGUAR NET ASSISTANCE CALL INDICATOR
I CA261-17	MICROPHONE +
I CA261-18	MICROPHONE -
D CA261-20	TELEPHONE SERIAL COMMUNICATIONS DATA
D CA261-21	TELEPHONE SERIAL COMMUNICATIONS DATA
D CA261-22	TELEPHONE SERIAL COMMUNICATIONS DATA
I CA261-23	D2B NETWORK WAKE-UP
I CA261-25	POWER GROUND: GROUND
I CA261-26	TELEPHONE LOGIC GROUND: GROUND
I CA261-29	IGNITION SWITCHED POWER SUPPLY (II): B+
I CA261-30	AIRBAG DEPLOYED SIGNAL
I CA261-31	JAGUAR NET INFORMATION REQUEST
O CA261-32	JAGUAR NET INFORMATION CALL INDICATOR
D2 RA3-1	D2B NETWORK RECEIVE
D2 RA3-2	D2B NETWORK TRANSMIT

Voice Activation Control Module

Pin	Description and Characteristic
I CA300-1	MICROPHONE +
SG CA300-2	MICROPHONE SHIELD
- CA300-3	-
B+ CA300-6	IGNITION SWITCHED POWER SUPPLY (II) (START / RUN STATUS)
B+ CA300-8	IGNITION SWITCHED POWER SUPPLY (I)
PG CA300-11	POWER GROUND
I CA300-12	MICROPHONE -
- CA300-13	-
O CA300-14	D2B NETWORK WAKE UP
- CA300-15	-
B+ CA300-22	BATTERY POWER SUPPLY
D2 RA4-1	D2B NETWORK TRANSMIT
D2 RA4-2	D2B NETWORK RECEIVE

The following abbreviations are used to represent values for Control Module Pin-Out data

I	Input	PG	Power Ground	C	CAN Network	D	Serial and Encoded Data
O	Output	SS	Sensor / Signal Supply V	S	SCP Network	V	Voltage (DC)
B+	Battery Voltage	SG	Sensor / Signal Ground	D2	D2B Network	PWM	Pulse Width Modulated

CAUTION: The information on this data page is furnished to aid the user in understanding circuit operation. THIS INFORMATION SHOULD BE USED FOR REFERENCE ONLY.

NOTE: The values listed are approximately those that can be expected at the control module connector pins with all circuit connections made and all components connected and fitted.

Fig. 16.4

COMPONENTS

Component	Connector(s)	Connector Description	Location
AUDIO UNIT	FC94 FC96 FC108	20-WAY / BLACK ANTENNA CONNECTOR FIBER OPTIC CONNECTOR	CENTER CONSOLE
CELLULAR PHONE CONTROL MODULE	CA209 CA210 CA211 CA261 RA3	2-WAY / BLACK 2-WAY / BLACK 2-WAY / BLACK 32-WAY / BLACK FIBER OPTIC CONNECTOR	LUGGAGE COMPARTMENT, LH REAR
HAND SET RECEIVER	CA213 CA216 CA217	2-WAY / BLACK 10-WAY / GREY 2-WAY / BLACK	CENTER CONSOLE
JaguarNet GPS ANTENNA	CA214	2-WAY / BLACK	PARCEL SHELF, RH SIDE
NAVIGATION CONTROL MODULE	CA176 CA257 CA258 CA259 RA5	2-WAY / GREY 26-WAY / NATURAL 20-WAY / BLACK 12-WAY / BLACK FIBER OPTIC CONNECTOR	LUGGAGE COMPARTMENT, LH REAR
ROOF CONSOLE	CA250	22-WAY / BLACK	ROOF HEADLINER
STEERING WHEEL AUDIO SWITCHES	SQ1	4-WAY / BLACK	STEERING WHEEL
TELEMATICS DISPLAY	FC92	22-WAY / BLACK	CENTER CONSOLE
TELEPHONE ANTENNA (BUMPER)	BR8	ANTENNA CONNECTOR	REAR BUMPER, LH SIDE
TELEPHONE ANTENNA (WITH JaguarNet)	CA212	ANTENNA CONNECTOR	REAR WINDOW
VOICE ACTIVATION CONTROL MODULE	CA300 RA4	22-WAY / GREY FIBER OPTIC CONNECTOR	LUGGAGE COMPARTMENT, LH REAR

HARNESS IN-LINE CONNECTORS

Connector	Connector Description / Location	Location
BR9	2-WAY / BLACK / CABIN HARNESS (ANTENNA) TO BUMPER HARNESS (ANTENNA)	LUGGAGE COMPARTMENT, LH SIDE
FC10	14-WAY / GREEN / FASCIA HARNESS TO FRONT HARNESS	BEHIND INSTRUMENT PANEL, RH SIDE
FC23	10-WAY / GREY / CABIN HARNESS TO FASCIA HARNESS	BEHIND INSTRUMENT PANEL, LH SIDE
FC117	10-WAY / BLACK / STEERING WHEEL CASSETTE	STEERING COLUMN
PI41	42-WAY / BLACK / ENGINE HARNESS TO VEHICLE HARNESSES	ENGINE COMPARTMENT, BULKHEAD, PASSENGER SIDE

GROUND

Ground	Location
CA50	RH LOWER 'A' POST, BELOW PRIMARY JUNCTION FUSE BOX
CA157	LUGGAGE COMPARTMENT, LH SIDE AFT OF WHEEL ARCH

FOR CONTROL MODULE PIN-OUT INFORMATION, UNFOLD PAGE TO LEFT.

Refer to the front of this book for detailed information and illustrations regarding the location and identification of harnesses, relays, fuses, grounds, control modules and control module pins.

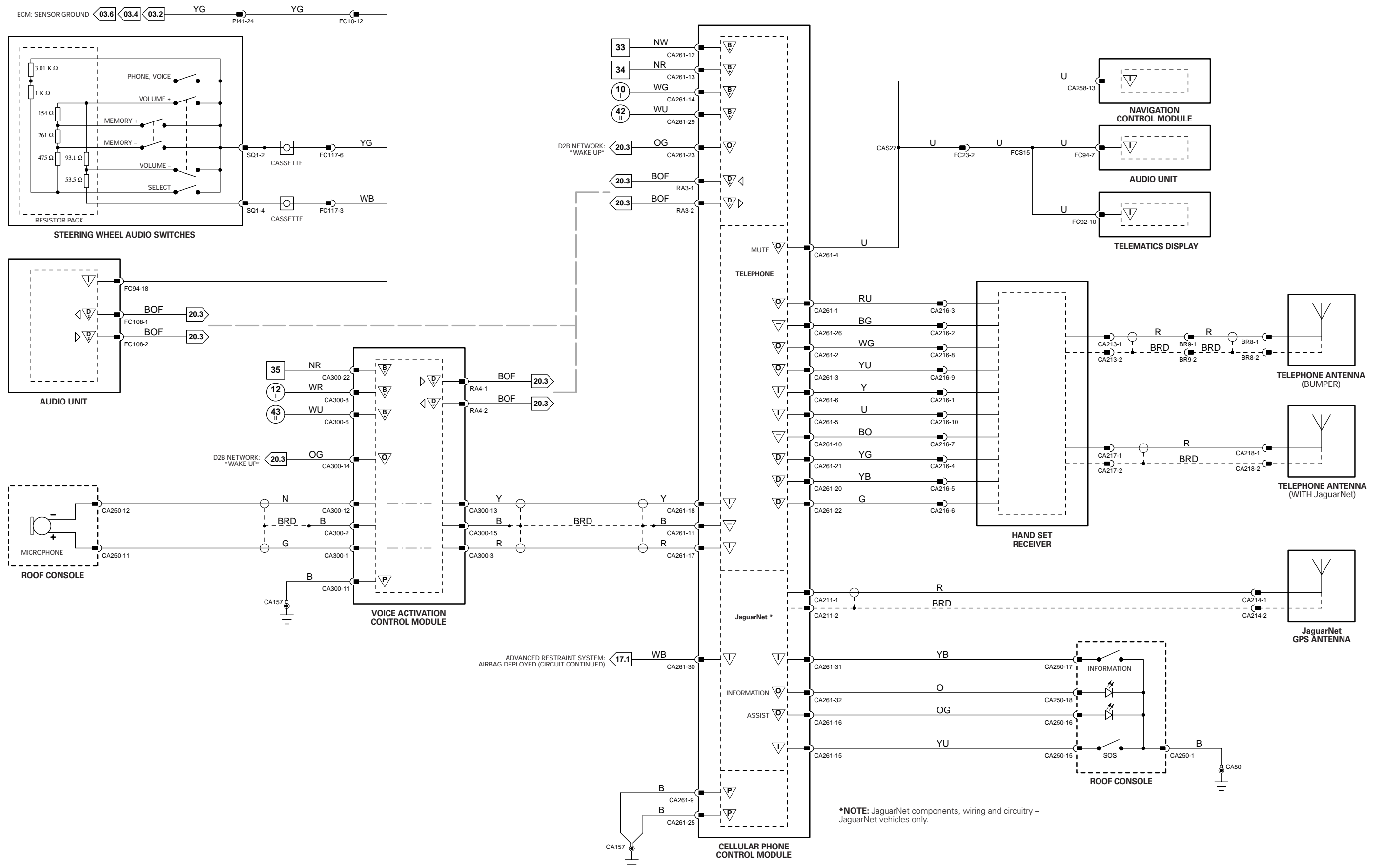

CONTROL MODULE PIN-OUT INFORMATION

Audio Unit

Pin	Description and Characteristic
I FC94-18	STEERING WHEEL SWITCHES: STEPPED RESISTANCE
D2 FC108-1	D2B NETWORK TRANSMIT
D2 FC108-2	D2B NETWORK RECEIVE

Voice Activation Control Module

Pin	Description and Characteristic
I CA300-1	MICROPHONE +
SG CA300-2	MICROPHONE SHIELD
B+ CA300-6	IGNITION SWITCHED POWER SUPPLY (I) (START / RUN STATUS)
B+ CA300-8	IGNITION SWITCHED POWER SUPPLY (I)
PG CA300-11	POWER GROUND
I CA300-12	MICROPHONE -
O CA300-14	D2B NETWORK WAKE UP
B+ CA300-22	BATTERY POWER SUPPLY
D2 RA4-1	D2B NETWORK TRANSMIT
D2 RA4-2	D2B NETWORK RECEIVE

Fig. 16.5

COMPONENTS

Component	Connector(s)	Connector Description	Location
AUDIO UNIT	FC94 FC96 FC108	20-WAY / BLACK ANTENNA CONNECTOR FIBER OPTIC CONNECTOR	CENTER CONSOLE
ROOF CONSOLE	CA250	22-WAY / BLACK	ROOF HEADLINER
STEERING WHEEL AUDIO SWITCHES	SQ1	4-WAY / BLACK	STEERING WHEEL
VOICE ACTIVATION CONTROL MODULE	CA300 RA4	22-WAY / GREY FIBER OPTIC CONNECTOR	LUGGAGE COMPARTMENT, LH REAR

HARNESS IN-LINE CONNECTORS

Connector	Connector Description / Location	Location
FC10	14-WAY / GREEN / FASCIA HARNESS TO FRONT HARNESS	BEHIND INSTRUMENT PANEL, RH SIDE
FC117	10-WAY / BLACK / STEERING WHEEL CASSETTE	STEERING COLUMN
PI41	42-WAY / BLACK / ENGINE HARNESS TO VEHICLE HARNESSES	ENGINE COMPARTMENT, BULKHEAD, PASSENGER SIDE

GROUND

Ground	Location
CA157	LUGGAGE COMPARTMENT, LH SIDE AFT OF WHEEL ARCH

FOR CONTROL MODULE PIN-OUT INFORMATION, UNFOLD PAGE TO LEFT.

The following abbreviations are used to represent values for Control Module Pin-Out data

I	Input	PG	Power Ground	C	CAN Network	D	Serial and Encoded Data
O	Output	SS	Sensor / Signal Supply V	S	SCP Network	V	Voltage (DC)
B+	Battery Voltage	SG	Sensor / Signal Ground	D2	D2B Network	PWM	Pulse Width Modulated

CAUTION: The information on this data page is furnished to aid the user in understanding circuit operation. THIS INFORMATION SHOULD BE USED FOR REFERENCE ONLY.

NOTE: The values listed are approximately those that can be expected at the control module connector pins with all circuit connections made and all components connected and fitted.

Refer to the front of this book for detailed information and illustrations regarding the location and identification of harnesses, relays, fuses, grounds, control modules and control module pins.

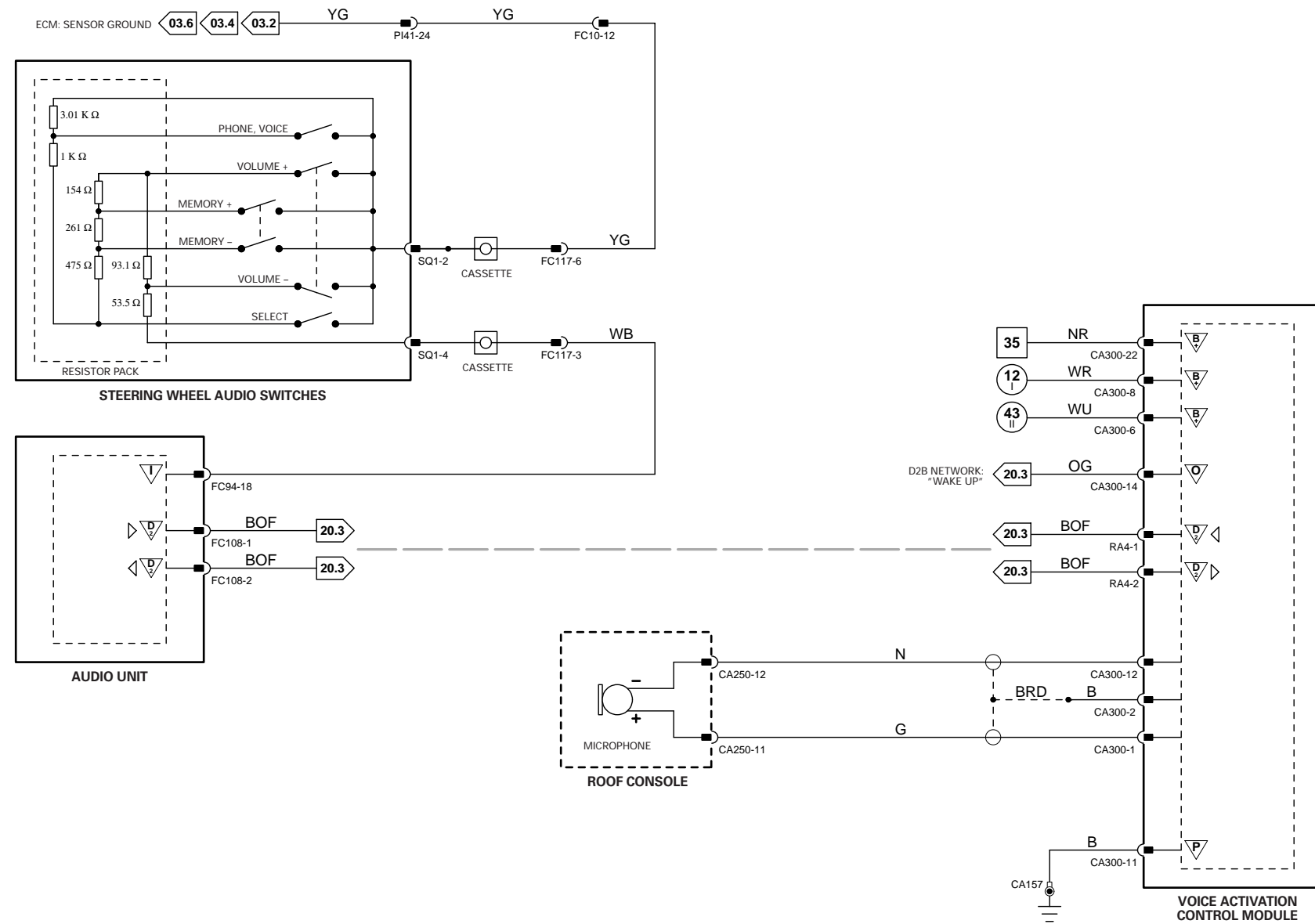

NOTE: Japan vehicles with Voice Activation Control – refer to Figure 16.8.

Fig. 16.6**COMPONENTS**

Component	Connector(s)	Connector Description	Location
NAVIGATION CONTROL MODULE	CA176 CA257 CA258 CA259 RA5	2-WAY / GREY 26-WAY / NATURAL 20-WAY / BLACK 12-WAY / BLACK FIBER OPTIC CONNECTOR	LUGGAGE COMPARTMENT, LH REAR
NAVIGATION GPS ANTENNA	CA175	2-WAY / GREY	PARCEL SHELF, CENTER
NAVIGATION SCREEN AND TELEMATICS DISPLAY	FC92 FC102 FC103 FC104 FC105	22-WAY / BLACK 2-WAY GREY 2-WAY GREY 2-WAY GREY 2-WAY GREY	CENTER CONSOLE

HARNESS IN-LINE CONNECTORS

Connector	Connector Description / Location	Location
FC19	16-WAY / GREEN / CABIN HARNESS TO FASCIA HARNESS	BEHIND INSTRUMENT PANEL, LH SIDE

GROUNDS

Ground	Location
FC38	UNDER CENTER OF INSTRUMENT PANEL, ON TRANSMISSION TUNNEL

Refer to the front of this book for detailed information and illustrations regarding the location and identification of harnesses, relays, fuses, grounds, control modules and control module pins.

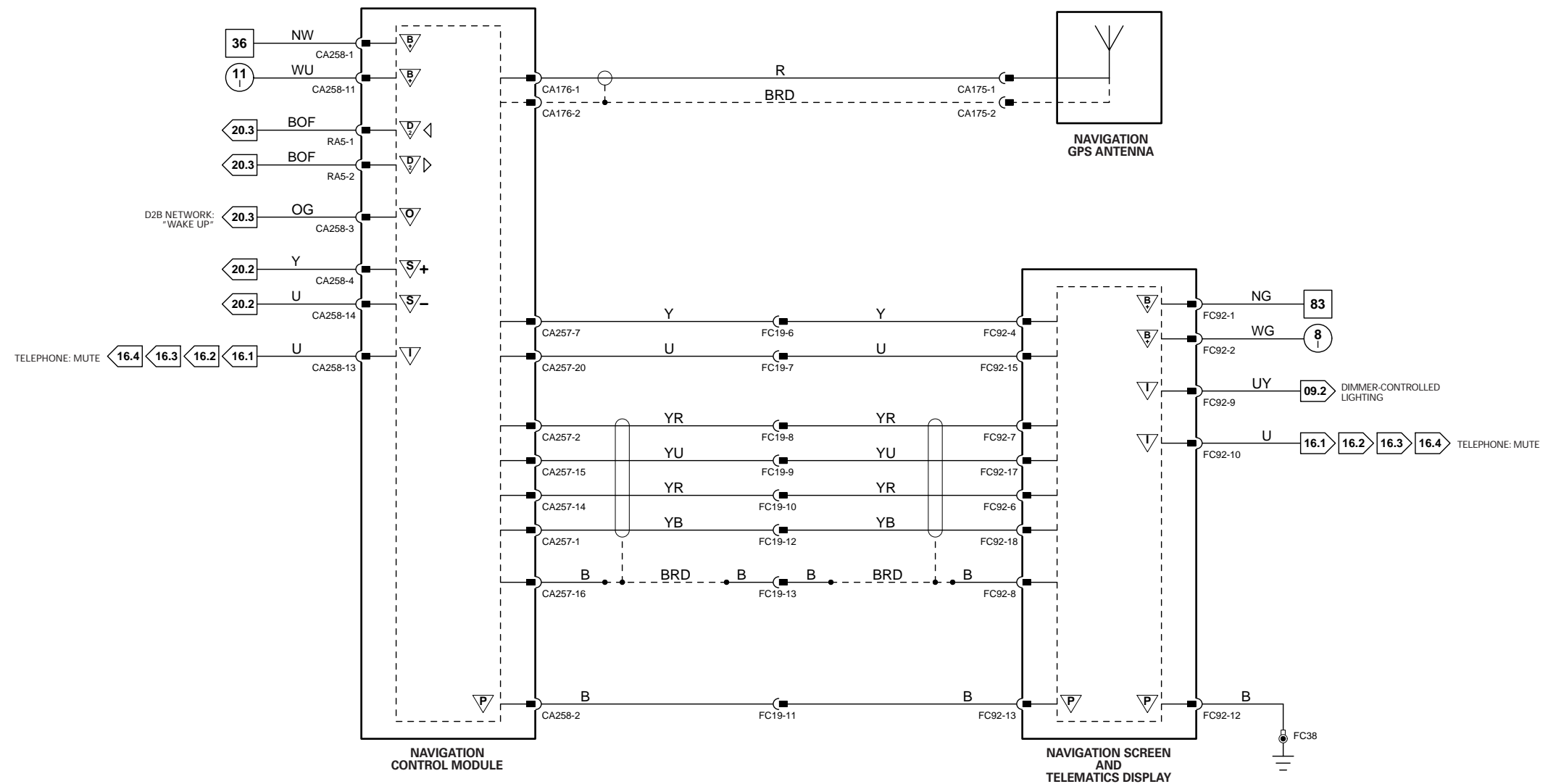

Fig. 16.7**COMPONENTS**

Component	Connector(s)	Connector Description	Location
NAVIGATION CONTROL MODULE	CA176 CA257 CA258 CA259 RA5	2-WAY / GREY 26-WAY / NATURAL 20-WAY / BLACK 12-WAY / BLACK FIBER OPTIC CONNECTOR	LUGGAGE COMPARTMENT, LH REAR
NAVIGATION GPS ANTENNA	CA175	2-WAY / GREY	PARCEL SHELF, CENTER
NAVIGATION SCREEN AND TELEMATICS DISPLAY	FC92 FC102 FC103 FC104 FC105	22-WAY / BLACK 2-WAY GREY 2-WAY GREY 2-WAY GREY 2-WAY GREY	CENTER CONSOLE
TV ANTENNA AND AMPLIFIER 1	CA198	2-WAY / GREY	PARCEL SHELF
TV ANTENNA AND AMPLIFIER 2	CA200	2-WAY / GREY	PARCEL SHELF
TV ANTENNA AND AMPLIFIER 3	CA202	2-WAY / GREY	PARCEL SHELF
TV ANTENNA AND AMPLIFIER 4	CA204	2-WAY / GREY	PARCEL SHELF

HARNESS IN-LINE CONNECTORS

Connector	Connector Description / Location	Location
FC19	16-WAY / GREEN / CABIN HARNESS TO FASCIA HARNESS	BEHIND INSTRUMENT PANEL, LH SIDE
FC98	4-WAY / BLACK / FASCIA HARNESS (ANTENNA) TO CABIN HARNESS (ANTENNA)	BEHIND INSTRUMENT PANEL, LH SIDE
FC99	4-WAY / BLACK / FASCIA HARNESS (ANTENNA) TO CABIN HARNESS (ANTENNA)	BEHIND INSTRUMENT PANEL, RH SIDE
FC122	6-WAY / BLACK / FASCIA HARNESS TO SEAT HARNESSES	UNDER CENTER CONSOLE

GROUNDS

Ground	Location
FC38	UNDER CENTER OF INSTRUMENT PANEL, ON TRANSMISSION TUNNEL

Refer to the front of this book for detailed information and illustrations regarding the location and identification of harnesses, relays, fuses, grounds, control modules and control module pins.

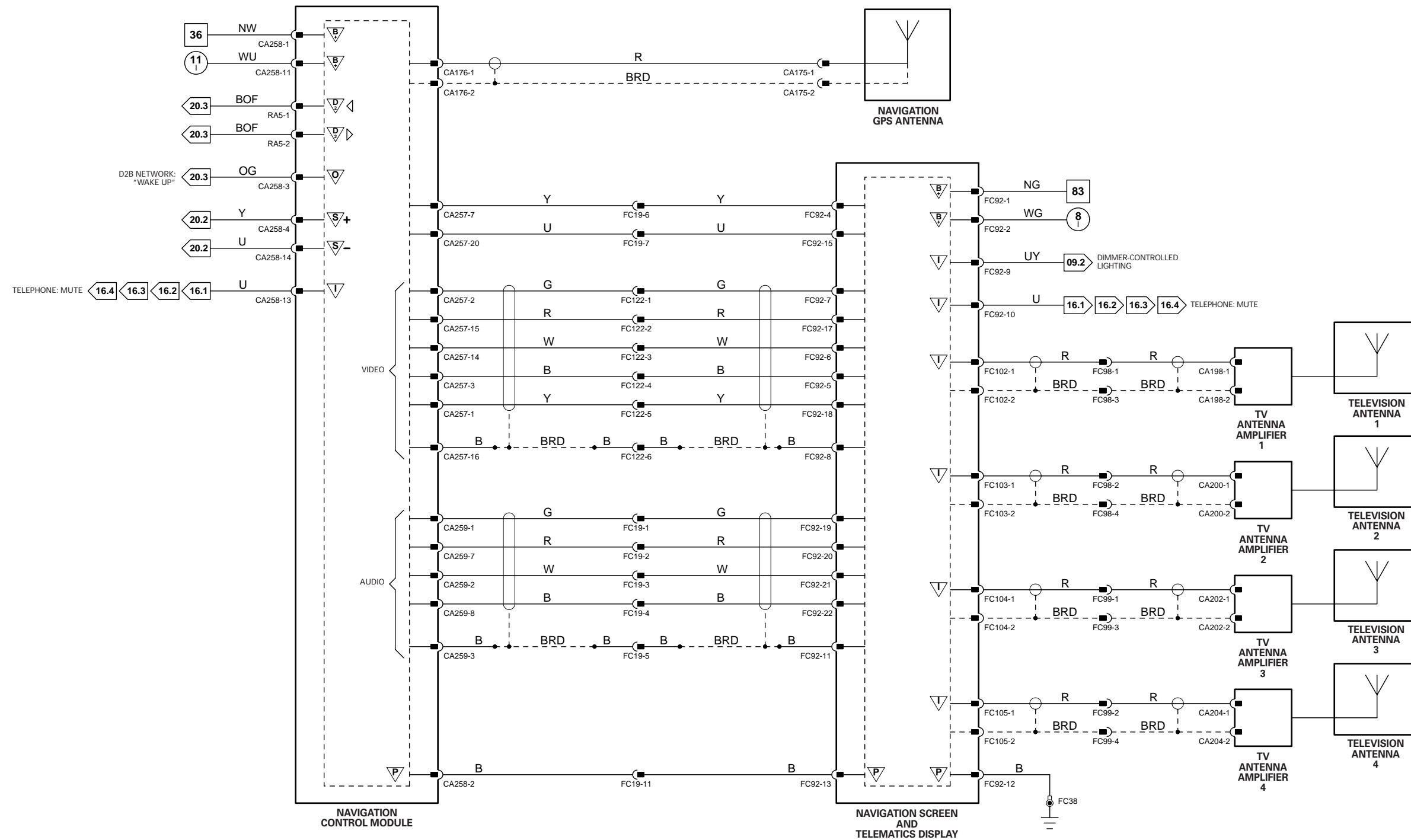

Fig. 16.8**COMPONENTS**

Component	Connector(s)	Connector Description	Location
NAVIGATION CONTROL MODULE	CA176 CA257 CA258 CA259 RA5	2-WAY / GREY 26-WAY / NATURAL 20-WAY / BLACK 12-WAY / BLACK FIBER OPTIC CONNECTOR	LUGGAGE COMPARTMENT, LH REAR
NAVIGATION GPS ANTENNA	CA175	2-WAY / GREY	PARCEL SHELF, CENTER
NAVIGATION SCREEN AND TELEMATICS DISPLAY	FC92 FC102 FC103 FC104 FC105	22-WAY / BLACK 2-WAY GREY 2-WAY GREY 2-WAY GREY 2-WAY GREY	CENTER CONSOLE
OOF CONSOLE	CA250	22-WAY / BLACK	ROOF HEADLINER
TV ANTENNA AND AMPLIFIER 1	CA198	2-WAY / GREY	PARCEL SHELF
TV ANTENNA AND AMPLIFIER 2	CA200	2-WAY / GREY	PARCEL SHELF
TV ANTENNA AND AMPLIFIER 3	CA202	2-WAY / GREY	PARCEL SHELF
TV ANTENNA AND AMPLIFIER 4	CA204	2-WAY / GREY	PARCEL SHELF
VEHICLE INFORMATION ANTENNA	CA208	ANTENNA CONNECTOR	PARCEL SHELF
VEHICLE INFORMATION CONTROL MODULE	CA207 CA268 CA273	ANTENNA CONNECTOR ANTENNA CONNECTOR 10-WAY / BLACK	LUGGAGE COMPARTMENT, LH SIDE
VEHICLE INFORMATION SENSOR	FC95	ANTENNA CONNECTOR	INSTRUMENT PANEL

HARNESS IN-LINE CONNECTORS

Connector	Connector Description / Location	Location
FC19	16-WAY / GREEN / CABIN HARNESS TO FASCIA HARNESS	BEHIND INSTRUMENT PANEL, LH SIDE
FC93	2-WAY / BLACK / FASCIA HARNESS (ANTENNA) TO CABIN HARNESS (ANTENNA)	BEHIND INSTRUMENT PANEL
FC98	4-WAY / BLACK / FASCIA HARNESS (ANTENNA) TO CABIN HARNESS (ANTENNA)	BEHIND INSTRUMENT PANEL, LH SIDE
FC99	4-WAY / BLACK / FASCIA HARNESS (ANTENNA) TO CABIN HARNESS (ANTENNA)	BEHIND INSTRUMENT PANEL, RH SIDE
FC122	6-WAY / BLACK / FASCIA HARNESS TO SEAT HARNESSES	UNDER CENTER CONSOLE

GROUNDS

Ground	Location
CA157	LUGGAGE COMPARTMENT, LH SIDE AFT OF WHEEL ARCH
FC38	UNDER CENTER OF INSTRUMENT PANEL, ON TRANSMISSION TUNNEL

Refer to the front of this book for detailed information and illustrations regarding the location and identification of harnesses, relays, fuses, grounds, control modules and control module pins.

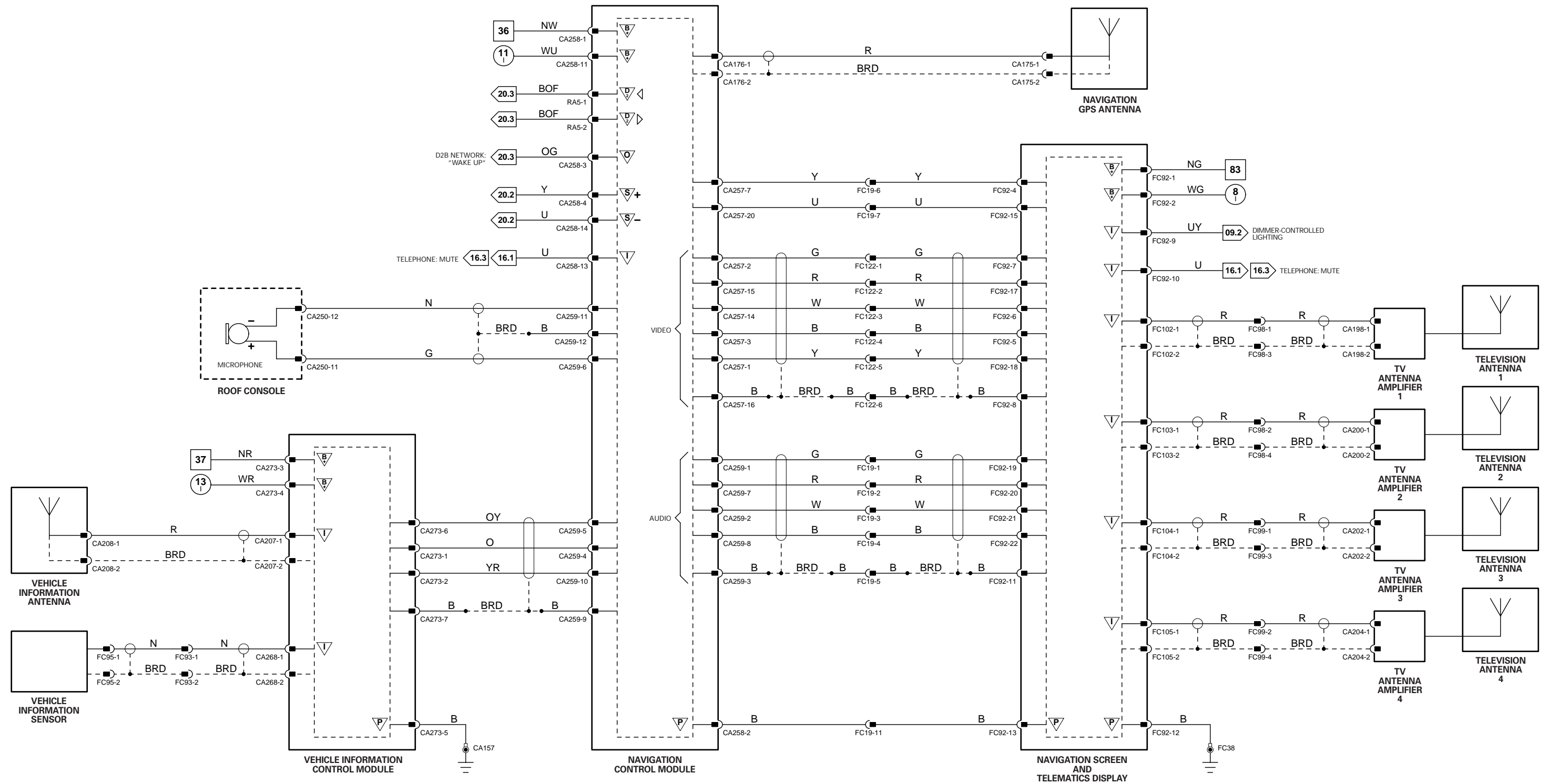

Fig. 17.1

COMPONENTS

Component	Connector(s)	Connector Description	Location
AIRBAG IGNITER – DRIVER, CURTAIN	CA226	2-WAY / YELLOW	HEADLINER, DRIVER SIDE
AIRBAG IGNITER – DRIVER, SIDE	DB4	2-WAY / YELLOW	DRIVER SEAT, SEAT BACK
AIRBAG IGNITER – PASSENGER, CURTAIN	CA288	2-WAY / YELLOW	HEADLINER, PASSENGER SIDE
AIRBAG IGNITER – PASSENGER, SIDE	PB4	2-WAY / YELLOW	PASSENGER SEAT, SEAT BACK
AIRBAG IGNITERS – DRIVER DUAL	SW11 SW12	2-WAY / BLACK 2-WAY / BLACK	STEERING WHEEL
DRIVER SEAT POSITION SWITCH	DM41	2-WAY / BLACK	DRIVER SEAT TRACK, LH SIDE
IMPACT SENSOR – DRIVER REAR SIDE	CA230	2-WAY / BLACK	LH 'D' POST
IMPACT SENSOR – DRIVER SIDE	CA22	2-WAY / BLACK	LH 'B/C' POST
IMPACT SENSOR – FRONT	FH102	2-WAY / BLACK	FRONT CROSS MEMBER, CENTER
IMPACT SENSOR – PASSENGER REAR SIDE	CA246	2-WAY / BLACK	RH 'D' POST
IMPACT SENSOR – PASSENGER SIDE	CA58	2-WAY / BLACK	RH 'B/C' POST
RESTRAINTS CONTROL MODULE	CA114 CA232	24-WAY / BLACK 40-WAY / BLACK	TRANSMISSION TUNNEL, UNDER CENTER CONSOLE
SEAT BELT PRETENSIONER IGNITER – CENTER REAR	CA224	2-WAY / YELLOW	SEAT BELT RETRACTOR
SEAT BELT PRETENSIONER IGNITER – DRIVER	DM20	4-WAY / GREY	SEAT BELT BUCKLE
SEAT BELT PRETENSIONER IGNITER – DRIVER SIDE REAR	CA225	2-WAY / YELLOW	SEAT BELT RETRACTOR
SEAT BELT PRETENSIONER IGNITER – PASSENGER	PN15	4-WAY / GREY	SEAT BELT BUCKLE
SEAT BELT PRETENSIONER IGNITER – PASSENGER SIDE REAR	CA223	2-WAY / YELLOW	SEAT BELT RETRACTOR
SEAT BELT SWITCH – DRIVER	DM20	4-WAY / GREY	SEAT BELT BUCKLE
SEAT BELT SWITCH – PASSENGER	PN15	4-WAY / GREY	SEAT BELT BUCKLE

HARNES IN-LINE CONNECTORS

Connector	Connector Description / Location	Location
DM23	20-WAY / BLACK / CABIN HARNESS TO DRIVER SEAT HARNESS	UNDER DRIVER SEAT
DM40	4-WAY / GREY / DRIVER SEAT ADVANCED RESTRAINT SYSTEM IN-LINE CONNECTOR	UNDER DRIVER SEAT
FC42	4-WAY / GREY / CABIN HARNESS TO FASCIA HARNESS	BEHIND INSTRUMENT PANEL, DRIVER SIDE
FC117	10-WAY / BLACK / STEERING WHEEL CASSETTE	STEERING COLUMN
FH2	16-WAY / GREY / CABIN HARNESS TO FRONT HARNESS	RH 'A' POST, LOWER
PN24	20-WAY / BLACK / CABIN HARNESS TO PASSENGER SEAT HARNESS	UNDER PASSENGER SEAT
PN35	4-WAY / GREY / PASSENGER SEAT ADVANCED RESTRAINT SYSTEM IN-LINE CONNECTOR	UNDER PASSENGER SEAT
SW9	2-WAY / YELLOW / ADVANCED RESTRAINT SYSTEM / STEERING WHEEL CASSETTE	STEERING WHEEL
SW10	2-WAY / YELLOW / ADVANCED RESTRAINT SYSTEM / STEERING WHEEL CASSETTE	STEERING WHEEL

GROUND

Ground	Location
CA141	UNDER LH FRONT SEAT
CA154	UNDER RH FRONT SEAT

Refer to the front of this book for detailed information and illustrations regarding the location and identification of harnesses, relays, fuses, grounds, control modules and control module pins.

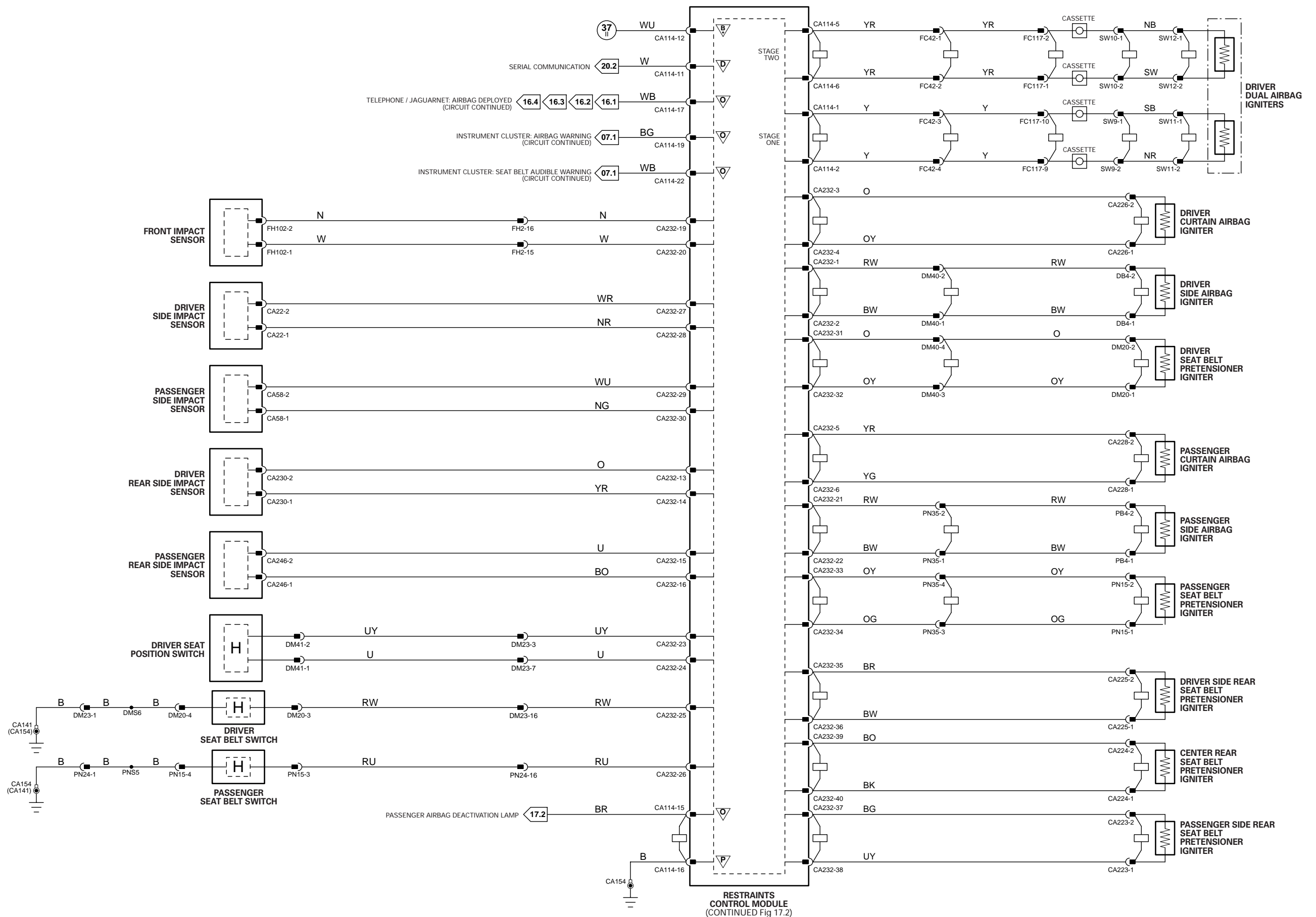

Fig. 17.2

COMPONENTS

Component	Connector(s)	Connector Description	Location
AIRBAG IGNITERS - PASSENGER DUAL	FC32 FC46	2-WAY / BROWN 2-WAY / BROWN	INSTRUMENT PANEL
OCCUPANCY SENSING CONTROL MODULE	PN38	26-WAY / WHITE	UNDER PASSENGER SEAT
PASSENGER AIRBAG DEACTIVATED INDICATOR LAMP	FC112	3-WAY / BLACK	PASSENGER AIRBAG "DOOR"
PASSENGER SEAT WEIGHT PRESSURE SENSOR	PN41	3-WAY / BLACK	PASSENGER SEAT
PASSENGER SEAT WEIGHT SENSING CONTROL MODULE	PN37	10-WAY / BLACK	UNDER PASSENGER SEAT
RESTRAINTS CONTROL MODULE	CA114 CA232	24-WAY / BLACK 40-WAY / BLACK	TRANSMISSION TUNNEL, UNDER CENTER CONSOLE
SPATIAL SENSOR - CENTER CONSOLE	FC3 (RHD) FC114 (LHD)	2-WAY / GREY 2-WAY / GREY	CENTER CONSOLE
SPATIAL SENSOR - HEADLINER REAR INNER	RF41	2-WAY / BLACK	HEADLINER, ABOVE FRONT PASSENGER
SPATIAL SENSOR - HEADLINER REAR OUTER	RF40	2-WAY / BLACK	HEADLINER, ABOVE FRONT PASSENGER
SPATIAL SENSOR - PASSENGER 'A' POST	CA251	2-WAY / BLACK	PASSENGER SIDE 'A' POST

HARNESS IN-LINE CONNECTORS

Connector	Connector Description / Location	Location
FC25	4-WAY / GREY / CABIN HARNESS TO FASCIA HARNESS	BEHIND INSTRUMENT PANEL, PASSENGER SIDE
FC33	16-WAY / GREEN / CABIN HARNESS TO FASCIA HARNESS	BEHIND INSTRUMENT PANEL, RH SIDE
PN24	20-WAY / BLACK / CABIN HARNESS TO PASSENGER SEAT HARNESS	UNDER PASSENGER SEAT
RF34	16-WAY / GREEN / CABIN HARNESS TO DOOR HARNESS	'D' POST, UNDER PARCEL SHELF

GROUND

Ground	Location
CA141	UNDER LH FRONT SEAT
CA154	UNDER RH FRONT SEAT

Refer to the front of this book for detailed information and illustrations regarding the location and identification of harnesses, relays, fuses, grounds, control modules and control module pins.

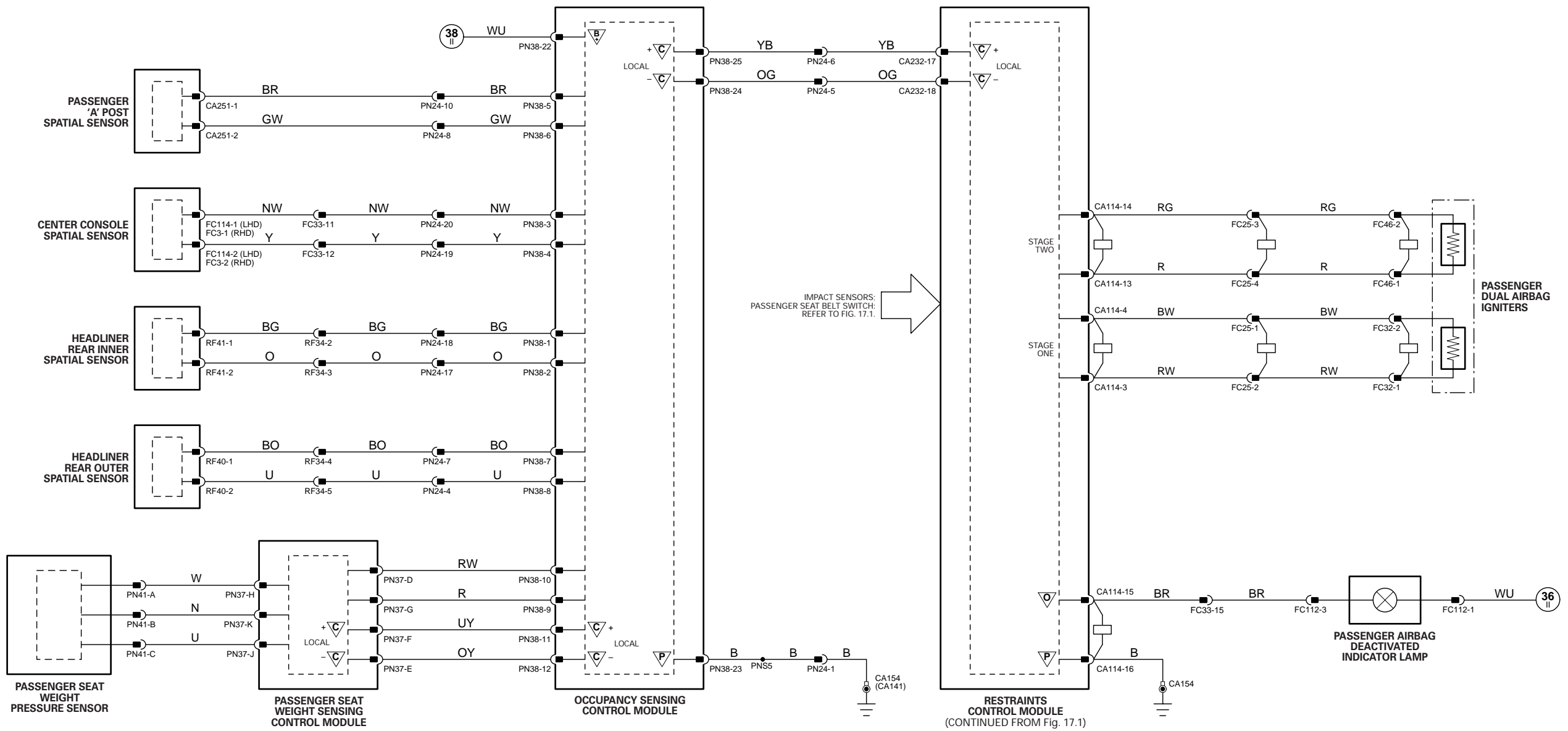

NOTE: RCM power supply shown on Fig. 17.1.

CONTROL MODULE PIN-OUT INFORMATION

Parking Aid Control Module

Pin	Description and Characteristic
B+	CA112-1 IGNITION SWITCHED POWER SUPPLY: B+
PG	CA112-3 POWER GROUND: GROUND
D	CA112-5 SERIAL DATA LINK
I	CA112-8 TRAILER CONNECTED STATUS: GROUND = TRAILER CONNECTED
I	CA112-9 REVERSE LAMPS STATUS: B+ = REVERSE LAMPS ON
D	CA112-10 LH CENTER SENSOR SIGNAL DATA
D	CA112-11 LH SENSOR SIGNAL DATA
O	CA112-14 PARKING AID SOUNDER +
O	CA112-15 SENSOR POWER SUPPLY: B+
O	CA112-16 SENSOR GROUND: GROUND
O	CA112-17 PARKING AID SOUNDER -
D	CA112-23 RH CENTER SENSOR SIGNAL DATA
D	CA112-24 RH SENSOR SIGNAL DATA

Fig. 18.1

COMPONENTS

Component	Connector(s)	Connector Description	Location
LH CENTER SENSOR	BR3	3-WAY / BLACK	REAR BUMPER, LH, CENTER
LH SENSOR	BR2	3-WAY / BLACK	REAR BUMPER, LH
PARKING AID CONTROL MODULE	CA112	26-WAY / BLACK	LUGGAGE COMPARTMENT, LH REAR
PARKING AID SOUNDER	CA32	2-WAY / BLACK	PARCEL SHELF
RH CENTER SENSOR	BR4	3-WAY / BLACK	REAR BUMPER, RH CENTER
RH SENSOR	BR5	3-WAY / BLACK	REAR BUMPER, RH

HARNES IN-LINE CONNECTORS

Connector	Connector Description / Location	Location
BR1	10-WAY / GREY / CABIN HARNESS TO REAR BUMPER HARNESS	BEHIND REAR BUMPER, RH SIDE
CA4A/B	10-WAY / GREY / CABIN HARNESS BRIDGE	LUGGAGE COMPARTMENT, LH REAR

GROUNDS

Ground	Location
CA158	LUGGAGE COMPARTMENT, LH SIDE REAR CORNER

FOR CONTROL MODULE PIN-OUT INFORMATION, UNFOLD PAGE TO LEFT.

The following abbreviations are used to represent values for Control Module Pin-Out data

I	Input	PG	Power Ground	C	CAN Network	D	Serial and Encoded Data
O	Output	SS	Sensor / Signal Supply V	S	SCP Network	V	Voltage (DC)
B+	Battery Voltage	SG	Sensor / Signal Ground	D2	D2B Network	PWM	Pulse Width Modulated

CAUTION: The information on this data page is furnished to aid the user in understanding circuit operation. THIS INFORMATION SHOULD BE USED FOR REFERENCE ONLY.

NOTE: The values listed are approximately those that can be expected at the control module connector pins with all circuit connections made and all components connected and fitted.

Refer to the front of this book for detailed information and illustrations regarding the location and identification of harnesses, relays, fuses, grounds, control modules and control module pins.

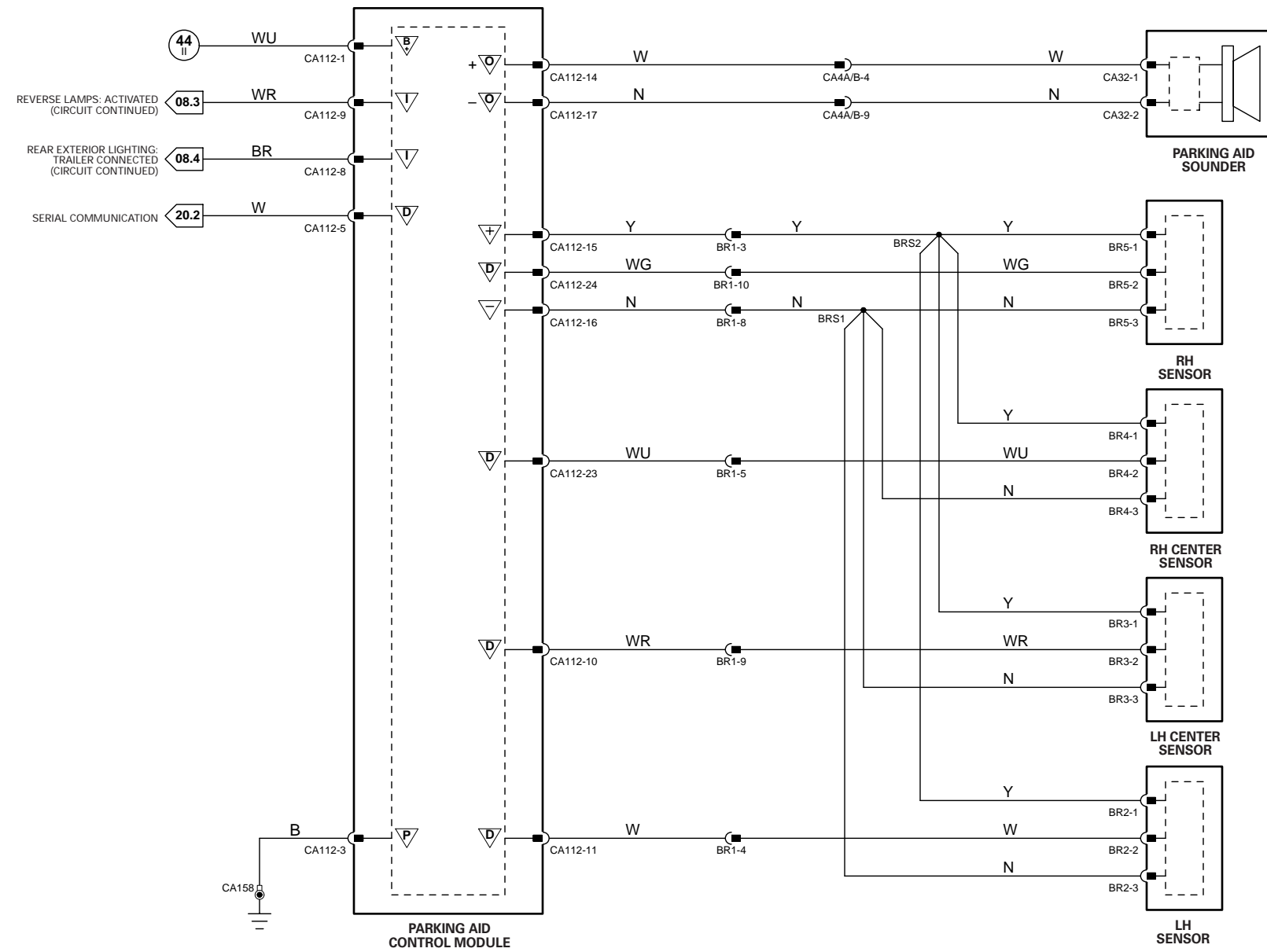

CONTROL MODULE PIN-OUT INFORMATION

General Electronic Control Module

Pin	Description and Characteristic
S FH59-1	SCP -
B+ FH59-6	BATTERY POWER SUPPLY (LOGIC): B+
S FH59-7	SCP +
O FH59-8	HORN RELAY ACTIVATE: TO ACTIVATE, GECM SWITCHES CIRCUIT TO GROUND
B+ FH60-1	SWITCHED SYSTEM POWER SUPPLY: B+
PG FH60-11	POWER GROUND: GROUND

Instrument Cluster

Pin	Description and Characteristic
SG FC14-14	SIGNAL GROUND: GROUND
I FC14-21	HORN SWITCH SIGNAL: ACTIVATE = MOMENTARY GROUND
B+ FC15-3	BATTERY POWER SUPPLY (LOGIC): B+
S FC15-10	SCP -
S FC15-20	SCP +

NOTE: Refer to the Appendix at the rear of this book for Network Messages.

Fig. 19.1

COMPONENTS

Component	Connector(s)	Connector Description	Location
ACCESSORY CONNECTOR	CA13	3-WAY / BLACK	ADJACENT TO REAR ELECTRONIC CONTROL MODULE
ACCESSORY RELAY	—	—	REAR POWER DISTRIBUTION FUSE BOX – R10
CIGAR LIGHTER / POWER POINT RELAY	—	—	PRIMARY JUNCTION FUSE BOX – R1
CIGAR LIGHTER	CA109	3-WAY / BLACK	CENTER CONSOLE
ELECTRONIC ROAD PRICING MODULE	SL5	NOT AVAILABLE	INSTRUMENT PANEL
FRONT POWER DISTRIBUTION FUSE BOX	—	—	ENGINE COMPARTMENT, RH SIDE
GENERAL ELECTRONIC CONTROL MODULE	FH9	22-WAY / BLACK	LH 'A' POST
	CA24	26-WAY / NATURAL	
	CA31	20-WAY / BLACK	
	FH59	12-WAY / BLACK	
	FH60	17-WAY / BLACK	
HORN RELAY	—	—	FRONT POWER DISTRIBUTION FUSE BOX – R12
HORNS	FH29	2-WAY / BLACK	FORWARD OF RADIATOR
INSTRUMENT CLUSTER	FC14	22-WAY / GREY	INSTRUMENT PANEL
	FC15	20-WAY / BLACK	
	FC63	22-WAY / BLACK	
POWER POINT	CA237	3-WAY / BROWN	ADJACENT TO CIGAR LIGHTER
PRIMARY JUNCTION FUSE BOX	CA2	26-WAY / BLACK	RH 'A' POST
	CA56	8-WAY / BLACK	
	FC37	26-WAY / BLACK	
	FH7	6-WAY / BLACK	
	FH53	10-WAY / BLACK	
REAR POWER DISTRIBUTION FUSE BOX	—	—	LUGGAGE COMPARTMENT
ROOF CONSOLE	CA250	22-WAY / BLACK	ROOF HEADLINER
STEERING WHEEL HORN SWITCH	SO2	6-WAY / BLACK	STEERING WHEEL
SUN SHADE MOTOR	CA254	4-WAY / BLACK	LH 'D' POST, ADJACENT TO SEAT BELT RETRACTOR

HARNESS IN-LINE CONNECTORS

Connector	Connector Description / Location	Location
FC10	14-WAY / GREEN / FASCIA HARNESS TO FRONT HARNESS	BEHIND INSTRUMENT PANEL, RH SIDE
FC117	10-WAY / BLACK / STEERING WHEEL CASSETTE	STEERING COLUMN
PI41	42-WAY / BLACK / ENGINE HARNESS TO VEHICLE HARNESSES	ENGINE COMPARTMENT, BULKHEAD, PASSENGER SIDE
SL3	10-WAY / GREY / FASCIA HARNESS TO SOLAR SENSOR LINK	BEHIND INSTRUMENT PANEL, RH SIDE

GROUNDS

Ground	Location
CA50	RH LOWER 'A' POST, BELOW PRIMARY JUNCTION FUSE BOX
CA141	UNDER LH FRONT SEAT
CA156	LUGGAGE COMPARTMENT, RH SIDE
CA157	LUGGAGE COMPARTMENT, LH SIDE AFT OF WHEEL ARCH
FC38	UNDER CENTER OF INSTRUMENT PANEL, ON TRANSMISSION TUNNEL
FH42	ENGINE COMPARTMENT, BEHIND RH HEADLAMP
FH77	LH LOWER 'A' POST, ADJACENT TO THE GENERAL ELECTRONIC CONTROL MODULE (FORWARD OF CA30)

FOR CONTROL MODULE PIN-OUT INFORMATION, UNFOLD PAGE TO LEFT.

The following abbreviations are used to represent values for Control Module Pin-Out data

I	Input	PG	Power Ground	C	CAN Network	D	Serial and Encoded Data
O	Output	SS	Sensor / Signal Supply V	S	SCP Network	V	Voltage (DC)
B+	Battery Voltage	SG	Sensor / Signal Ground	D2	D2B Network	PWM	Pulse Width Modulated

CAUTION: The information on this data page is furnished to aid the user in understanding circuit operation. THIS INFORMATION SHOULD BE USED FOR REFERENCE ONLY.

NOTE: The values listed are approximately those that can be expected at the control module connector pins with all circuit connections made and all components connected and fitted.

Refer to the front of this book for detailed information and illustrations regarding the location and identification of harnesses, relays, fuses, grounds, control modules and control module pins.

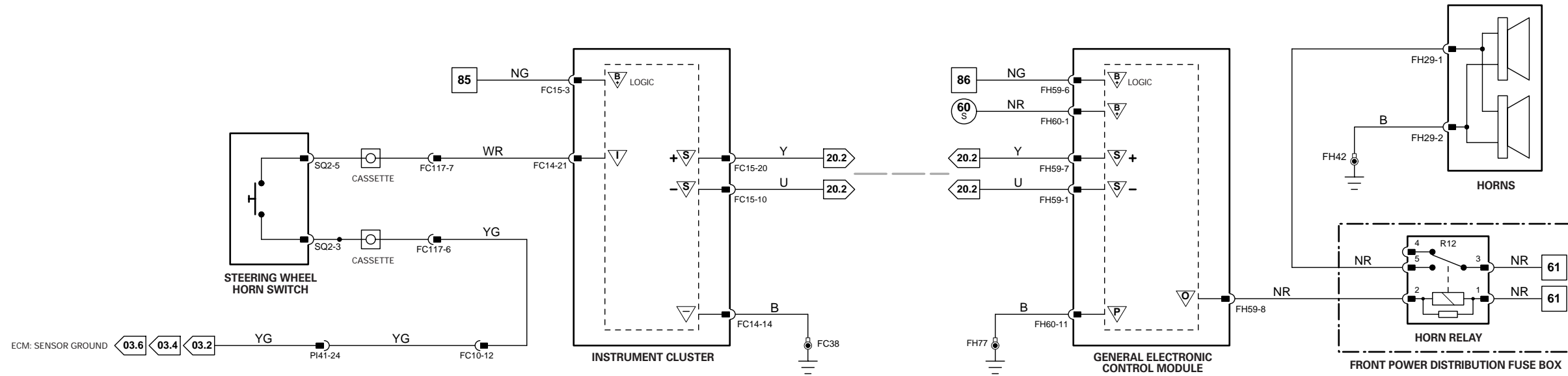

HORNS

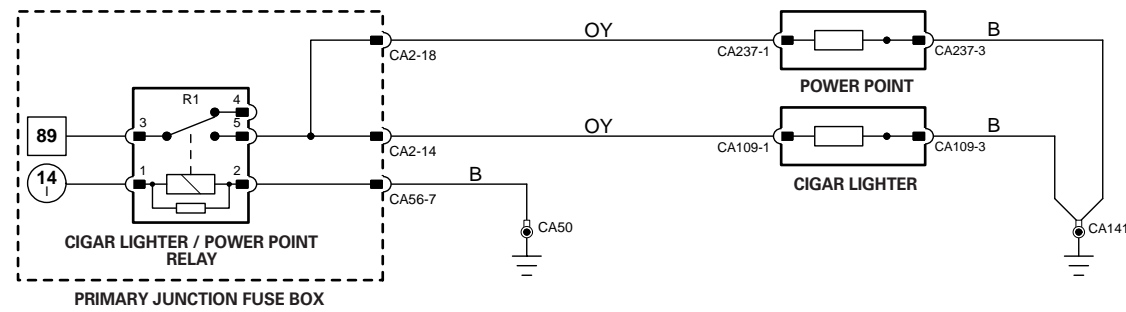

CIGAR LIGHTER; POWER POINT

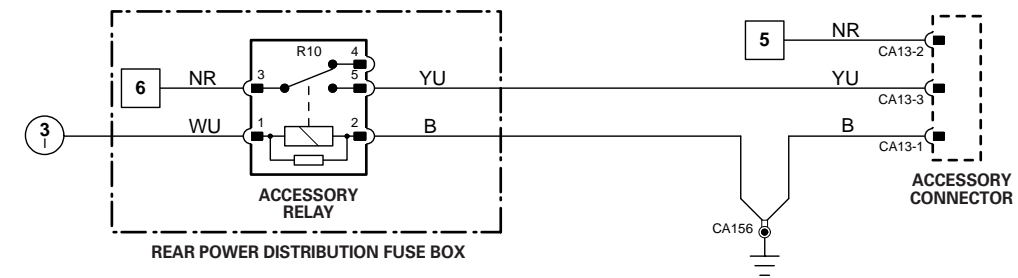

ACCESSORY CONNECTOR

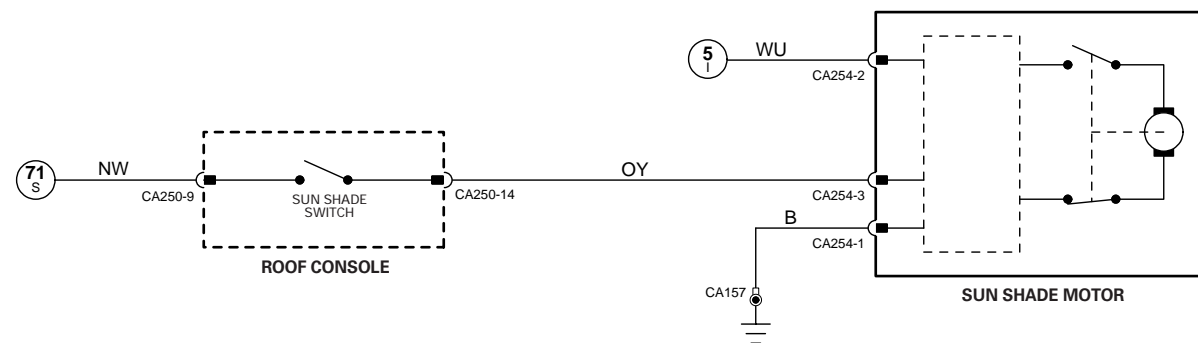

SUN SHADE

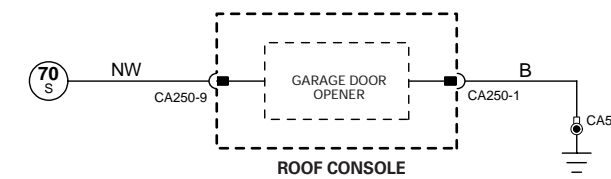

GARAGE DOOR OPENER

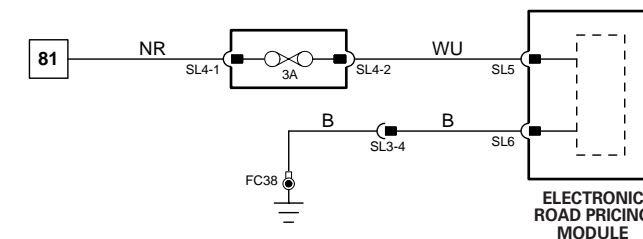

ELECTRONIC ROAD PRICING

Fig. 20.1**COMPONENTS**

Component	Connector(s)	Connector Description	Location
ADAPTIVE SPEED CONTROL CONTROL MODULE	FH107	12-WAY BLACK	BELOW LH FRONT BUMPER
AIR CONDITIONING CONTROL MODULE - PANEL	FC27 FC28	26-WAY / GREY 22-WAY / GREY	CENTER CONSOLE
AIR CONDITIONING CONTROL MODULE - REMOTE	FC40 FC41	26-WAY / GREY 22-WAY / GREY	BEHIND INSTRUMENT PANEL, RH SIDE (LHD), LH SIDE (RHD)
DATA LINK CONNECTOR	FC1	DATA LINK CONNECTOR	BELOW INSTRUMENT PANEL, LH SIDE
DYNAMIC STABILITY CONTROL CONTROL MODULE	FH103	47-WAY / BLACK	ENGINE COMPARTMENT, RH FRONT
ENGINE CONTROL MODULE	PI1	134-WAY / BLACK	FRONT BULKHEAD, PASSENGER SIDE
HEADLAMP LEVELING CONTROL MODULE	FH12	26-WAY / BLACK	RH 'A' POST, ABOVE PRIMARY JUNCTION FUSE BOX
INSTRUMENT CLUSTER	FC14 FC15 FC63	22-WAY / GREY 20-WAY / BLACK 22-WAY / BLACK	INSTRUMENT PANEL
J GATE MODULE	CA245	16-WAY / BLACK	J GATE ASSEMBLY
TRANSMISSION CONTROL MODULE	GB2	16-WAY / BLACK	TRANSMISSION CONTROL VALVE ASSEMBLY

HARNESS IN-LINE CONNECTORS

Connector	Connector Description / Location	Location
FC39	10-WAY / GREY / CABIN HARNESS TO FASCIA HARNESS	BEHIND INSTRUMENT PANEL, RH SIDE
FH1	20-WAY / BLACK / CABIN HARNESS TO FRONT HARNESS	RH 'A' POST, LOWER
GB1	16-WAY / GREY / ENGINE HARNESS TO TRANSMISSION HARNESS	ADJACENT TO TRANSMISSION BELL HOUSING
PI41	42-WAY / BLACK / ENGINE HARNESS TO VEHICLE HARNESSES	ENGINE COMPARTMENT, BULKHEAD, PASSENGER SIDE

GROUNDS

Ground	Location
FC38	UNDER CENTER OF INSTRUMENT PANEL, ON TRANSMISSION TUNNEL

NOTE: Refer to the Appendix at the rear of this book for Network Messages.

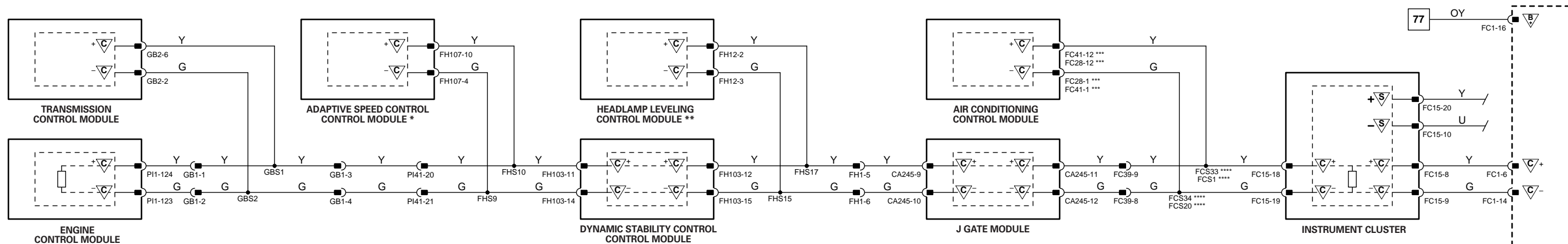

AUTOMATIC TRANSMISSION VEHICLES

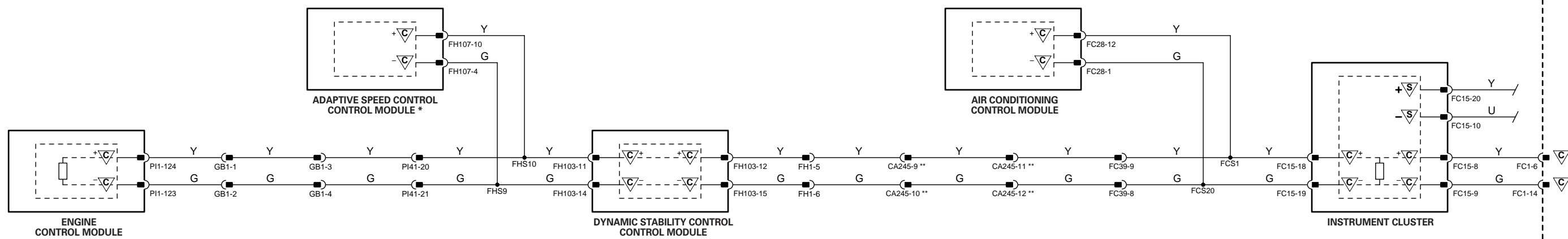

MANUAL TRANSMISSION VEHICLES

NOTES:

- * Adaptive Speed Control Control Module and circuit – adaptive speed control vehicles only.
- ** Headlamp Leveling Control Module – HID vehicles only.
- *** FC41 – remote A/CCM with navigation; FC28 – A/CCM with panel controls.
- **** FCS33 and FCS34 – A/CCM with panel controls; FCS1 and FCS20 – remote A/CCM with navigation.

NOTES:

- * Adaptive Speed Control Control Module and circuit – adaptive speed control vehicles only.
- ** CA245 and circuit – fitted to certain vehicles only.

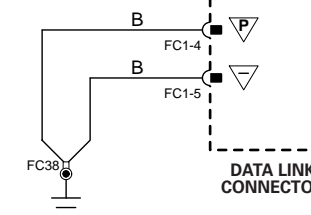

Fig. 20.2

COMPONENTS

Component	Connector(s)	Connector Description	Location
ADAPTIVE DAMPING CONTROL MODULE	CA11 CA12	16-WAY / BLUE 16-WAY / GREY	LUGGAGE COMPARTMENT, REAR
AUDIO UNIT	FC94 FC96 FC108	20-WAY / BLACK ANTENNA CONNECTOR FIBER OPTIC CONNECTOR	CENTER CONSOLE
DATA LINK CONNECTOR	FC1	DATA LINK CONNECTOR	BELOW INSTRUMENT PANEL, LH SIDE
DRIVER DOOR CONTROL MODULE	CA85 DD4 DT2	12-WAY / BLACK 26-WAY / NATURAL 20-WAY / BLACK	DRIVER DOOR
DRIVER SEAT CONTROL MODULE	DM33 DM34 DM35 DM36 DM37 DM38	26-WAY / BLACK 22-WAY / BLACK 6-WAY / BLACK 4-WAY / BLACK 4-WAY / BLACK 6-WAY / BLACK	UNDER DRIVER SEAT
PARKING BRAKE CONTROL MODULE	CA241 CA242	4-WAY / BLACK 12-WAY / BLACK	LUGGAGE COMPARTMENT, RH REAR
ENGINE CONTROL MODULE	PH1	134-WAY / BLACK	FRONT BULKHEAD, PASSENGER SIDE
GENERAL ELECTRONIC CONTROL MODULE	FH9 CA24 CA31 FH59 FH60	22-WAY / BLACK 26-WAY / NATURAL 20-WAY / BLACK 12-WAY / BLACK 17-WAY / BLACK	LH 'A' POST
HEADLAMP LEVELING CONTROL MODULE	FH12	26-WAY / BLACK	RH 'A' POST, ABOVE PRIMARY JUNCTION FUSE BOX
INSTRUMENT CLUSTER	FC14 FC15 FC63	22-WAY / GREY 20-WAY / BLACK 22-WAY / BLACK	INSTRUMENT PANEL
NAVIGATION CONTROL MODULE	CA176 CA257 CA258 CA259 RA5	2-WAY / GREY 26-WAY / NATURAL 20-WAY / BLACK 12-WAY / BLACK FIBER OPTIC CONNECTOR	LUGGAGE COMPARTMENT, LH REAR
PARKING AID CONTROL MODULE	CA112	26-WAY / BLACK	LUGGAGE COMPARTMENT, LH REAR
REAR ELECTRONIC CONTROL MODULE	CA63 CA100 CA101 CA102 CA103	17-WAY / BLACK 12-WAY / BLACK 20-WAY / BLACK 22-WAY / BLACK 26-WAY / NATURAL	LUGGAGE COMPARTMENT, RH REAR
RESTRAINTS CONTROL MODULE	CA114 CA232	24-WAY / BLACK 40-WAY / BLACK	TRANSMISSION TUNNEL, UNDER CENTER CONSOLE
ROOF CONSOLE	CA250	22-WAY / BLACK	ROOF HEADLINER
STEERING COLUMN LOCK CONTROL MODULE	FC59	4-WAY / BLACK	ADJACENT TO STEERING COLUMN LOCK

HARNESS IN-LINE CONNECTORS

Connector	Connector Description / Location	Location
DM23	20-WAY / BLACK / CABIN HARNESS TO DRIVER SEAT HARNESS	UNDER DRIVER SEAT
FC17	16-WAY / BLUE / CABIN HARNESS TO FASCIA HARNESS	BEHIND INSTRUMENT PANEL, PASSENGER SIDE
FC33	16-WAY / GREEN / CABIN HARNESS TO FASCIA HARNESS	BEHIND INSTRUMENT PANEL, RH SIDE
FH6	16-WAY GREEN / CABIN HARNESS TO FRONT HARNESS	LH 'A' POST, ADJACENT TO GECM
PI41	42-WAY / BLACK / ENGINE HARNESS TO VEHICLE HARNESSES	ENGINE COMPARTMENT, BULKHEAD, PASSENGER SIDE

GROUNDS

Ground	Location
FC38	UNDER CENTER OF INSTRUMENT PANEL, ON TRANSMISSION TUNNEL

NOTE: Refer to the Appendix at the rear of this book for Network Messages.

Refer to the front of this book for detailed information and illustrations regarding the location and identification of harnesses, relays, fuses, grounds, control modules and control module pins.

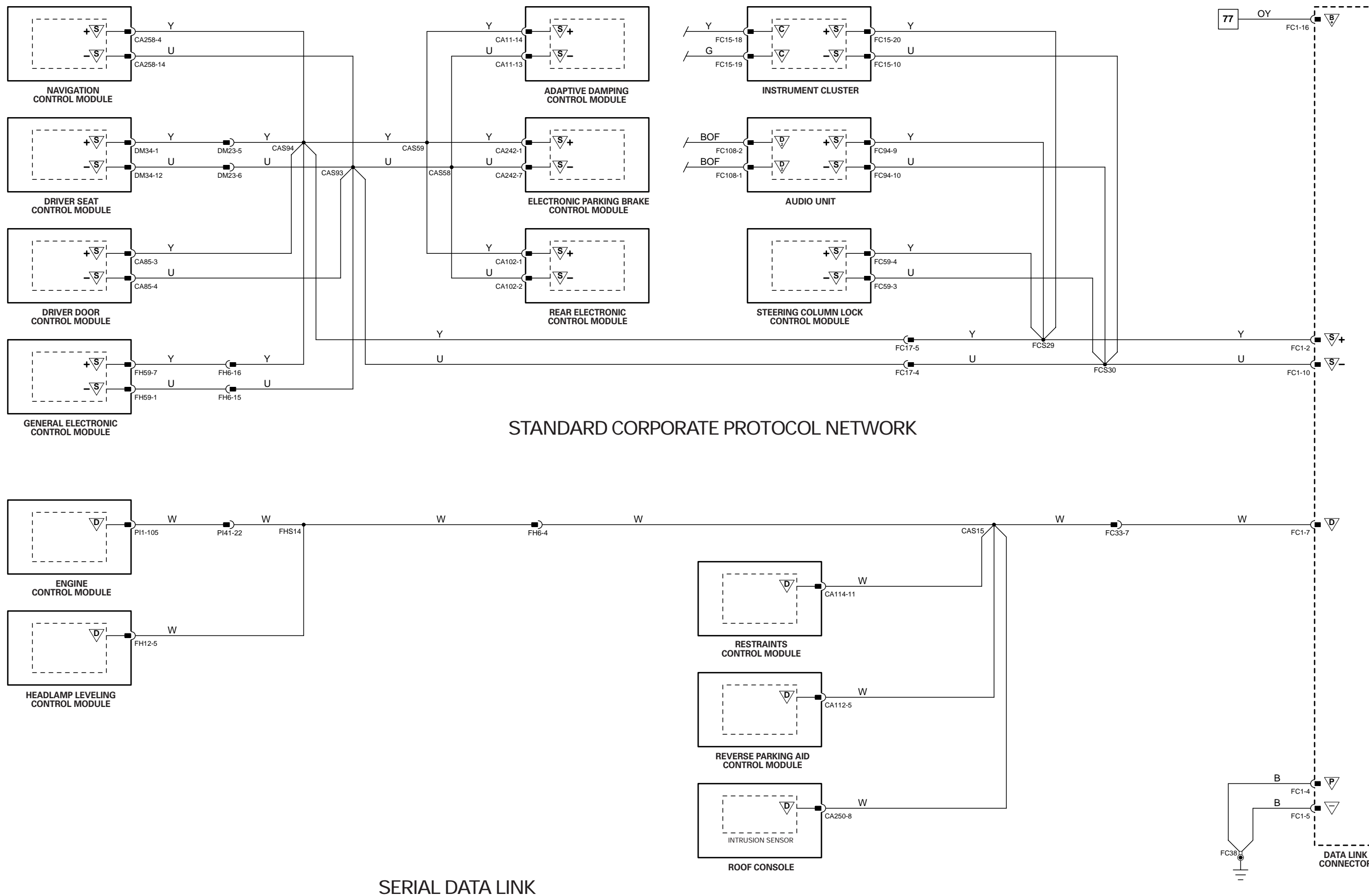

STANDARD CORPORATE PROTOCOL NETWORK

SERIAL DATA LINK

1 → 3 Fig. 01.1	4 → 76 Fig. 01.2	77 → 92 Fig. 01.3	1 → 14 Fig. 01.4	15 → 45 Fig. 01.5	46 → 80 Fig. 01.6	81 → 118 Fig. 01.7	Input	Battery Voltage	Sensor/Signal Supply V	CAN	D2B Network
							Output	Power Ground	Sensor/Signal Ground	SCP	Serial and Encoded Data

VARIANT: All Vehicles
 VIN RANGE: All
 DATE OF ISSUE: June 2002

Fig. 20.3**COMPONENTS**

Component	Connector(s)	Connector Description	Location
AUDIO UNIT	FC94 FC96 FC108	20-WAY / BLACK ANTENNA CONNECTOR FIBER OPTIC CONNECTOR	CENTER CONSOLE
CD AUTOCHANGER	CA267 RA2	3-WAY / BLACK FIBER OPTIC CONNECTOR	LUGGAGE COMPARTMENT, LH REAR
CELLULAR PHONE CONTROL MODULE	CA209 CA210 CA211 CA261 RA3	2-WAY / BLACK 2-WAY / BLACK 2-WAY / BLACK 32-WAY / BLACK FIBER OPTIC CONNECTOR	LUGGAGE COMPARTMENT, LH REAR
NAVIGATION CONTROL MODULE	CA176 CA257 CA258 CA259 RA5	2-WAY / GREY 26-WAY / NATURAL 20-WAY / BLACK 12-WAY / BLACK FIBER OPTIC CONNECTOR	LUGGAGE COMPARTMENT, LH REAR
POWER AMPLIFIER	CA263 CA264 RA6	POWER AMPLIFIER CONNECTOR POWER AMPLIFIER CONNECTOR FIBER OPTIC CONNECTOR	LUGGAGE COMPARTMENT, LH REAR
VOICE ACTIVATION CONTROL MODULE	CA300 RA4	22-WAY / GREY FIBER OPTIC CONNECTOR	LUGGAGE COMPARTMENT, LH REAR

HARNESS IN-LINE CONNECTORS

Connector	Connector Description / Location	Location
FC107	2-WAY / BLACK / FIBER OPTIC IN-LINE CONNECTOR	UNDER CENTER CONSOLE
FC23	10-WAY / GREY / CABIN HARNESS TO FASCIA HARNESS	BEHIND INSTRUMENT PANEL, LH SIDE
RA1	2-WAY / FIBER OPTIC / FIBER OPTIC IN-LINE CONNECTOR	LUGGAGE COMPARTMENT, LH SIDE

Refer to the front of this book for detailed information and illustrations regarding the location and identification of harnesses, relays, fuses, grounds, control modules and control module pins.

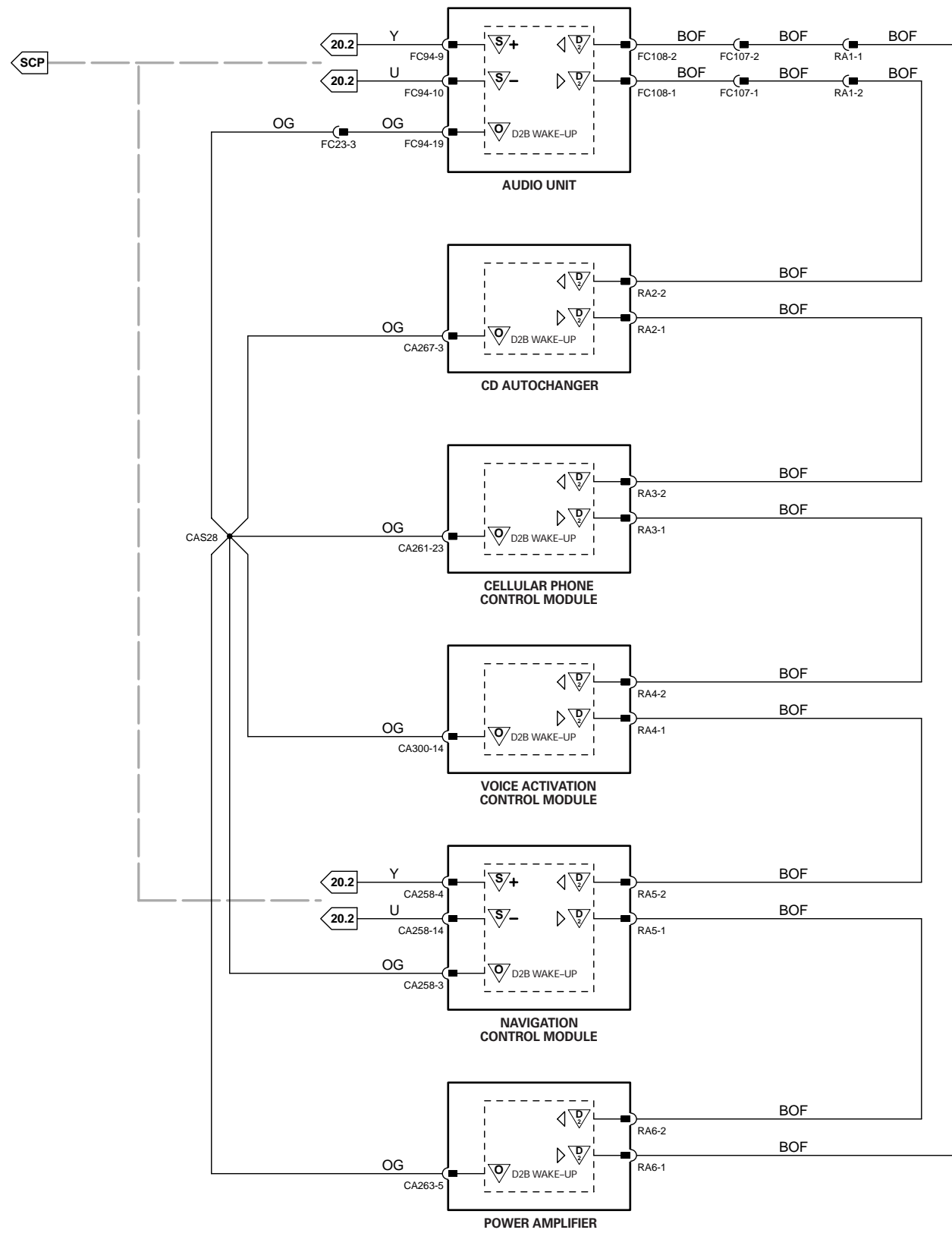

D2B NETWORK WAKE-UP; 6-MODULE NETWORK

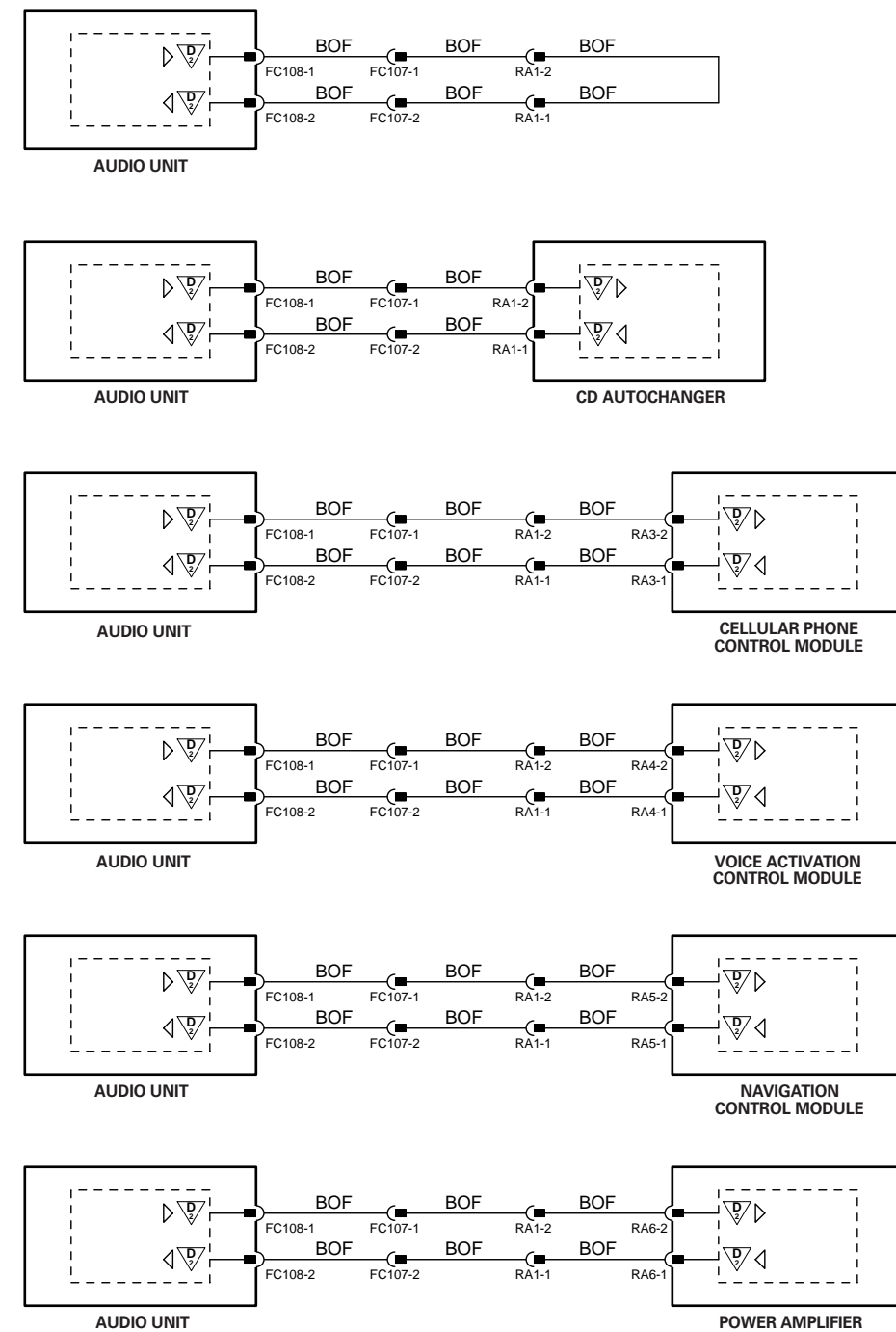

2-MODULE NETWORKS

NOTES:

Figures 20.3, 20.4 and 20.5 show all possible combinations of D2B networks.

D2B network diagnostics via SCP – Refer to Fig. 20.2.

Fig. 20.4**COMPONENTS**

Component	Connector(s)	Connector Description	Location
AUDIO UNIT	FC94 FC96 FC108	20-WAY / BLACK ANTENNA CONNECTOR FIBER OPTIC CONNECTOR	CENTER CONSOLE
CD AUTOCHANGER	CA267 RA2	3-WAY / BLACK FIBER OPTIC CONNECTOR	LUGGAGE COMPARTMENT, LH REAR
CELLULAR PHONE CONTROL MODULE	CA209 CA210 CA211 CA261 RA3	2-WAY / BLACK 2-WAY / BLACK 2-WAY / BLACK 32-WAY / BLACK FIBER OPTIC CONNECTOR	LUGGAGE COMPARTMENT, LH REAR
NAVIGATION CONTROL MODULE	CA176 CA257 CA258 CA259 RA5	2-WAY / GREY 26-WAY / NATURAL 20-WAY / BLACK 12-WAY / BLACK FIBER OPTIC CONNECTOR	LUGGAGE COMPARTMENT, LH REAR
POWER AMPLIFIER	CA263 CA264 RA6	POWER AMPLIFIER CONNECTOR POWER AMPLIFIER CONNECTOR FIBER OPTIC CONNECTOR	LUGGAGE COMPARTMENT, LH REAR
VOICE ACTIVATION CONTROL MODULE	CA300 RA4	22-WAY / GREY FIBER OPTIC CONNECTOR	LUGGAGE COMPARTMENT, LH REAR

HARNESS IN-LINE CONNECTORS

Connector	Connector Description / Location	Location
FC107	2-WAY / BLACK / FIBER OPTIC IN-LINE CONNECTOR	UNDER CENTER CONSOLE
FC23	10-WAY / GREY / CABIN HARNESS TO FASCIA HARNESS	BEHIND INSTRUMENT PANEL, LH SIDE
RA1	2-WAY / FIBER OPTIC / FIBER OPTIC IN-LINE CONNECTOR	LUGGAGE COMPARTMENT, LH SIDE

Refer to the front of this book for detailed information and illustrations regarding the location and identification of harnesses, relays, fuses, grounds, control modules and control module pins.

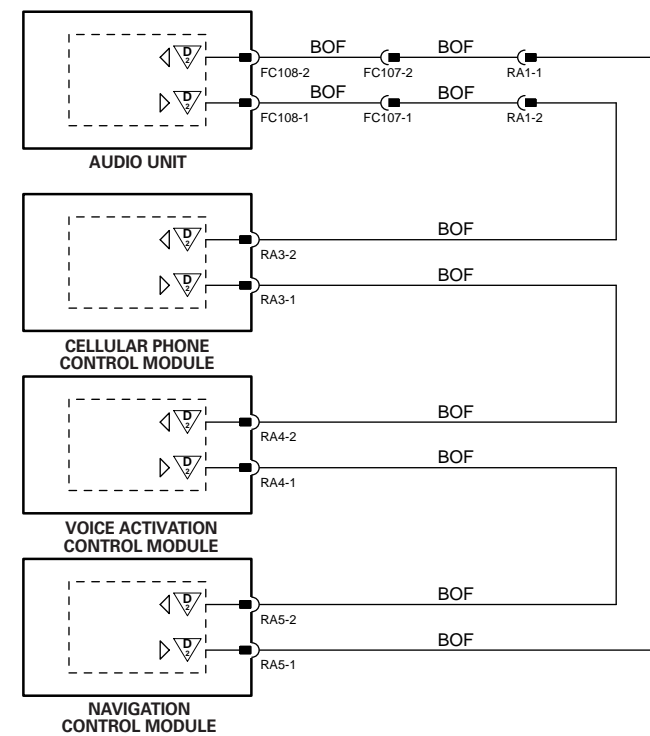
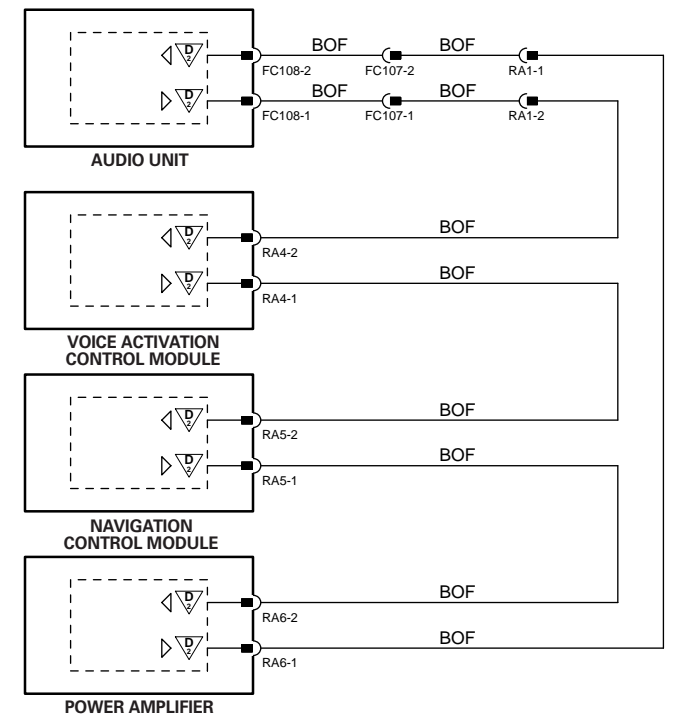
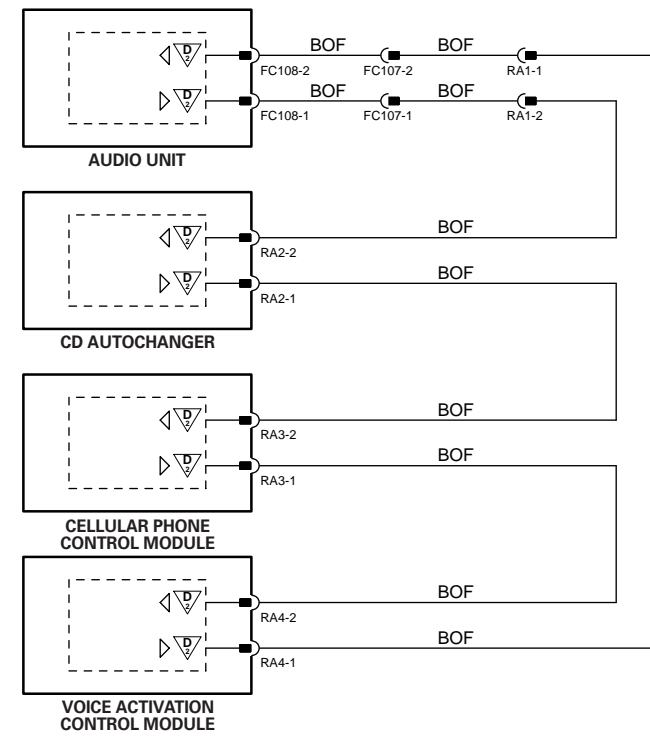
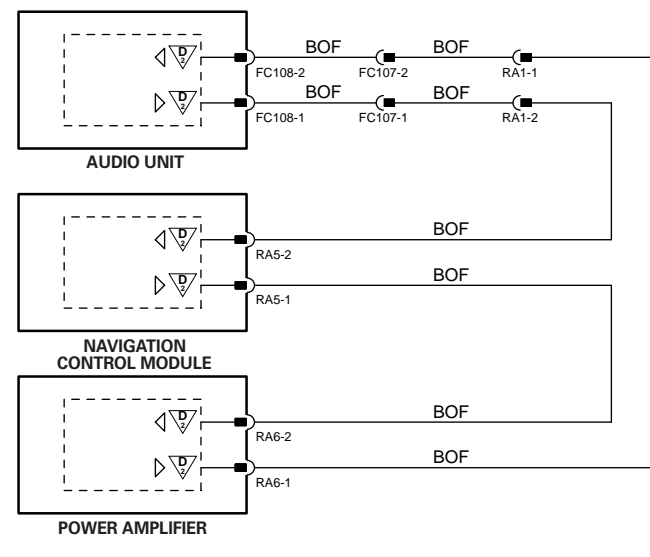
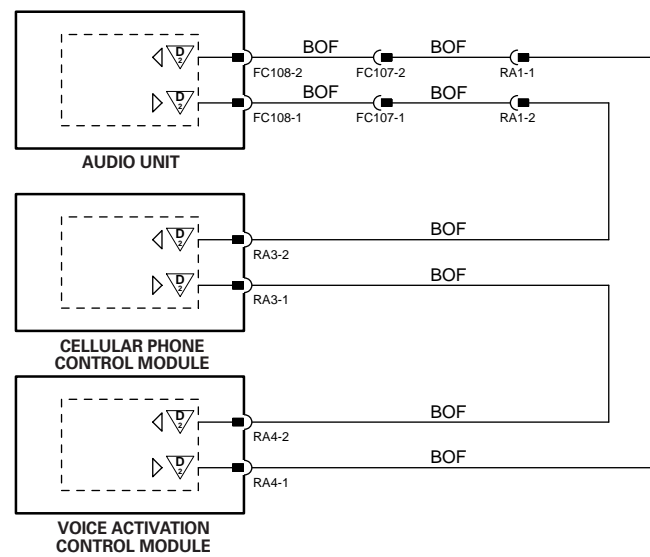
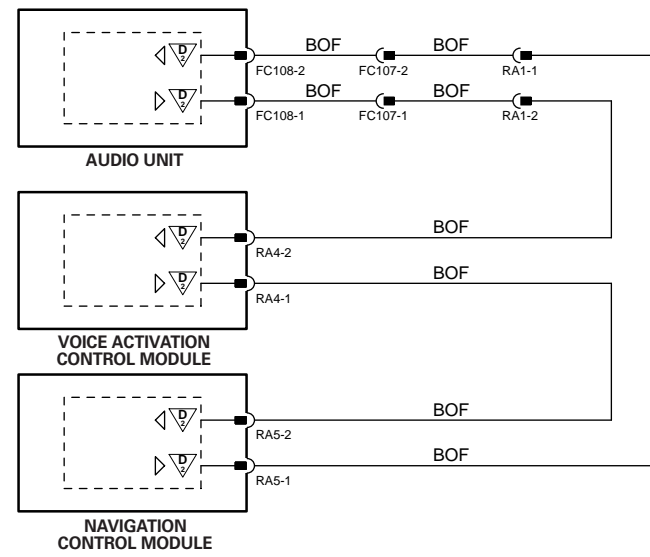
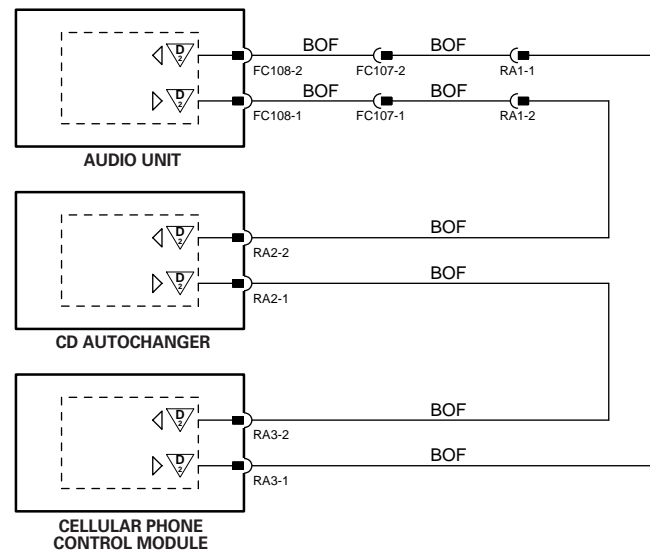

3-MODULE NETWORKS

4-MODULE NETWORKS

NOTES:

Figures 20.3, 20.4 and 20.5 show all possible combinations of D2B networks.

D2B network diagnostics via SCP – Refer to Fig. 20.2.

Fig. 01.1	Fig. 01.2	Fig. 01.3	Fig. 01.4	Fig. 01.5	Fig. 01.6	Fig. 01.7	Input	Battery Voltage	Sensor/Signal Supply V	CAN	D2B Network
Output	Power Ground	Sensor/Signal Ground	SCP	Serial and Encoded Data							

VARIANT: All Vehicles
 VIN RANGE: All
 DATE OF ISSUE: June 2002

Fig. 20.5**COMPONENTS**

Component	Connector(s)	Connector Description	Location
AUDIO UNIT	FC94 FC96 FC108	20-WAY / BLACK ANTENNA CONNECTOR FIBER OPTIC CONNECTOR	CENTER CONSOLE
CD AUTOCHANGER	CA267 RA2	3-WAY / BLACK FIBER OPTIC CONNECTOR	LUGGAGE COMPARTMENT, LH REAR
CELLULAR PHONE CONTROL MODULE	CA209 CA210 CA211 CA261 RA3	2-WAY / BLACK 2-WAY / BLACK 2-WAY / BLACK 32-WAY / BLACK FIBER OPTIC CONNECTOR	LUGGAGE COMPARTMENT, LH REAR
NAVIGATION CONTROL MODULE	CA176 CA257 CA258 CA259 RA5	2-WAY / GREY 26-WAY / NATURAL 20-WAY / BLACK 12-WAY / BLACK FIBER OPTIC CONNECTOR	LUGGAGE COMPARTMENT, LH REAR
POWER AMPLIFIER	CA263 CA264 RA6	POWER AMPLIFIER CONNECTOR POWER AMPLIFIER CONNECTOR FIBER OPTIC CONNECTOR	LUGGAGE COMPARTMENT, LH REAR
VOICE ACTIVATION CONTROL MODULE	CA300 RA4	22-WAY / GREY FIBER OPTIC CONNECTOR	LUGGAGE COMPARTMENT, LH REAR

HARNESS IN-LINE CONNECTORS

Connector	Connector Description / Location	Location
FC107	2-WAY / BLACK / FIBER OPTIC IN-LINE CONNECTOR	UNDER CENTER CONSOLE
FC23	10-WAY / GREY / CABIN HARNESS TO FASCIA HARNESS	BEHIND INSTRUMENT PANEL, LH SIDE
RA1	2-WAY / FIBER OPTIC / FIBER OPTIC IN-LINE CONNECTOR	LUGGAGE COMPARTMENT, LH SIDE

Refer to the front of this book for detailed information and illustrations regarding the location and identification of harnesses, relays, fuses, grounds, control modules and control module pins.

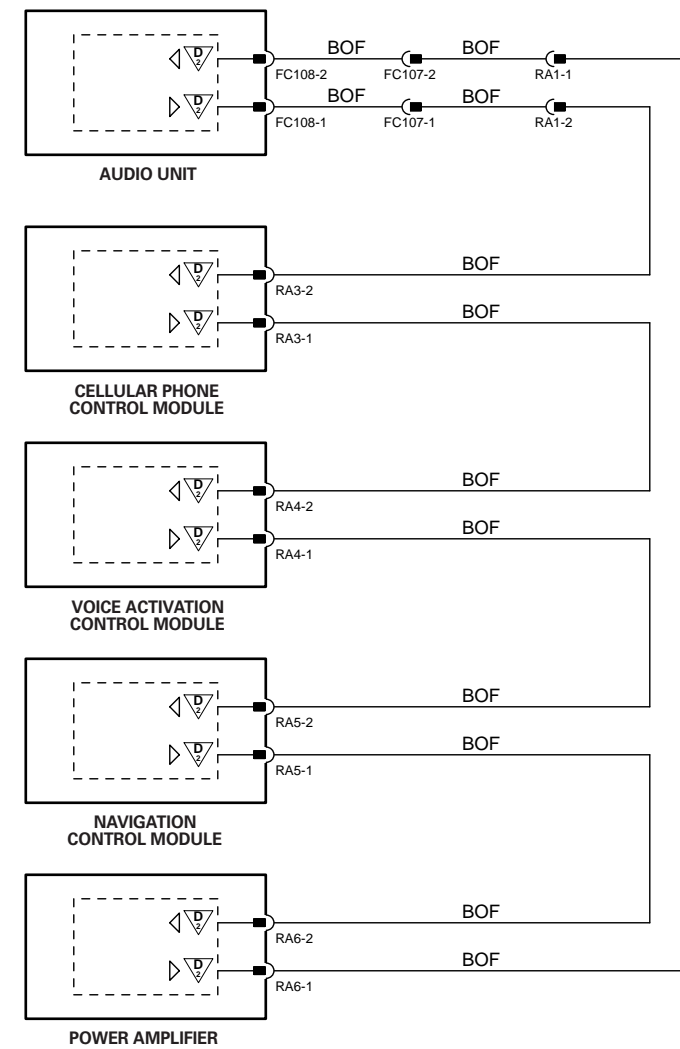
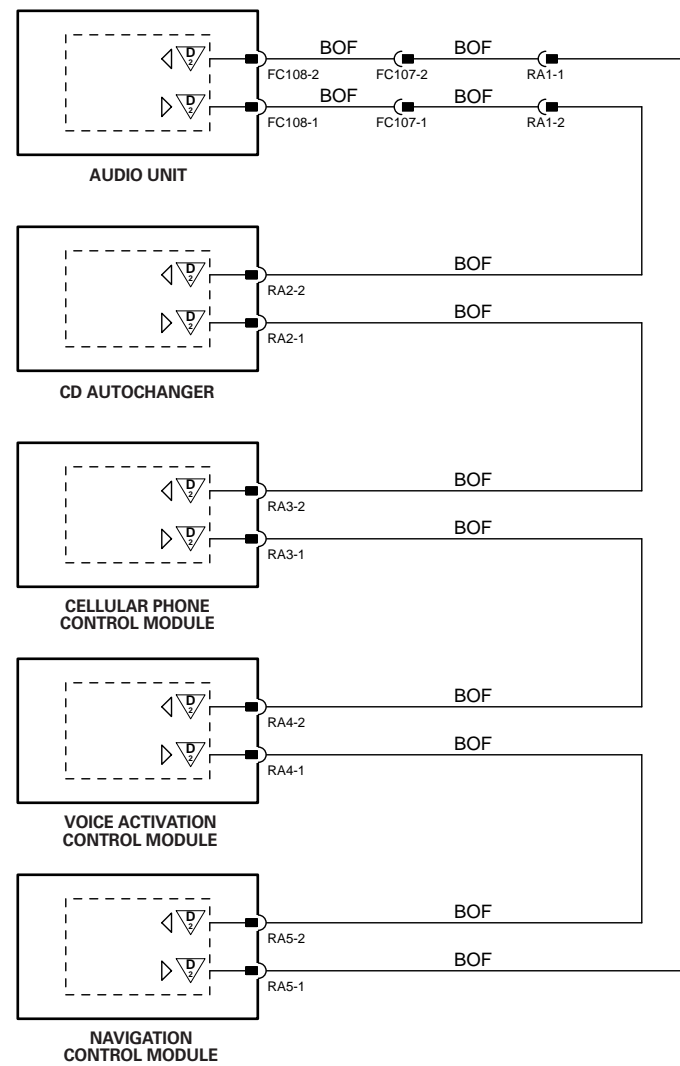

5-MODULE NETWORKS

NOTES:

Figures 20.3, 20.4 and 20.5 show all possible combinations of D2B networks.
D2B network diagnostics via SCP – Refer to Fig. 20.2.



This Appendix contains a listing of SCP and CAN Network messages.

NOTE: Passive Anti-Theft System and Security System messages are not included in this appendix.

The following acronyms and abbreviations are used throughout this section:

A/C	Air Conditioning
A/CCM	Air Conditioning Control Module
ADCM	Adaptive Damping Control Module
AIRCON	Climate Control
ASC	Adaptive Speed Control
ASCCM	Adaptive Speed Control Control Module
AT CMD	Commands for configuring and controlling telecommunication devices
AUDIO	Audio Unit
CAL	Calibrate
CAN	Controller Area Network
CID	CAN Identifier
CM	Control Module
CONFIG	Configure
CPCM	Cellular Phone Control Module
D2B OPC	Instructions for translating and routing data for D2B use
D2B	Fiber Optic Network
DDCM	Driver Door Control module
DIAG	Diagnostics (WDS)
DSC	Dynamic Stability Control
DSCCM	Dynamic Stability Control Control Module
DTC	Diagnostic Trouble Code
ECM	Engine Control Module
FL	Front Left
FR	Front Right
Gateway	Device that converts messages between different types of networks
GECM	General Electronic Control Module
HLCM	Headlight Leveling Control Module
IC	Instrument Cluster
ID	Identification
JGM	J Gate Module
LED	Light Emitting Diode
MIL	Malfunction Indicator Lamp
MSG	Message
NCM	Navigation Control Module
ODO	Odometer
PATS	Passive Anti-Theft System
PBCM	Parking Brake Control Module
PECUS	Programmable Electronic Control Units System
PTT	Push to Talk
RECM	Rear Electronic Control Module
RL	Rear Left
RPM	Revolutions Per Minute
RR	Rear Right
SCLCM	Steering Column Locking Control Module
SCP	Standard Corporate Protocol Network
SMS	Short Message Service for Mobile Communications
STM	Switch to Test Mode
TCM	Transmission Control Module
TCS	Traction Control System
VACM	Voice Activation Control Module
VEMS	JaguarNet
VOICE	Voice Activation Control
WDS	Worldwide Diagnostic System



SCP Message Matrix

No.	Message Name	Source	Receivers												
			ADCM	PBCM	RECM	GECM	IC	NCM	AUDIO	DDCM	DSCM	SCLCM			
1	All Courtesy Lamp Status: OFF	GECM						X							
2	All Courtesy Lamp Status: ON	GECM						X							
3	All Courtesy Lamp Switch Status: Active	IC					X								
4	All Courtesy Lamp Switch Status: Inactive	IC					X								
5	ALL Door Lock Command: Lock(ed)	DDCM			X										
6	ALL Door Lock Command: Lock(ed)	RECM									X				
7	ALL Door Lock Command: Unlock(ed)	DDCM			X										
8	ALL Door Lock Command: Unlock(ed)	RECM										X			
9	ALL Door Lock Motor Enable Command: Disabled(d)	DDCM			X										
10	All Front Fog Lamp Command: OFF	IC					X								
11	All Front Fog Lamp Command: ON	IC					X								
12	All Front Fog Lamp Status: OFF	GECM						X							
13	All Front Fog Lamp Status: ON	GECM						X							
14	ALL Front High Beam Lamp Command: OFF	IC					X								
15	ALL Front High Beam Lamp Command: ON	IC					X								
16	ALL Front High Beam Lamp Status: OFF	GECM						X							
17	ALL Front High Beam Lamp Status: ON	GECM						X							
18	ALL Headlamp Command: OFF	IC					X								
19	ALL Headlamp Command: ON	IC					X								
20	ALL Headlamp Status: OFF	GECM						X							
21	ALL Headlamp Status: ON	GECM						X							
22	ALL Park Lamp Command: OFF	IC			X		X					X			
23	ALL Park Lamp Command: ON	IC			X		X					X			
24	All Rear Brake Lamp Command: OFF	PBCM			X										
25	All Rear Brake Lamp Command: ON	PBCM			X										
26	All Rear Fog Lamp Command: OFF	IC			X										
27	All Rear Fog Lamp Command: ON	IC			X										
28	All Rear Fog Lamp Status: OFF	RECM							X						
29	All Rear Fog Lamp Status: ON	RECM							X						
30	All Rear Park Lamp Command: OFF	GECM			X										
31	All Rear Park Lamp Command: ON	GECM			X										
32	All Rear Window Lockout Switch Status: Active	DDCM			X										
33	All Remote Door Lock Command: Unlock	DDCM					X								



SCP Message Matrix

No.	Message Name	Source	Receivers													
			ADCM	PBCM	RECM	GECM	IC	NCM	AUDIO	DDCM	DSCM	SCLCM				
34	All Remote Door Lock Command: Lock	DDCM				X	X									
35	All Reverse Lamp Command: OFF	IC		X												
36	All Reverse Lamp Command: ON	IC		X												
37	ALL Super / Double Door Lock Command: Lock(ed)	DDCM			X											
38	ALL Turn Lamp Command: OFF	GECM			X											
39	ALL Turn Lamp Command: OFF	IC			X		X									
40	ALL Turn Lamp Command: ON	GECM			X											
41	ALL Turn Lamp Command: ON	IC			X		X									
42	Anti-Lock Brake System Active Status: No	IC														
43	Anti-Lock Brake System Active Status Yes	IC			X											
44	Backlighting Intensity and Dimming Curve with Headlamps Command: OFF	IC				X				X						
45	Backlighting Intensity and Dimming Curve with Headlamps Command: ON	IC				X				X						
46	Battery Saver Command: OFF	GECM			X			X								
47	Battery Saver Command: ON	GECM			X			X								
48	Brake Lamp Pedal Switch Status: Active	RECM	X				X									
49	Brake Lamp Pedal Switch Status: Inactive	RECM	X				X									
50	Cellular CPCM In Use Status: No (False)	AUDIO						X								
51	Cellular CPCM In Use Status: Yes (True)	AUDIO						X								
52	Chime Configuration 1 Command: Enable(d)	GECM						X								
53	Console Door Lock Cylinder State Status	RECM									X					
54	Decklid Door Ajar Switch Status: Active	RECM					X	X				X				
55	Decklid Door Ajar Switch Status: Inactive	RECM					X	X				X				
56	Decklid Door Open Command: Yes (True)	GECM			X											
57	Delayed Accessory Command: OFF	DDCM			X											
58	Delayed Accessory Command: ON	DDCM			X											
59	Display Access Confirmation Status: Accept	IC									X					
60	Display Access Confirmation Status: Reject	IC									X		X			
61	Display Access String Command: Clear Display	AUDIO						X								
62	Display Access String Command: Clear Display	NCM						X								
63	Display Access String Command: Overwrite Display	AUDIO						X								
64	Display Access String Command: Overwrite Display	NCM						X								
65	Display Access Terminate Command	AUDIO						X								



SCP Message Matrix

No.	Message Name	Source	Receivers													
			ADCM	PBCM	RECM	GECCM	IC	NCM	AUDIO	DDCM	DSCM	SCLCM				
66	Display Access Terminate Command	NCM						X								
67	Download Block to Display Command	AUDIO						X								
68	Download Block to Display Command	NCM						X								
69	Driver's Front Door Ajar Switch Status: Active	GECCM			X			X		X						
70	Driver's Front Door Ajar Switch Status: Inactive	GECCM			X			X		X						
71	Driver's Front Door Lock Cylinder State Status	DDCM				X		X								
72	Driver's Front Door Lock Switch Status: Active	DDCM				X										
73	Driver's Front Door Unlock Switch Status: Active	DDCM				X										
74	Driver's Rear Door Ajar Switch Status: Active	RECM				X		X		X						
75	Driver's Rear Door Ajar Switch Status: Inactive	RECM				X		X		X						
76	Engine Oil Fluid Pressure Low Status: No (False)	GECCM						X								
77	Engine Oil Fluid Pressure Low Status: Yes (True)	GECCM						X								
78	Engine RPM with High Resolution Rate-of-Change with Throttle Position Status	IC		X			X									
79	Electronic Park Brake Fault Status	PBCM						X								
80	Electronic Park Brake mode	PBCM			X			X								
81	Front Windshield Wiper Mode Status	GECCM						X								
82	Fuel Input / Output Status	RECM						X								
83	Fuel Level: Sensor Analog / Digital Output Status	RECM						X								
84	Gateway A/CCM to Display	IC								X						
85	Gateway A/CCM to VACM	IC									X					
86	Gateway Audio to NCM	AUDIO								X						
87	Gateway Audio to NCM (Multiframe)	AUDIO								X						
88	Gateway Telematics Display to A/CCM	NCM						X								
89	Gateway NCM to Audio	NCM									X					
90	Gateway NCM to CPCM (AT CMD) (first frame)	NCM									X					
91	Gateway NCM to CPCM (AT CMD) (continuation frame)	NCM									X					
92	Gateway NCM to CPCM (D2B OPC) (first frame)	NCM									X					
93	Gateway NCM to CPCM (D2B OPC) (continuation frame)	NCM									X					
94	Gateway NCM to SMS (SMS Data) (first frame)	NCM									X					
95	Gateway NCM to SMS (SMS Data) (continuation frame)	NCM									X					
96	Gateway NCM to VEMS (AT CMD) (first frame)	NCM									X					
97	Gateway NCM to VEMS (AT CMD) (continuation frame)	NCM									X					



SCP Message Matrix

No.	Message Name	Source	Receivers												
			ADCM	PBCM	RECM	GECM	IC	NCM	AUDIO	DDCM	DSCM	SCLCM			
98	Gateway NCM to VEMS (D2B) (first frame)	NCM									X				
99	Gateway NCM to VEMS (D2B) (continuation frame)	NCM									X				
100	Gateway NCM to VACM	NCM									X				
101	Gateway CPCM to NCM (AT CMD) (first frame)	AUDIO										X			
102	Gateway CPCM to NCM (AT CMD) (continuation frame)	AUDIO										X			
103	Gateway CPCM to NCM (D2B OPC) (first frame)	AUDIO										X			
104	Gateway CPCM to NCM (D2B OPC) (continuation frame)	AUDIO										X			
105	Gateway SMS to NCM (SMS Data) (first frame)	AUDIO										X			
106	Gateway SMS to NCM (SMS Data) (continuation frame)	AUDIO										X			
107	Gateway VEMS to NCM (AT CMD) (first frame)	AUDIO										X			
108	Gateway VEMS to NCM (AT CMD) (continuation frame)	AUDIO										X			
109	Gateway VEMS to NCM (D2B OPC) (first frame)	AUDIO										X			
110	Gateway VEMS to NCM (D2B OPC) (continuation frame)	AUDIO										X			
111	Gateway VACM to A/CCM	AUDIO							X						
112	Gateway VACM to NCM	AUDIO										X			
116	Hood Door Ajar Switch Status: Active	GECM							X				X		
117	Hood Door Ajar Switch Status: Inactive	GECM							X				X		
118	Horn Configuration 1 Command: Disabled	IC						X							
119	Horn Configuration 1 Command: Enabled	IC						X							
120	Horn Configuration 3 Command: Enabled	DDCM						X							
121	Ignition Switch Position with Initialize Status: No (False)	IC		X	X	X	X	X				X	X	X	
122	Ignition Switch Position with Initialize Status: Yes (True)	IC		X	X	X	X	X				X	X	X	
123	Key-in-Ignition Status: No (False)	IC		X	X	X	X	X				X	X	X	
124	Key-in-Ignition Status: Yes (True)	IC		X	X	X	X	X				X	X	X	
125	Left Front Turn Lamp OK Status: No (False)	GECM								X					
126	Left Front Turn Lamp OK Status: Yes (True)	GECM								X					
127	Left Rear Brake Lamp OK Status: No (False)	RECM								X					
128	Left Rear Brake Lamp OK Status: Yes (True)	RECM								X					
129	Left Rear Tail Lamp OK Status: No (False)	RECM								X					
130	Left Rear Tail Lamp OK Status: Yes (True)	RECM								X					
131	Left Rear Turn Lamp OK Status: No (False)	RECM								X					
132	Left Rear Turn Lamp OK Status: Yes (True)	RECM								X					
133	Left Side-Mid Vehicle Turn Lamp OK Status: No (False)	GECM								X					



SCP Message Matrix

No.	Message Name	Source	Receivers												
			ADCM	PBCM	RECM	GECM	IC	NCM	AUDIO	DDCM	DSCM	SCLCM			
134	Left Side Mid Vehicle Turn Lamp OK Status: Yes (True)	GECM					X								
135	Left Side Turn Signal Turn Lamp Command: OFF	IC			X	X									
136	Left Side Turn Signal Turn Lamp Command: ON	IC			X	X									
137	Low Fuel Level Status: No (False)	IC							X						
138	Low Fuel Level Status: Yes (True)	IC							X						
139	Low Washer Fluid Tell Tale Command: OFF	GECM					X								
140	Low Washer Fluid Tell Tale Command: ON	GECM					X								
141	Memory Feature Menu Status	DDCM				X						X			
142	Memory Feature Menu Status	IC				X						X	X		
143	Memory Features 1 Command: Recall	DDCM				X							X		
144	Memory Features 1 Command: Set / Save	DDCM				X							X		
145	Memory Features 2 Command: Recall	DDCM				X							X		
146	Memory Features 2 Command: Set / Save	DDCM				X							X		
147	Memory Features Recall Cancel Command: Yes (True)	DDCM				X							X		
148	Memory Features Recall Cancel Command: Yes (True)	DSCM				X							X		
149	Memory Features Recall Cancel Command: Yes (True)	IC							X				X		
150	Network Bus Wake-up Command: Yes (True)	PBCM													
151	Network Bus Wake-up Command: Yes (True)	IC													
152	Network Bus Wake-up Command: Yes (True)	DDCM													
153	Network Bus Wake-up Command: Yes (True)	DSCM													
154	Network Bus Wake-up Command: Yes (True)	GECM													
155	Network Bus Wake-up Command: Yes (True)	RECM													
156	Odometer Rolling Count Status	IC								X					
157	Parking Brake Switch Status: Active	PBCM				X					X				
158	Parking Brake Switch Status: Inactive	PBCM				X					X				
159	Passenger's Front Door Ajar Switch Status: Active	GECM					X				X				
160	Passenger's Front Door Ajar Switch Status: Inactive	GECM					X				X				
161	Passenger's Front Door Lock Switch Status: Active	RECM						X							
162	Passenger's Front Door Unlock Switch Status: Active	RECM						X							
163	Passenger's Front Window Open Switch Status: Active	GECM											X		
164	Passenger's Mirror Down Motion Command: Enable(d)	DDCM													
165	Passenger's Mirror Left Motion Command: Disable(d)	DDCM													
166	Passenger's Mirror Left Motion Command: Enable(d)	DDCM													



CAN Message Matrix

No.	Message Name	Source	Receivers													
			ADCM	PBCM	RECM	GECM	IC	NCM	AUDIO	DDCM	DSCM	SCLCM				
167	Passenger's Mirror Right Motion Command: Enabled(d)	DDCM				X										
168	Passenger's Mirror Up Motion Command: Enabled(d)	DDCM				X										
169	Passenger's Rear Door Ajar Switch Status: Active	RECM				X		X				X				
170	Passenger's Rear Door Ajar Switch Status: Inactive	RECM				X		X				X				
171	Passenger's Rear Window Open Switch Status: Active	RECM											X			
172	Pedal Adjustment Status: Disabled	GECM						X								
173	Pedal Adjustment Status: Enabled	GECM						X								
174	Remote control #1 Button status: Button 7 (PTT) Active	AUDIO								X						
175	Remote control #1 Button status: Button 6 (VOL+) Active	AUDIO								X						
176	Remote control #1 Button status: Button 5 (VOL-) Active	AUDIO								X						
177	Remote control #1 Button status: Button 4 (SELECT) Active	AUDIO								X						
178	Remote control #1 Button status: Button 3 (SEEK UP) Active	AUDIO								X						
179	Remote control #1 Button status: Button 2 (SEEK DOWN) Active	AUDIO								X						
180	Remote control #1 Button status: Button Inactive	AUDIO								X						
181	Rear Windshield Electric Defrost Status: OFF	RECM								X						
182	Rear Windshield Electric Defrost Status: ON	RECM								X						
183	Rear Windshield Electric Defrost Switch Status: Active	IC						X								
184	Rear Windshield Electric Defrost Switch Status: Inactive	IC						X								
185	Remote Panic Button Status: Active	DDCM					X									
186	Request All Courtesy Lamp Status	IC					X									
187	Request All Courtesy Lamp Switch Status	GECM						X								
188	Request All Remote Door Lock with Transmitter Id Status	AUDIO										X				
189	Request All Front Fog Lamp Command	GECM							X							
190	Request All Front Fog Lamp Status	IC							X							
191	Request All Front High Beam Lamp Command	GECM								X						
192	Request All Front High Beam Lamp Status	IC							X							
193	Request All Headlamp Command	GECM														
194	Request All Headlamp Status	IC								X						
195	Request All Park Lamp Command	AUDIO								X						
196	Request All Park Lamp Command	GECM														
197	Request All Park Lamp Command	RECM														
198	Request All Rear Brake Lamp Command	RECM														
199	Request All Rear Fog Lamp Command	RECM														



SCP Message Matrix

No.	Message Name	Source	Receivers												
			ADCM	PBCM	RECM	GECM	IC	NCM	AUDIO	DDCM	DSCM	SCLCM			
200	Request All Rear Fog Lamp Status	IC			X										
201	Request All Rear Park Lamp Command	RECM				X									
202	Request All Rear Window Lockout Switch Status	RECM									X				
203	Request Anti-Lock Brake System Active Status	PBCM						X							
204	Request Backlighting Intensity and Dimming Curve with Headlamps Command	GECM						X							
205	Request Backlighting Intensity and Dimming Curve with Headlamps Command	NCM						X							
206	Request Battery Saver Command	IC					X								
207	Request Battery Saver Command	RECM					X								
208	Request Brake Lamp Pedal Switch Status	PBCM				X									
209	Request Brake Lamp Pedal Switch Status	GECM				X									
210	Request Brake Lamp Pedal Switch Status	ADCM				X									
211	Request Decklid Door Ajar Switch Status	DDCM				X									
212	Request Decklid Door Ajar Switch Status	GECM				X									
213	Request Decklid Door Ajar Switch Status	IC				X									
214	Request Delayed Accessory Command	GECM									X				
215	Request Delayed Accessory Command	RECM									X				
216	Request Driver's Front Door Ajar Switch Status	DDCM					X								
217	Request Driver's Front Door Ajar Switch Status	IC					X								
218	Request Driver's Front Door Ajar Switch Status	AUDIO					X								
219	Request Driver's Front Door Ajar Switch Status	RECM						X							
220	Request Driver's Rear Door Ajar Switch Status	IC						X							
221	Request Driver's Rear Door Ajar Switch Status	DDCM					X								
222	Request Driver's Rear Door Ajar Switch Status	GECM					X								
223	Request Driver's Rear Door Ajar Switch Status	AUDIO						X							
224	Request PBCM mode	RECM						X							
225	Request PBCM mode	IC						X							
226	Request Front Windshield Wiper Mode Status	IC							X						
227	Request Fuel Input / Output Status	IC						X							
228	Request Generic Vehicle Security ID message	SCLCM								X					
229	Request Hood Door Ajar Switch Status	IC						X							
230	Request Hood Door Ajar Switch Status	DDCM						X							
231	Request Ignition Switch Position with Initialize Status	PBCM								X					



SCP Message Matrix

No.	Message Name	Source	Receivers												
			ADCM	PBCM	RECM	GECM	IC	NCM	AUDIO	DDCM	DSCM	SCLCM			
232	Request Ignition Switch Position with Initialize Status	DDCM					X								
233	Request Ignition Switch Position with Initialize Status	DSCM					X								
234	Request Ignition Switch Position with Initialize Status	GECM					X								
235	Request Ignition Switch Position with Initialize Status	NCM					X								
236	Request Ignition Switch Position with Initialize Status	RECM					X								
237	Request Ignition Switch Position with Initialize Status	AUDIO					X								
238	Request Key-in-Ignition Status	PBCM					X								
239	Request Key-in-Ignition Status	DDCM					X								
240	Request Key-in-Ignition Status	DSCM					X								
241	Request Key-in-Ignition Status	GECM					X								
242	Request Key-in-Ignition Status	RECM					X								
243	Request Left Front Turn Lamp OK Status	IC					X								
244	Request Left Rear Brake Lamp OK Status	IC			X										
245	Request Left Rear Tail Lamp OK Status	IC			X										
246	Request Left Rear Turn Lamp OK Status	IC			X										
247	Request Left Side Mid Vehicle Turn Lamp OK Status	IC					X								
248	Request Low Fuel Level Status	NCM						X							
249	Request Low Washer Fluid Telltale Command	IC					X								
250	Request Memory Feature Menu Status	DSCM							X						
251	Request Memory Feature Menu Status	GECM							X						
252	Request Parking Brake Switch Status	DDCM		X											
253	Request Parking Brake Switch Status	AUDIO		X											
254	Request Parking Brake Switch Status	GECM		X											
255	Request Passenger's Front Door Ajar Switch Status	DDCM					X								
256	Request Passenger's Front Door Ajar Switch Status	IC					X								
257	Request Passenger's Front Door Ajar Switch Status	AUDIO					X								
258	Request Passenger's Front Door Ajar Switch Status	RECM					X								
259	Request Passenger's Rear Door Ajar Switch Status	DDCM			X										
260	Request Passenger's Rear Door Ajar Switch Status	GECM			X										
261	Request Passenger's Rear Door Ajar Switch Status	IC			X										
262	Request Passenger's Rear Door Ajar Switch Status	AUDIO			X										
263	Request Rear Windshield Electric Defrost Switch Status	RECM													
264	Request Right Front Turn Lamp OK Status	IC					X								



SCP Message Matrix

No.	Message Name	Source	Receivers																	
			ADCM	PBCM	RECM	GECM	IC	NCM	AUDIO	DDCM	DSCM	SCLCM								
265	Request Right Rear Brake Lamp OK Status	IC			X															
266	Request Right Rear Tail Lamp OK Status	IC			X															
267	Request Right Rear Turn Lamp OK Status	IC			X															
268	Request Right Side Mid Vehicle Turn Lamp OK Status	IC					X													
269	Request Steering Column Lock System Status	IC																		X
275	Request Vehicle Speed Control Active Status	GECM						X												
276	Right Front Turn Lamp OK Status: No (False)	GECM						X												
277	Right Front Turn Lamp OK Status: Yes (True)	GECM						X												
278	Right Rear Brake Lamp OK Status: No (False)	RECM						X												
279	Right Rear Brake Lamp OK Status: Yes (True)	RECM						X												
280	Right Rear Tail Lamp OK Status: No (False)	RECM						X												
281	Right Rear Tail Lamp OK Status: Yes (True)	RECM						X												
282	Right Rear Turn Lamp OK Status: No (False)	RECM						X												
283	Right Rear Turn Lamp OK Status: Yes (True)	RECM						X												
284	Right Side Mid Vehicle Turn Lamp OK Status: No (False)	GECM						X												
285	Right Side Mid Vehicle Turn Lamp OK Status: Yes (True)	GECM						X												
286	Right Side Turn Signal Turn Lamp Command: OFF	IC					X		X											X
287	Right Side Turn Signal Turn Lamp Command: ON	IC					X		X											X
288	Steering Column Lock Command: Lock	IC																		
289	Steering Column Lock Command: Unlock	IC																		
290	Steering Column Lock Enable Command: OFF	IC					X		X											
291	Steering Column Lock Enable Command: ON	IC					X		X											
292	Steering Column Lock Enable Status: OFF	GECM								X										
293	Steering Column Lock Enable Status: OFF	RECM								X										
294	Steering Column Lock Enable Status: ON	GECM								X										
295	Steering Column Lock Enable Status: ON	RECM								X										
296	Steering Column Lock System Status	SCLCM								X										
297	Suspension System State Status	ADCM								X										
298	Terminate Display Confirmation Status: Accept	IC									X				X					
299	Terminate Display Confirmation Status: Reject	IC									X				X					
300	Terminate Display Definition Command	AUDIO								X										
301	Terminate Display Definition Command	NCM								X										
302	Time of Day (with Mode) Command	NCM													X					



SCP Message Matrix

No.	Message Name	Source	Receivers												
			ADCM	PBCM	RECM	GECM	IC	NCM	AUDIO	DDCM	DSCM	SCLCM			
303	Time of Day (with Mode) Status	AUDIO								X		X			
304	Transmission PRNDL Range Selected Status	IC		X	X								X		
306	Vehicle Configuration Module Programmed Status: No (False)	AUDIO						X							
309	Vehicle Speed Control Active Status: No (False)	IC					X								
310	Vehicle Speed Control Active Status: Yes (True)	IC					X								
311	Vehicle Speed: Driven and Undriven Wheels: High Resolution	IC	X	X	X							X	X		
312	VACM Control Mode Status: OFF	AUDIO								X					
313	VACM Control Mode Status: ON	AUDIO								X					
314	VACM training mode entry	NCM										X			



CAN Message Matrix

Message Name	Source	Receivers												
		DSCCM	ECM	TCM	A/CCM	IC	ASCCM	HLCM	JGM	DIAG				
CAN FLASH PROGRAM WDS ECM	DIAG		X											
CAN FLASH PROGRAM WDS TCM	DIAG			X										
CAN FLASH PROGRAM ECM WDS	ECM													X
CAN FLASH PROGRAM TCM WDS	TCM													X
CAN IGNITION OFF TIMER	IC		X											
CAN ENGINE TORQUE REQUEST	DSCCM		X											
CAN TEMPORARY TORQUE REQUEST	DSCCM		X											
CAN ENGINE DRAG TORQUE REQUEST	DSCCM		X											
CAN BRAKE LINE PRESSURE	DSCCM			X										
CAN YAW RATE SIGNAL	DSCCM								X					
CAN LATERAL ACCELERATION SIGNAL	DSCCM									X				
CAN STEERING WHEEL ANGLE	DSCCM					X								
CAN STEERING WHEEL SPEED	DSCCM									X				
CAN INDICATED ENGINE TORQUE	ECM	X												
CAN ENGINE FRICTION TORQUE	ECM	X												
CAN ACTUAL ENGINE TORQUE	ECM	X												
CAN DRIVER DEMAND TORQUE	ECM	X												
CAN TORQUE REDUCTION REQUEST	TCM		X											
CAN TRANSMISSION TORQUE LIMIT	TCM		X											
CAN TORQUE CONVERTER SLIP	TCM	X												
CAN TRANSMISSION INPUT SPEED	TCM		X											
CAN TRANSMISSION OUTPUT SPEED	TCM		X											
CAN DSC CONFIGURATION	DSCCM										X			
CAN VEHICLE REFERENCE SPEED	DSCCM		X									X		
CAN DSC FAULT CODES	DSCCM		X											
CAN ODO ROLLING COUNT	DSCCM									X				
CAN DSC MALFUNCTION	DSCCM		X									X		
CAN OBDII DSC CLEAR ACKNOWLEDGE	DSCCM		X											
CAN DSC FAULT CODE MIL STATUS	DSCCM		X											
CAN DSC STATUS	DSCCM											X		
CAN TRACTION SHIFT MAP	DSCCM												X	
CAN TCS ENGINE TORQUE CONTROL	DSCCM		X										X	
CAN TCS BRAKE CONTROL	DSCCM		X										X	



CAN Message Matrix

Message Name	Source	Receivers												
		DSCCM	ECM	TCM	A/CCM	IC	ASCCM	HLCM	JGM	DIAG				
CAN YAW CONTROL	DSCCM		X							X				
CAN TCS SWITCH STATUS	DSCCM		X	X						X				
CAN TRANSMISSION INPUT INDICATED TORQUE	ECM	X		X										
CAN ENGINE ACCELERATION	ECM	X												
CAN THROTTLE POSITION	ECM			X										
CAN PEDAL POSITION	ECM	X		X							X			
CAN ENGINE SPEED	ECM	X		X			X			X				
CAN ALTERNATOR STATUS	ECM								X					
CAN CRUISE STATUS	ECM			X					X		X			
CAN KICKDOWN	ECM			X										
CAN OBDII CLEAR FAULT CODES	ECM	X		X										
CAN BRAKE PEDAL PRESSED	ECM	X		X							X	X		
CAN CRANK IN PROGRESS	ECM	X		X					X		X		X	
CAN TRACTION ACKNOWLEDGE	ECM	X												
CAN FUEL CAP WARNING	ECM									X				
CAN ASC DISPLAY COMMANDS	ASCCM									X				
CAN HEADWAY SETTING	ASCCM									X				
CAN FOLLOW WARNING LIGHT	ASCCM									X				
CAN DISPLAY SET SPEED	ASCCM									X				
CAN FOLLOW SPEED	ASCCM													
CAN BRAKE DEMAND PRESSURE	ASCCM	X												
CAN ASC STATUS	ASCCM	X								X				
CAN ASC CONFIG FLAG	ASCCM									X				
CAN ACTIVE BRAKE BOOSTER ENABLE	ASCCM	X												
CAN ASC SPARE														
CAN SET SPEED	ECM			X								X		
CAN TARGET SPEED	ECM											X		
CAN ECM ASC FAIL	ECM											X		
CAN HEADWAY INCREMENT	ECM											X		
CAN CANCEL REQUEST	ECM											X		
CAN BRAKE ACTUAL PRESSURE	DSCCM							X					X	
CAN BRAKE DEMAND PRESSURE ACKNOWLEDGE	DSCCM												X	
CAN ACTIVE BRAKE BOOSTER STATUS	DSCCM												X	



CAN Message Matrix

Message Name	Source	Receivers												
		DSCCM	ECM	TCM	A/CCM	IC	ASCCM	HLCM	JGM	DIAG				
CAN PARKBRAKE STATUS	IC		X	X						X				
CAN DIPPED BEAM STATUS	IC		X								X			
CAN REVERSE GEAR MANUAL SELECTED	IC		X											
CAN RESTRICTED A/C BLOWERS	IC				X									
CAN FUEL LEVEL DAMPED	IC		X											
CAN FUEL LEVEL RAW 1	IC		X											
CAN FUEL LEVEL RAW 2	IC		X											
CAN FUEL PUMP STATUS	IC		X											
CAN INDICATOR RIGHT	IC									X				
CAN INDICATOR LEFT	IC									X				
CAN WIPER STATUS	IC									X				
CAN NATURAL LIGHT	IC									X				
CAN TRIP UNITS	IC		X							X				
CAN IC ASC ENABLE	IC		X							X				
CAN BACKLIGHT STATUS	IC									X				
CAN BACKLIGHT INTENSITY	IC									X				
CAN J GATE POSITION SELECTED	JGM			X										
CAN INTERMEDIATE POSITION FAULT	JGM			X										
CAN J GATE FAULT	JGM		X	X										
CAN PERFORMANCE MODE SWITCH	JGM			X										
CAN GEAR POSITION ACTUAL	TCM	X												
CAN GEAR POSITION SELECTED	TCM		X						X				X	
CAN TRANSMISSION SHIFT MAP	TCM		X							X				
CAN TRANSMISSION FLUID TEMPERATURE	TCM		X						X					
CAN TRANSMISSION MALFUNCTION	TCM		X						X					
CAN TORQUE CONVERTER STATUS	TCM		X											
CAN GEAR SELECTION FAULT	TCM		X										X	
CAN IDLE NEUTRAL CONTROL	TCM		X											
CAN PERFORMANCE MODE INDICATION	TCM													X
CAN TCM FAULT CODE MIL STATUS	TCM		X											
CAN OBDII TCM CLEAR ACKNOWLEDGE	TCM		X											
CAN TRANSMISSION FAULT CODES	TCM		X											
CAN GEAR POSITION TARGET	TCM	X	X											



CAN Message Matrix

Message Name	Source	Receivers												
		DSCCM	ECM	TCM	A/CCM	IC	ASCCM	HLCM	JGM	DIAG				
CAN J GATE SELECTION FAULT	TCM		X										X	
CAN TORQUE CONV MULT	TCM	X												
CAN PRESSURE TRANSDUCER	ECM				X									
CAN ENGINE INTAKE TEMPERATURE	ECM				X									
CAN A/C CLUTCH INHIBIT STATUS	ECM				X									
CAN ELECTRICAL LOAD MANAGEMENT	ECM				X									
CAN A/C LOAD CONTROL	ECM				X									
CAN COOLING FAN FEEDBACK	ECM				X									
CAN AMBIENT TEMPERATURE	A/CCM		X	X										
CAN COMPRESSOR TORQUE	A/CCM		X											
CAN A/C COMMANDS	A/CCM		X											
CAN A/C STATUS	A/CCM		X						X					
CAN COOLING FAN REQUEST	A/CCM		X											
CAN EVAPORATING TEMPERATURE	A/CCM		X											
CAN FUEL USED	ECM								X					
CAN ENGINE OBDII MIL	ECM								X					
CAN THROTTLE MALFUNCTION RED	ECM								X					
CAN THROTTLE MALFUNCTION AMBER	ECM								X					
CAN ECM FAULT CODE MIL STATUS	ECM			X										
CAN ENGINE FAULT CODES	ECM													
CAN ENGINE COOLANT TEMPERATURE	ECM			X	X									
CAN ENGINE OIL TEMPERATURE	ECM			X										
CAN BAROMETRIC PRESSURE	ECM			X										
CAN FL WHEEL SPEED	DSCCM		X	X							X	X		
CAN FR WHEEL SPEED	DSCCM		X	X							X	X		
CAN RL WHEEL SPEED	DSCCM		X	X							X	X		
CAN RR WHEEL SPEED	DSCCM		X	X							X	X		
CAN DRIVEN WHEEL SPEED	DSCCM								X					
CAN UNDRIVEN WHEEL SPEED	DSCCM								X					
CAN WHEEL SPEED SENSOR FAULT	DSCCM								X					
CAN ODOMETER READING	IC		X	X										
CAN VOICE AIRCON COMMAND	IC							X						
CAN AIRCON VOICE STATUS	A/CCM									X				



CAN Message Matrix

Message Name	Source	Receivers												
		DSCCM	ECM	TCM	A/CCM	IC	ASCCM	HLCM	JGM	DIAG				
CAN DISPLAY AIRCON COMMAND					X									
CAN AIRCON DISPLAY STATUS	A/CCM					X								
CAN POWERTRAIN CONFIGURATION	ECM	X		X										
CAN ECM DEVAID	ECM												X	
CAN DIAGNOSTIC DATA IN ASCCM	DIAG										X			
CAN DIAGNOSTIC DATA OUT ASCCM	ASCCM													X
CAN DIAGNOSTIC DATA IN A/CCM	DIAG						X							
CAN DIAGNOSTIC DATA OUT A/CCM	A/CCM													X
CAN DIAGNOSTIC DATA IN ECM	DIAG		X											
CAN DIAGNOSTIC DATA IN TCM	DIAG			X										
CAN DIAGNOSTIC DATA IN IC	DIAG								X					
CAN DIAGNOSTIC DATA IN DSCCM	DIAG	X												
CAN DIAGNOSTIC DATA OUT ECM	ECM													X
CAN DIAGNOSTIC DATA OUT TCM	TCM													X
CAN DIAGNOSTIC DATA OUT IC	IC													X
CAN DIAGNOSTIC DATA OUT DSCCM	DSCCM													X