



XJ range

DATE 09/05

XJ310-04

**SERVICE**

## **TECHNICAL BULLETIN**

**Fuel Filler Flap Will Not Open/Close –  
Release Spring Out Of Position –  
Install Modified Release Cable**

MODEL 2004-05 MY  
XJ range

VIN G00442-G40857

**Issue:**

Some 2004 MY XJ range vehicles may exhibit an inoperable fuel filler flap. This can be caused by the release spring coming out of position.

**Action:**

In case of a verified customer complaint of the above condition, install a new modified fuel filler flap release cable as outlined below.

**Note:** Check for bad electrical connections and that the fuel filler flap cable is installed correctly. Any faults found must be carried out as a separate Warranty claim. This Technical Bulletin **only** applies to the replacement of the fuel filler flap cable.

REMOVAL

1. Remove the Rear Electronic Module (REM) and position aside (see Global Technical Reference GTR Workshop Manual, section: 419-10).

**NOTE: THE INFORMATION IN TECHNICAL BULLETINS IS INTENDED FOR USE BY TRAINED, PROFESSIONAL TECHNICIANS WITH THE KNOWLEDGE, TOOLS, AND EQUIPMENT TO DO THE JOB PROPERLY AND SAFELY. IT INFORMS THESE TECHNICIANS OF CONDITIONS THAT MAY OCCUR ON SOME VEHICLES, OR PROVIDES INFORMATION THAT COULD ASSIST IN PROPER VEHICLE SERVICE. THE PROCEDURES SHOULD NOT BE PERFORMED BY "DO-IT-YOURSELFERS." DO NOT ASSUME THAT A CONDITION DESCRIBED AFFECTS YOUR CAR. CONTACT A JAGUAR DEALER TO DETERMINE WHETHER THE BULLETIN APPLIES TO YOUR VEHICLE.**

2. Remove the screw securing the fuel filler flap solenoid and disconnect the connector (Illustration 1).

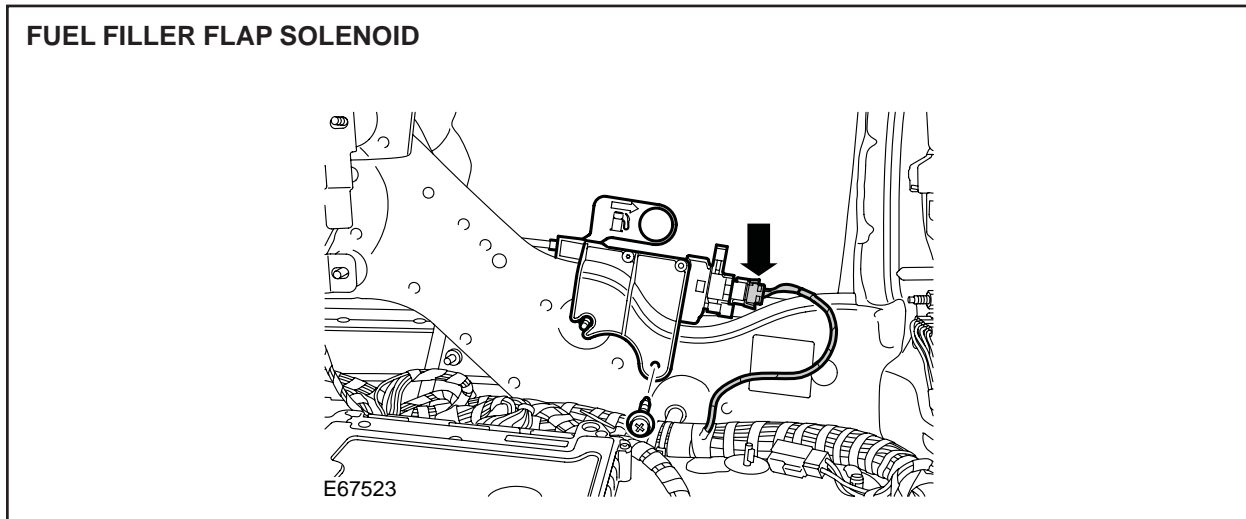

ILLUSTRATION 1

3. Disconnect the fuel filler flap cable from the fuel filler flap solenoid (Illustration 2).

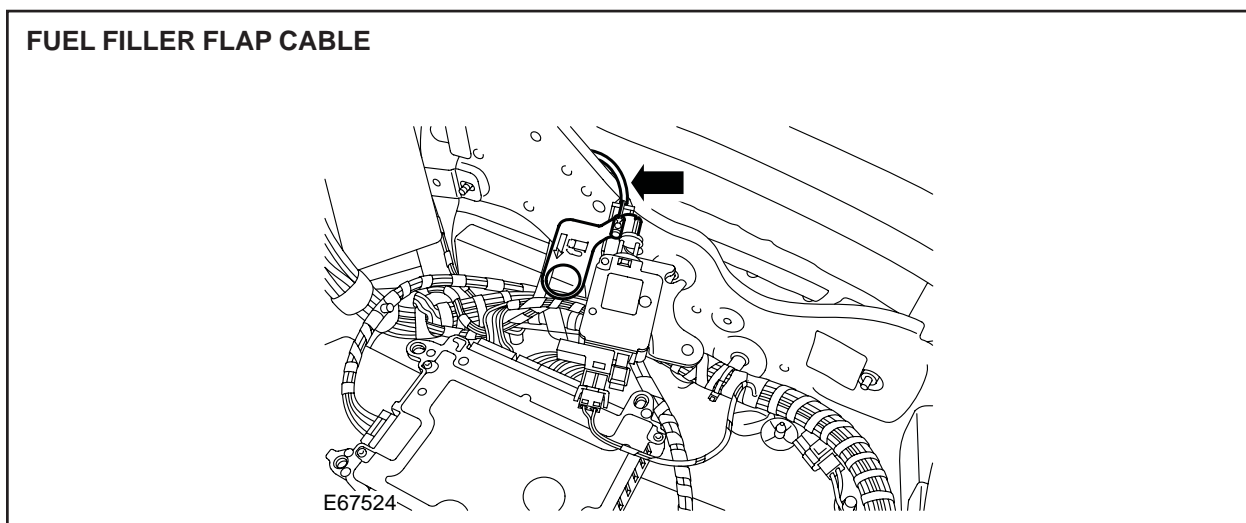

ILLUSTRATION 2

4. Remove the fuel filler cap.

5. Rotate the locking collar clockwise and remove the fuel filler flap cable (Illustration 3).

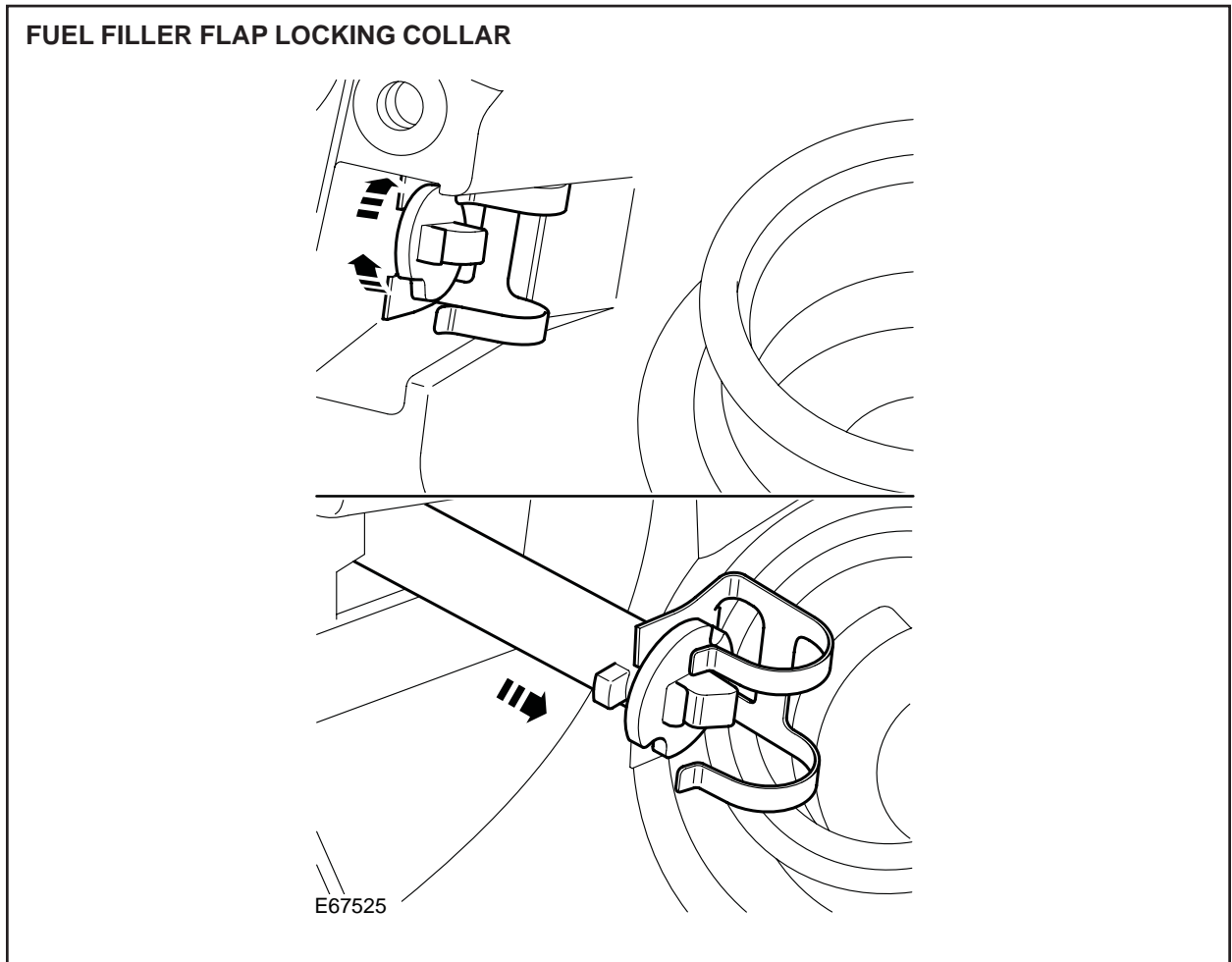

ILLUSTRATION 3

## INSTALLATION

6. Position the new fuel filler flap cable against the fuel filler flap. Align the locking collar to the slots as illustrated.
7. Rotate the locking collar counter clockwise, to secure the fuel filler flap cable.
8. Install the fuel filler cap.
9. Connect the fuel filler flap cable to the fuel filler flap solenoid.
10. Position fuel filler flap solenoid and secure with connector. Install screw and tighten.
11. Check the fuel filler flap for correct operation.
12. Install the REM (see Global Technical Reference GTR Workshop Manual, section: 419-10).

### **Global Technical Reference (GTR) Workshop Manual Information:**

Dealer access: <https://hub.franchise.jaguar.com>

Internet access: <http://www.jaguartechno.com>

### **Parts Information:**

<u>DESCRIPTION</u>	<u>PART NUMBER</u>	<u>QTY</u>
Fuel filler flap release cable	C2C 24614	1

### **Warranty Information:**

Warranty claims should be submitted quoting the information found in the table below. This will result in payment of the stated time and, where applicable parts/miscellaneous expense codes as listed.

<b>Description</b>	<b>SRO</b>	<b>Time</b>	<b>Causal Part Number</b>
Install new fuel filler flap release cable	19.91.77	0.3 hrs.	C2C 24614

**Note:** Repair procedures are under constant review, and therefore repair times are subject to change. The times quoted here must be taken as guidance only. Always refer to DDW to obtain the latest repair time.