



V8 XJ Series/XK

DATE 04/03
Amended 07/04

309-S501

SERVICE

TECHNICAL BULLETIN

Exhaust Gas Recirculation (EGR) Transfer Pipe – Replace – Service Action S501

MODEL 2000-02 MY XKR
2000-01 MY XJR & VDP SC

VIN A00116-A27550
F00103-F30384

Remove and destroy Bulletin 309-S501, dated 4/03.
Replace with this Bulletin.
Revisions are marked with a bar and in **bold text**.

Issue:

A concern has arisen whereby the EGR transfer pipe fitted to vehicles within the above VIN range may crack, due to a combination of normal engine resonance and the form of the pipe. This could result in the illumination of the check engine MIL and customer complaints of excess engine noise.

In order to avoid unnecessary customer inconvenience, the EGR transfer pipe should be replaced with a redesigned EGR transfer pipe on all vehicles within the above VIN range.

Jaguar Cars will be writing to all current owners of vehicles within the above VIN ranges, **who have not had this Service Action performed**, to request them to bring their vehicle in at the first available opportunity to have this work carried out.

Action:

At the next service opportunity, replace the EGR transfer pipe on all 2000-02 MY XKR and 2000-01 MY XJR & VDP SC vehicles within the above VIN range.

NOTE: THE INFORMATION IN TECHNICAL BULLETINS IS INTENDED FOR USE BY TRAINED, PROFESSIONAL TECHNICIANS WITH THE KNOWLEDGE, TOOLS, AND EQUIPMENT TO DO THE JOB PROPERLY AND SAFELY. IT INFORMS THESE TECHNICIANS OF CONDITIONS THAT MAY OCCUR ON SOME VEHICLES, OR PROVIDES INFORMATION THAT COULD ASSIST IN PROPER VEHICLE SERVICE. THE PROCEDURES SHOULD NOT BE PERFORMED BY "DO-IT-YOURSELFERS." DO NOT ASSUME THAT A CONDITION DESCRIBED AFFECTS YOUR CAR. CONTACT A JAGUAR RETAILER TO DETERMINE WHETHER THE BULLETIN APPLIES TO YOUR VEHICLE.



Workshop Procedure - XKR vehicles

On all vehicles

1. Open hood and install fender protectors.
2. Open luggage compartment lid and remove battery cover.
3. Disconnect battery.

Note: Ensure the radio code is available before disconnecting the battery.

4. Remove air intake tube/mass air flow sensor/air cleaner cover assembly (see Illustration 12).

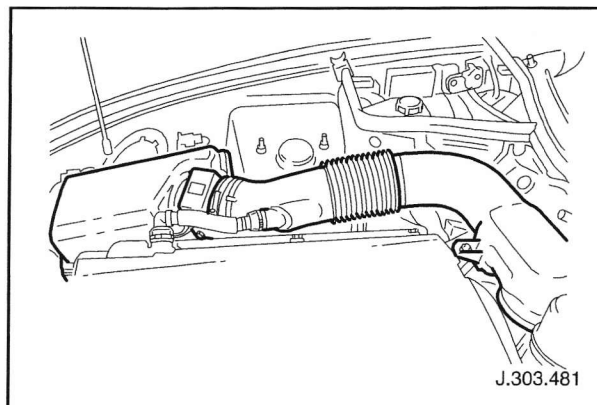

Illustration 12

WARNING: NEVER REMOVE THE COOLANT EXPANSION TANK PRESSURE CAP WHILE THE ENGINE IS RUNNING. WHEN REMOVING THE CAP USE EXTREME CARE TO AVOID HOT COOLANT OR STEAM BLOWING OUT OF THE COOLING SYSTEM. WAIT UNTIL THE ENGINE HAS COOLED DOWN THEN INSULATE THE CAP USING A SUITABLE CLOTH AND SLOWLY LOOSEN THE CAP UNTIL THE PRESSURE IS RELEASED. WHEN ALL THE PRESSURE HAS BEEN RELEASED SLOWLY REMOVE THE CAP FROM THE TANK. FAILURE TO FOLLOW THIS INSTRUCTION MAY RESULT IN PERSONAL INJURY.

5. Release cooling system pressure.
6. Disconnect throttle body electrical connectors (see Illustration 13).

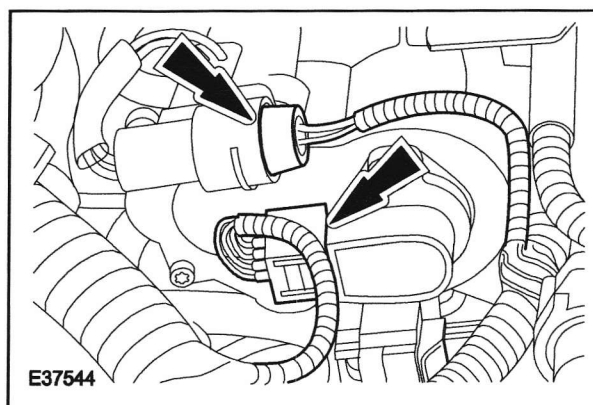

Illustration 13

7. Detach right-hand camshaft position sensor electrical harness (see Illustration 14).

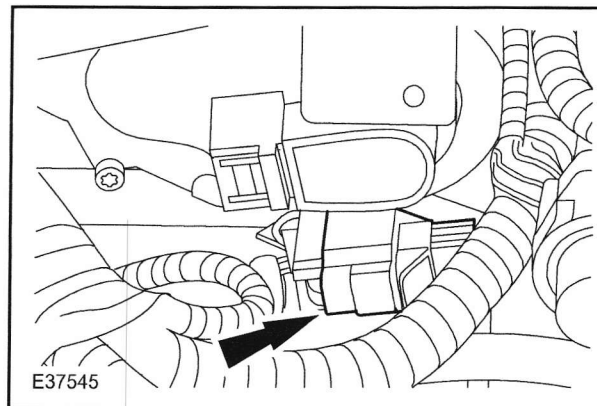

Illustration 14

8. Disconnect throttle body coolant hose (see Illustration 15).

Note: Cap the coolant hose to minimize coolant loss.

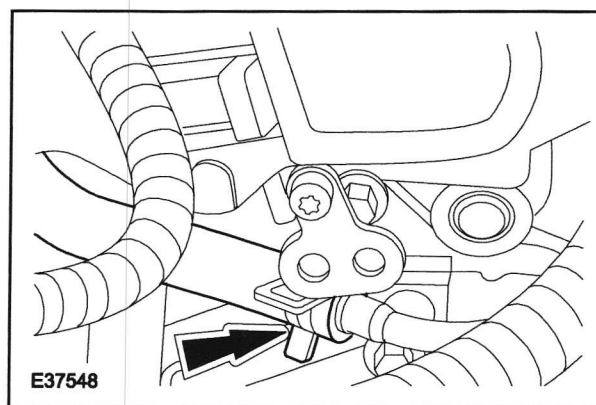

Illustration 15

9. Disconnect throttle body coolant hose (see Illustration 16).

Note: Cap the coolant hose to minimize coolant loss.

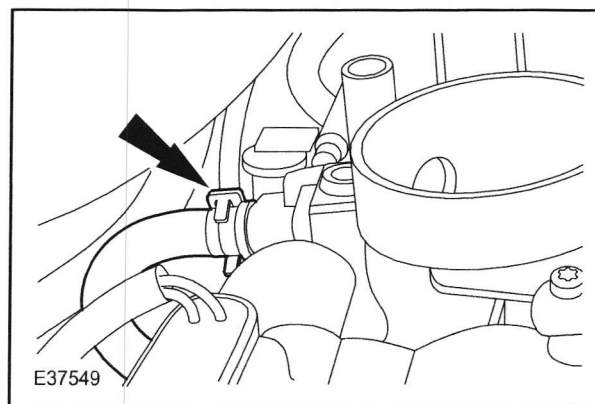

Illustration 16

10. Remove and discard cable tie and disconnect the accelerator outer cable (see Illustration 17).

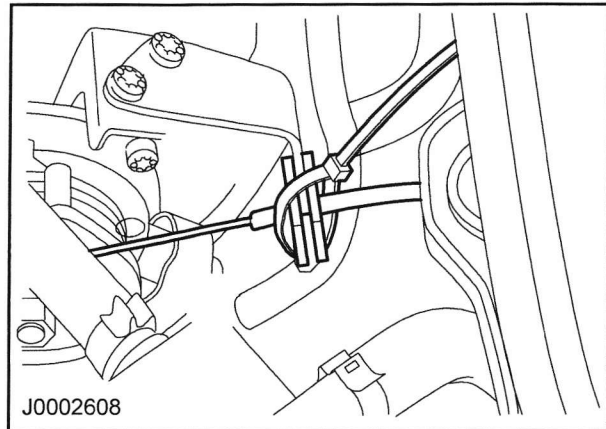

Illustration 17

11. Reposition the accelerator pulley to the full throttle position and disconnect accelerator inner cable (see Illustration 18).

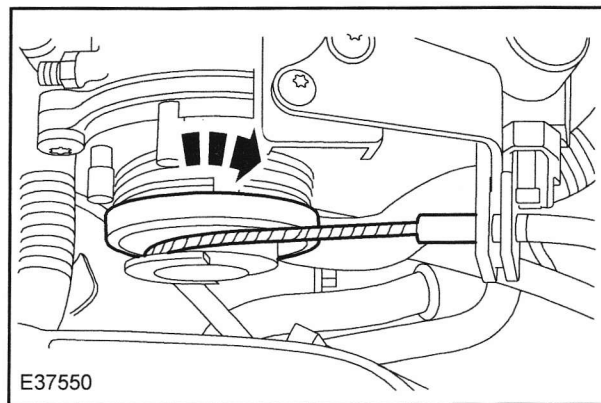

Illustration 18

12. Disconnect throttle body electrical connectors (see Illustration 19).

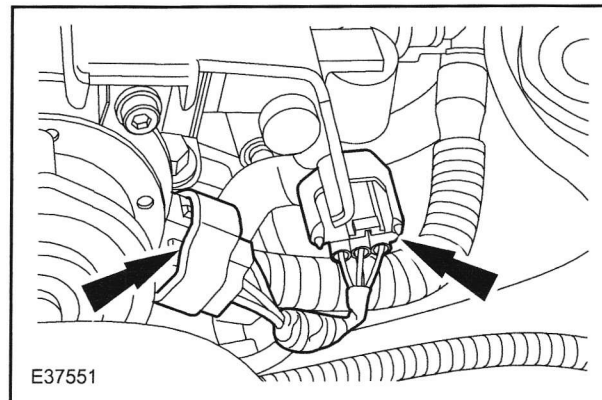

Illustration 19

13. Detach left-hand camshaft position sensor electrical harness (see Illustration 20).

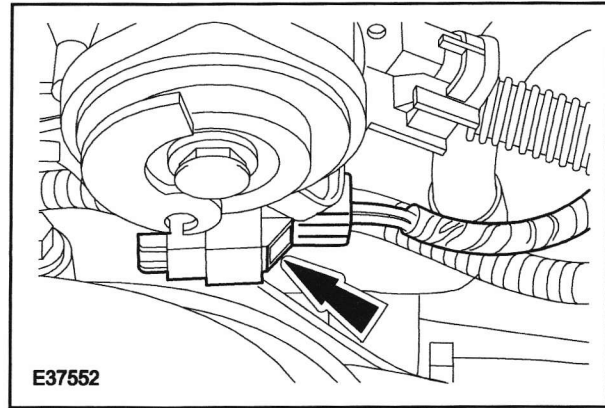

Illustration 20

14. Remove throttle body securing screws and throttle body and discard the gasket (see Illustration 21).

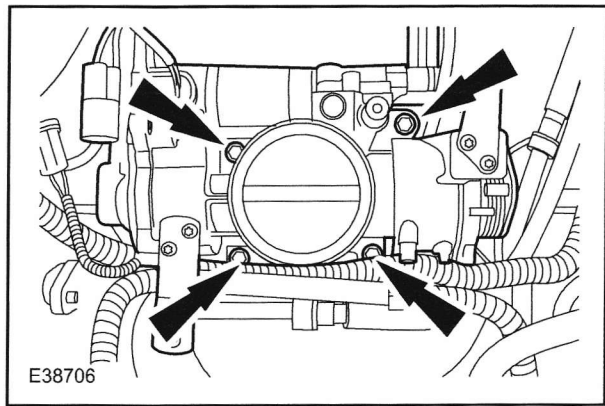

Illustration 21

15. Remove right hand catalytic converter heat shield upper securing screws (see Illustration 22).

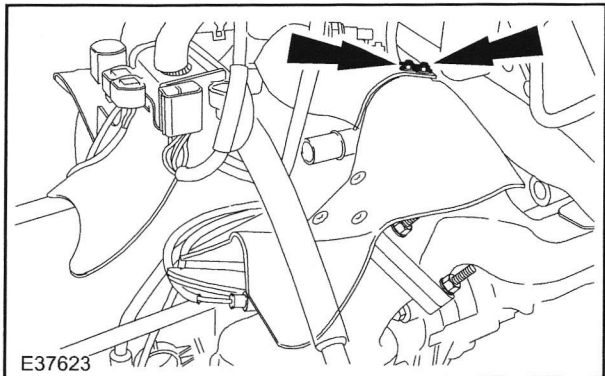

Illustration 22

16. Remove right hand catalytic converter heat shield to right hand exhaust manifold securing screws and remove heat shield from vehicle (see Illustration 23).

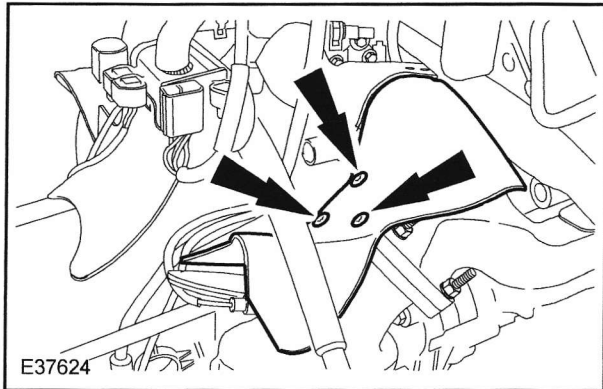

Illustration 23

17. Remove EGR transfer pipe heat shield securing screw and remove heat shield from vehicle (see Illustration 24).

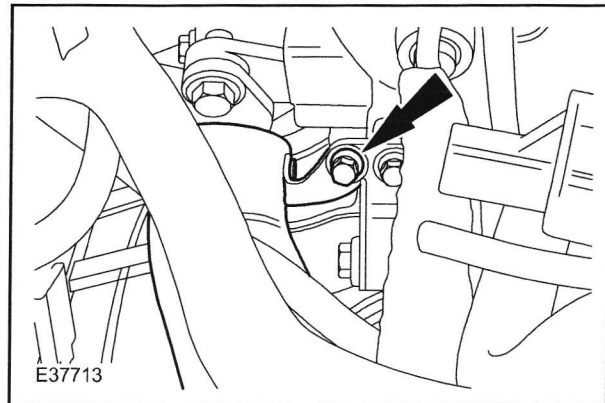

Illustration 24

18. Remove EGR transfer pipe to EGR valve securing screws (see Illustration 25).

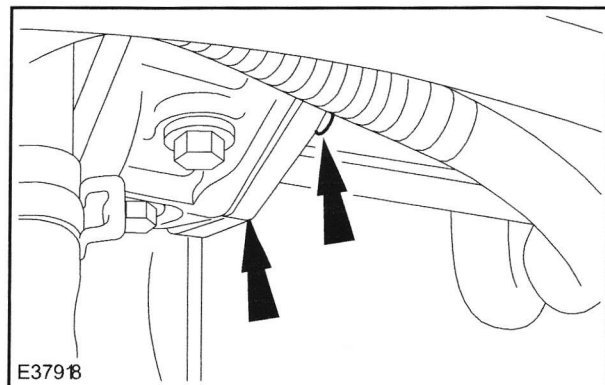

Illustration 25

19. Reposition EGR transfer pipe for access to the gasket.
20. Remove and discard EGR transfer pipe to EGR valve gasket.

21. Remove EGR transfer pipe to right hand exhaust manifold securing nuts (see Illustration 26.).

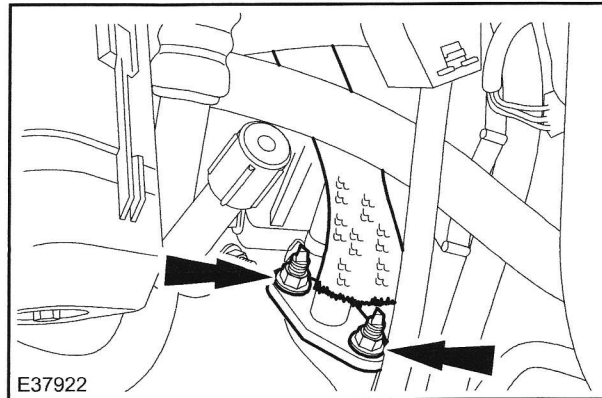

Illustration 26

22. Displace and remove EGR transfer pipe from the right hand exhaust manifold studs.
23. Remove gasket from the right hand exhaust manifold studs.
24. Clean the relevant components and mating faces.
25. Install a new gasket to the right hand exhaust manifold studs.
26. Install EGR transfer pipe to the right hand exhaust manifold studs.
27. Install, but do not fully tighten, EGR transfer pipe to right hand exhaust manifold securing nuts (see Illustration 27).

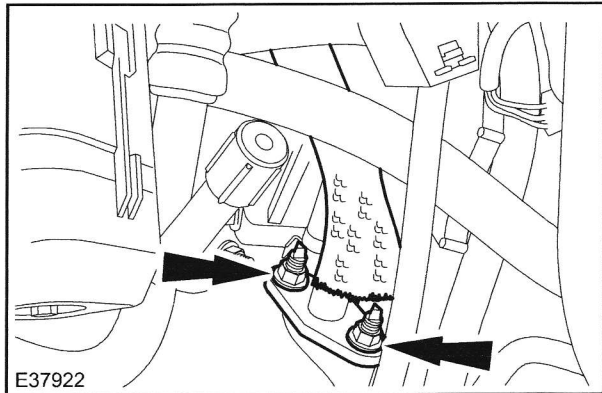

Illustration 27

28. Adjust EGR transfer pipe (via convolutions) to align with the EGR valve.
29. Install a new gasket between the EGR transfer pipe flange and the EGR valve.
30. While maintaining the gasket in position, align the EGR transfer pipe flange to the EGR valve.
31. Install and tighten EGR transfer pipe to EGR valve securing screws to 21Nm (see Illustration 28).

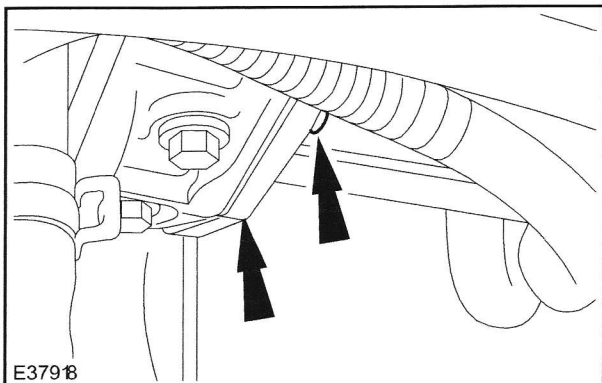

Illustration 28

32. Final tighten EGR transfer pipe to right hand exhaust manifold securing nuts to 21Nm (see Illustration 29).

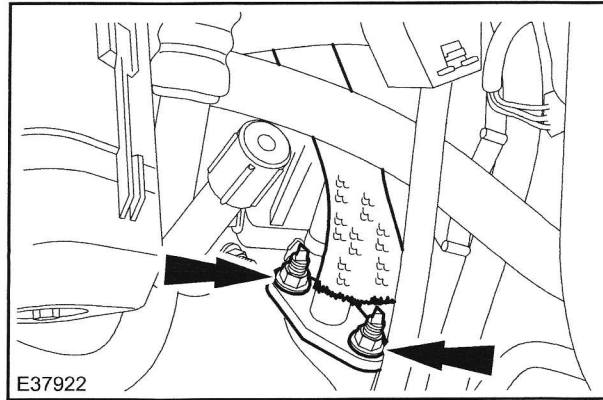

Illustration 29

33. Align EGR transfer pipe heat shield to vehicle and install but do not fully tighten securing screw (see Illustration 30).

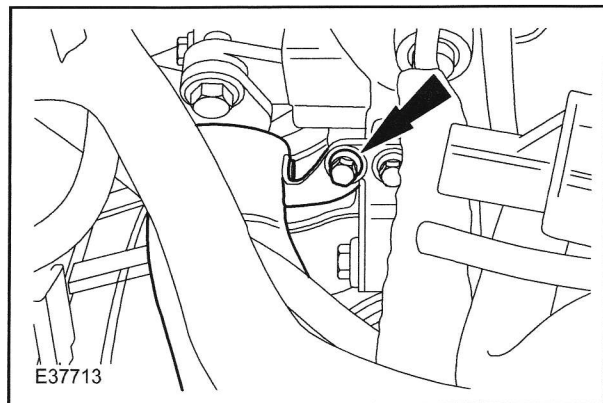

Illustration 30

34. Align right hand catalytic converter heat shield to vehicle and install but do not fully tighten securing screws (see Illustration 31).

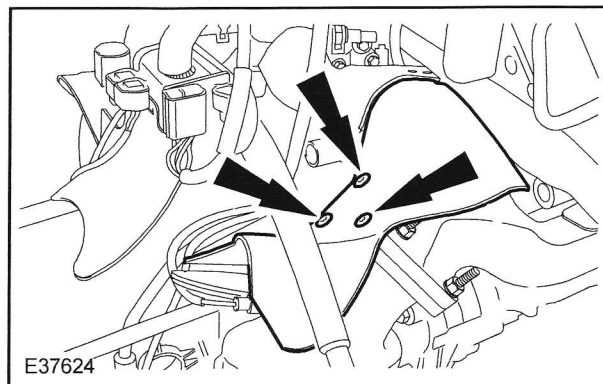

Illustration 31

35. Install and fully tighten right hand catalytic converter heat shield upper securing screws (see Illustration 32).

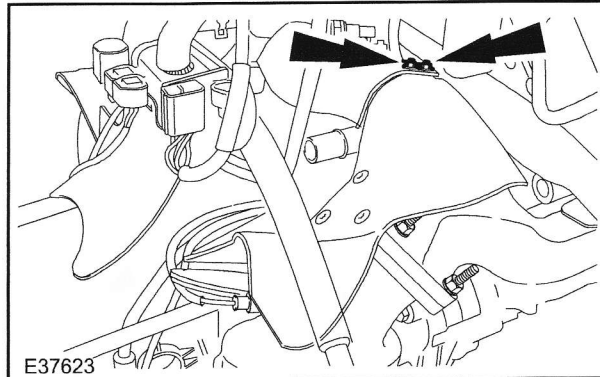

Illustration 32

36. Final tighten EGR and right hand catalytic converter heat shields securing screws.
37. Install a new throttle body gasket and install throttle body. Tighten securing screws to 18-24 Nm (see Illustration 33).

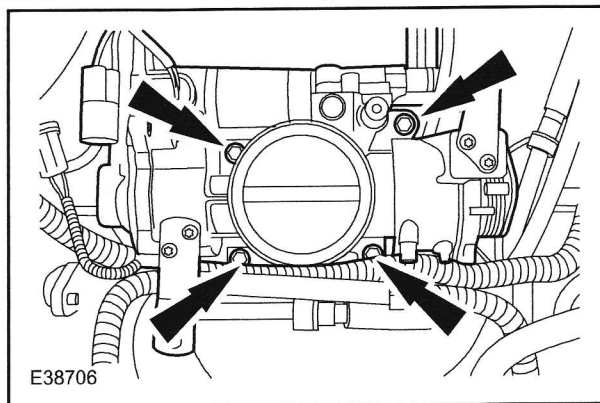

Illustration 33

38. Re-install left-hand camshaft position sensor electrical harness (see Illustration 34).

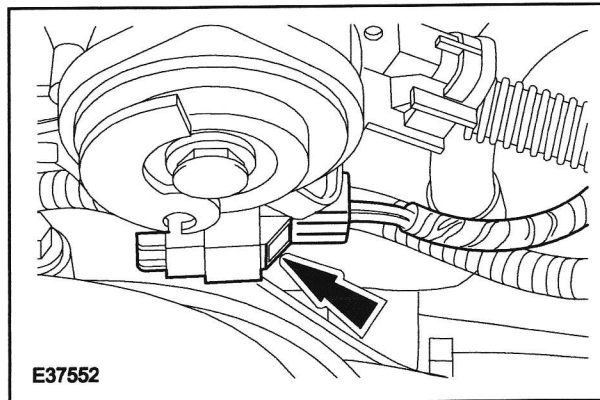

Illustration 34

42. Connect throttle body coolant hose (see Illustration 38).

Note: Uncap the coolant hose.

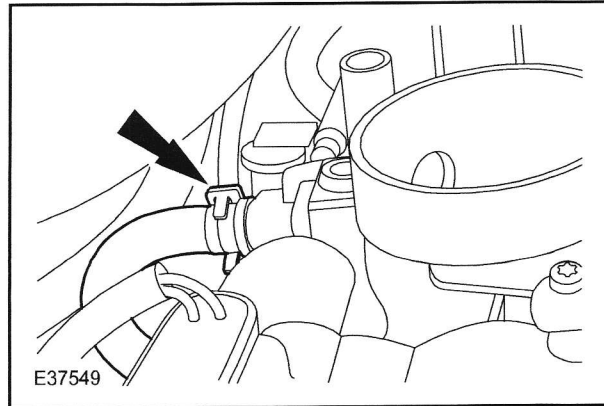

Illustration 38

43. Connect throttle body coolant hose (see Illustration 39).

Note: Uncap the coolant hose.

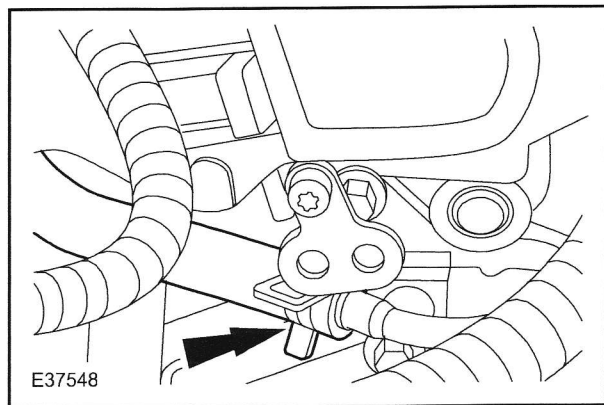

Illustration 39

44. Re-install right-hand camshaft position sensor electrical harness (see Illustration 40).

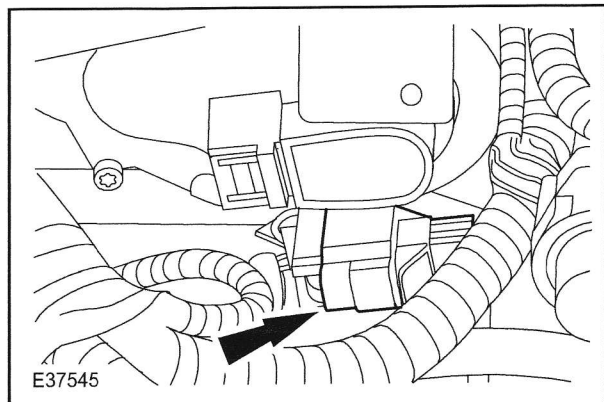

Illustration 40

45. Connect throttle body electrical connectors (see Illustration 41).

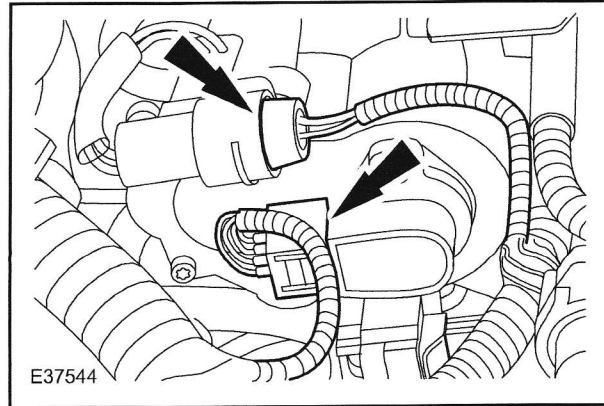

Illustration 41

46. Re-fill cooling system to the correct level.
47. Install cooling system expansion tank pressure cap.
48. Check accelerator cable adjustment.
49. Install air intake/mass air flow sensor/air cleaner cover assembly (see Illustration 42).

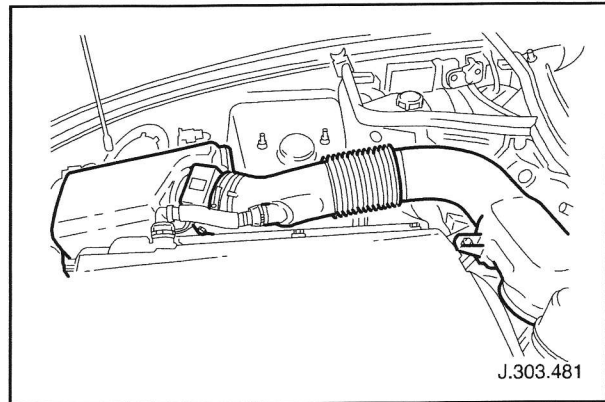

Illustration 42

50. Connect battery.
51. Re-align battery cover and close luggage compartment lid.
52. Remove fender protectors and close hood.

LOCATION OF LABEL UNDER HOOD (V8 XJ SERIES)

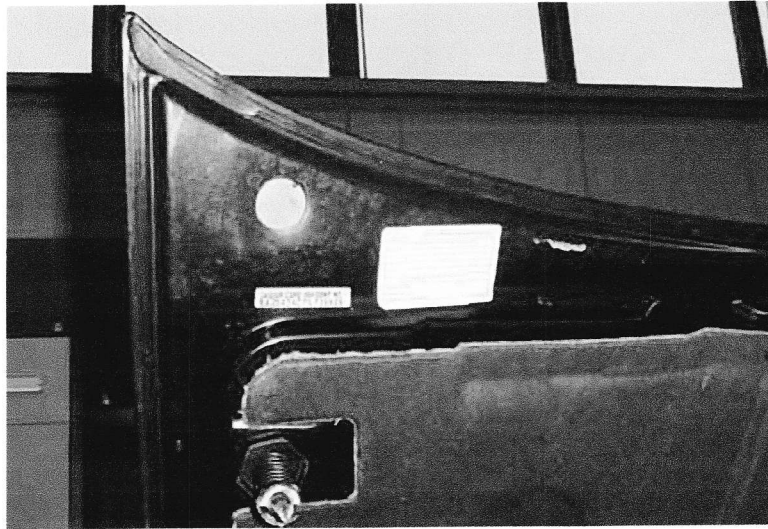

ILLUSTRATION 3

PROOF OF CORRECTION FORM

California Dealers (and any other states where required): Fill out and place the salmon colored "Vehicle Emission Recall - Proof of Correction" form (Illustration 4, part no. S CAL RCL) in the vehicle glove compartment.

PROOF OF CORRECTION FORM

 Vehicle Emission Recall - Proof of Correction							
Vehicle Identification Number							
<table border="1" style="width: 100%; border-collapse: collapse;"> <tr> <td style="width: 25%; height: 15px;"></td> <td style="width: 25%; height: 15px;"></td> <td style="width: 25%; height: 15px;"></td> <td style="width: 25%; height: 15px;"></td> </tr> </table>							
License Number	Make	Year Model	Body Type				
Manufacturer <u>JAGUAR CARS</u>		Recall Number _____					
The above described vehicle has been repaired modified and/or equipped with new emission control devices to meet applicable California Emission Control Laws.							
Dealer's Name		Address, City, State and Zip					
Date	Dealership's Authorized Signature						
	x						

ILLUSTRATION 4

Note: Refer to Administration Bulletin 6-94, for information on obtaining additional Authorized Modification labels or Proof of Correction forms.

Parts Information:

<u>DESCRIPTION</u>	<u>PART NUMBER</u>	<u>QTY</u>
EGR transfer pipe - All	AJ8 6857	1
Gasket - pipe to manifold - All	NCA 4771DA	1
Gasket - pipe to EGR valve - All	AJ8 5476	1
Throttle body gasket - XKR only	NNE 3021AC	1
Cable tie - XKR only	ADU 9028	1

