

Jaguar XK8 ABS 'HARD FAULT' Check Sheet

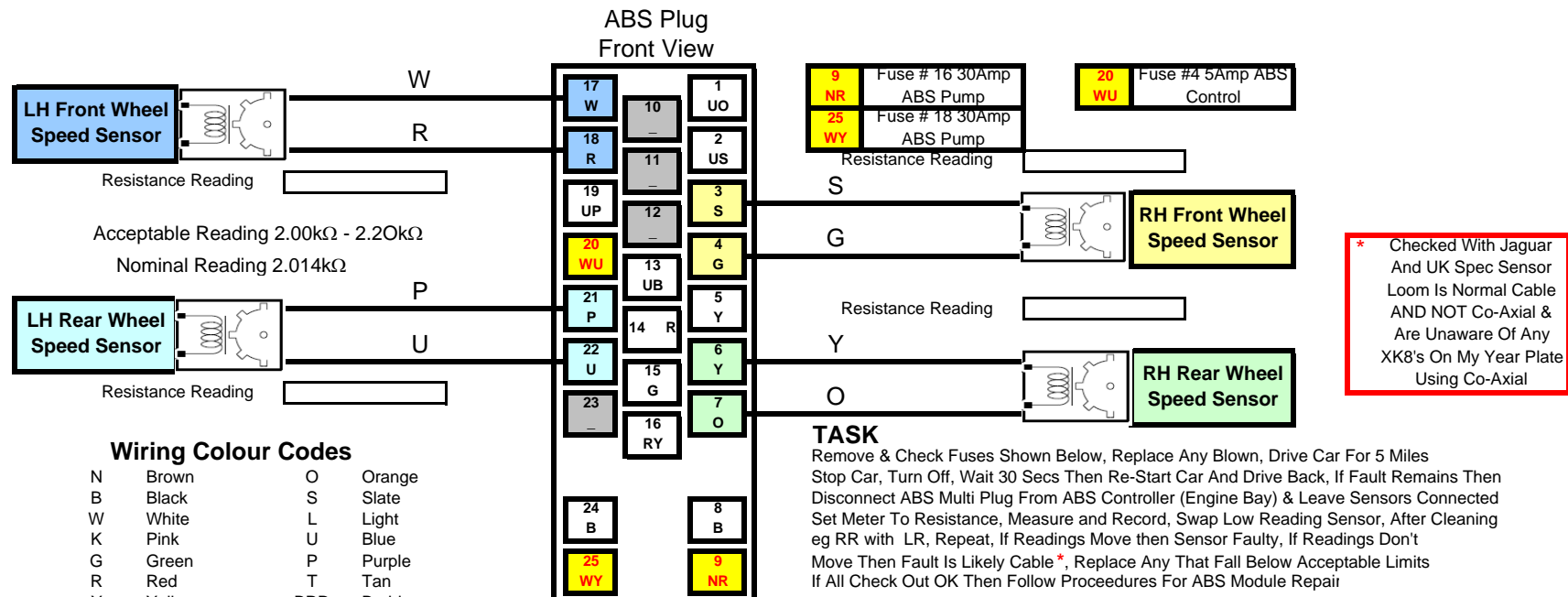

* Checked With Jaguar And UK Spec Sensor Loom Is Normal Cable AND NOT Co-Axial & Are Unaware Of Any XK8's On My Year Plate Using Co-Axial

TASK

Remove & Check Fuses Shown Below, Replace Any Blown, Drive Car For 5 Miles Stop Car, Turn Off, Wait 30 Secs Then Re-Start Car And Drive Back, If Fault Remains Then Disconnect ABS Multi Plug From ABS Controller (Engine Bay) & Leave Sensors Connected Set Meter To Resistance, Measure and Record, Swap Low Reading Sensor, After Cleaning eg RR with LR, Repeat, If Readings Move then Sensor Faulty, If Readings Don't Move Then Fault Is Likely Cable*, Replace Any That Fall Below Acceptable Limits If All Check Out OK Then Follow Procedures For ABS Module Repair

