

Introduction

In the event of a flat tyre, drivers should follow closely the procedure for wheel changing and jacking given in this section. The correct jacking points and how to locate them are shown. It is important that only the correct jacking points are used.

Where vehicles have the 'Temporary Use' spare wheel, drivers should be aware of the limitations of its use.

Temporary-use Spare Wheel

Observe the following warnings before using the wheel.



WARNING:

1. **Please note temporary-use spare wheel warning label. Adhere to instructions on the label. Failure to comply can be dangerous.**
2. **When a temporary-use spare wheel is fitted, drive with caution and replace with the specified wheel and tyre as soon as possible.**
3. **Do not fit more than one temporary-use spare wheel and tyre assembly at one time.**
4. **The temporary-use spare wheel must be inflated to 410 kPa (4,1 bar, 60 lbf/in²).**
5. **Temporary-use spare wheel, maximum speed is 80 km/h (50 mph).**

Note: Maintenance information for the temporary-use spare wheel is the same as given for normal tyres in Section 5.

Spare Wheel and Jacking Equipment

The spare wheel, jacking equipment and wheel chock are stored under the luggage compartment floor panel.

To remove the spare wheel, remove the luggage compartment floor panel and unscrew the retaining screw (see **A** overleaf).

The tray containing the jacking equipment kit can be removed from the luggage compartment by unscrewing the yellow securing bolt (see **B** overleaf).

The kit comprises: the jack; jack ratchet handle with socket extension; wheel nut wrench with telescopic extension; wheel chock; towing eye and a wheel locking nut extractor tube and key socket (where fitted).

Note: Examine the jack occasionally, clean and grease the threads to ensure it is always ready for an emergency.

4-2 Roadside emergency service

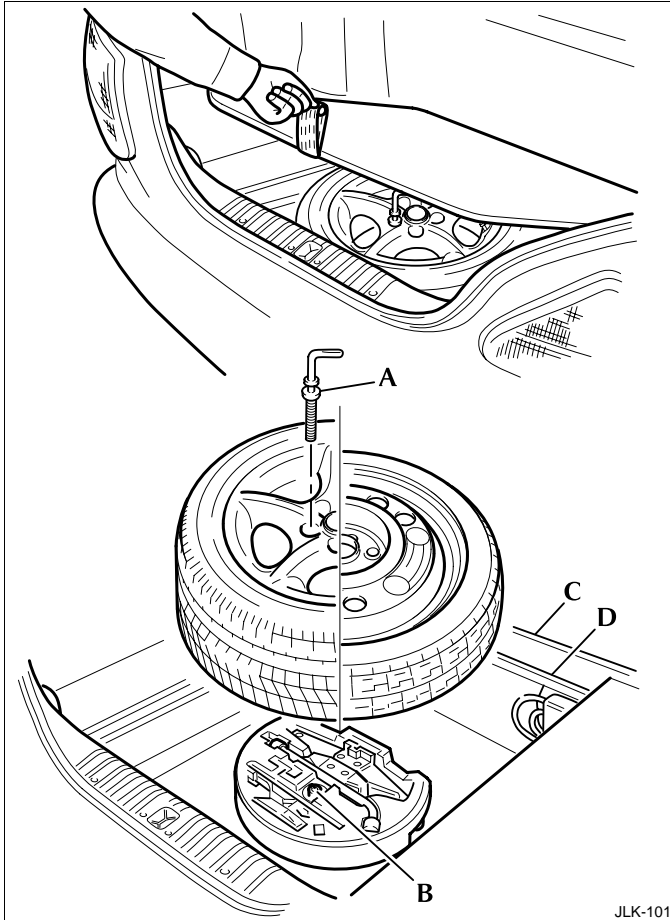

Spare Wheel Stowage

When the temporary-use spare wheel is being used, stow the replaced road wheel in the luggage compartment so that it fits over the jacking equipment tray. Reposition the luggage compartment floor panel in the upper location slots (C).

When the temporary-use spare wheel is returned to the luggage compartment, position the wheel with one stud hole directly over the yellow plastic bolt. Fit the retaining screw through the stud hole into the bolt head and tighten down. Refit the luggage compartment floor panel in the lower position (D).

Note: Remove the centre badge, see illustration on page 4-3.

20 inch diameter road wheels cannot be stored beneath the luggage compartment floor panel. Use the plastic stowage bag and gloves provided in the luggage compartment.



WARNING:

Keep plastic bags away from children.

Wheel Changing and Jacking

Be prepared for a flat tyre. Know where equipment is stowed and read the wheel changing and jacking instructions carefully.

Stopping the Vehicle

Pull off the road completely, clear of all traffic and park on as level ground as possible. Switch on hazard warning lights.



WARNING:

It can be dangerous to change a wheel when the vehicle is on a slope or soft, uneven ground.

Wheel Changing and Jacking (continued)

Remove the temporary-use or full size spare wheel to obtain the jack and wheel changing tools.

Alloy Wheels with Centre Badge

When changing wheels, carefully remove the centre badge and transfer it to the replacement wheel (when a full size spare wheel is used).

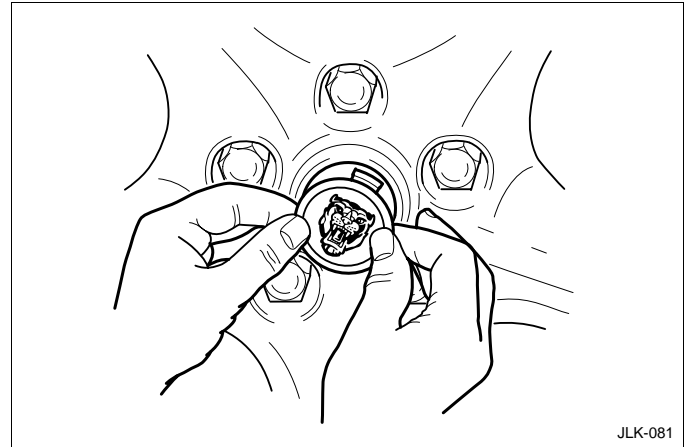

JLK-081

Alloy Wheels with Hexagon Centre Wheel Nut Covers

Remove the cover with the plastic spanner supplied with the spare wheel jacking equipment.

Loosening the Wheel Nuts

Always slightly loosen the wheel nuts before raising the vehicle. A label showing correct use of the wheel nut wrench is printed on its shaft and states:

WHEEL NUT REMOVAL

WHEEL NUT TIGHTEN

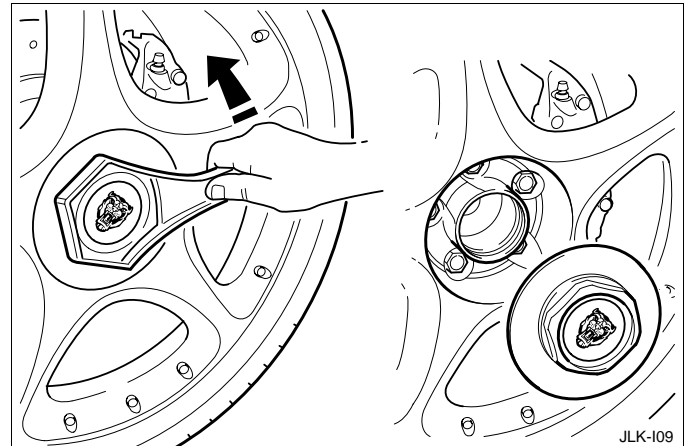

JLK-109



WHEEL NUT REMOVAL

WHEEL NUT TIGHTEN

JLK 053

4-4 Roadside emergency service

Wheel Changing and Jacking (continued)

Removing Locking Wheel Nuts (where fitted)

Some vehicles are fitted with one locking wheel nut on each wheel. These can only be removed using the extractor tube and key socket from the jacking equipment tray.

The locking wheel nut is provided with a cover which makes it visually similar to standard wheel nuts. The top of the cover has an indentation (A) to aid identification.

Push the extractor tube firmly over the locking wheel nut cover, as shown at (B), until it is fully located.

Withdraw the extractor tube to remove the cover.

Fit the key socket over the locking wheel nut as shown at (C).

Fit the wheel nut wrench over the key socket and loosen the locking wheel nut.

Locking Wheel Nut Security Coding

Locking wheel nuts have a letter stamped on their upper surface. The key socket is stamped with a corresponding number. Only key sockets with the correct matching number will fit the locking wheel nut.

Should a new key socket be required, note the letter on the locking wheel nut and contact your Jaguar Dealer. Proof of vehicle ownership will be required.

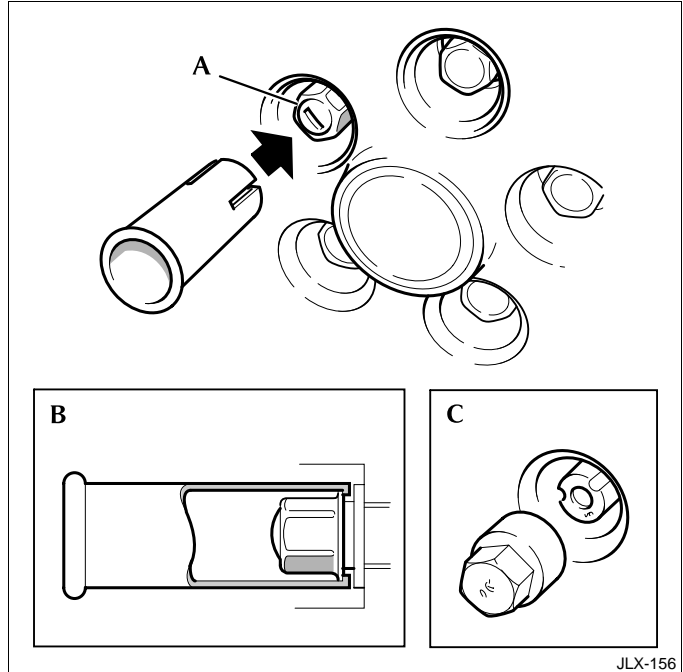

Wheel Changing and Jacking (continued)

Before Lifting the Vehicle



WARNING:

Before attempting to lift the vehicle with the jack, chock one of the front wheels to prevent the vehicle from rolling when jacked up.

A folding wheel chock is supplied with the jacking equipment. The chock must be unfolded into a triangular form before use.

Chock the front wheel on the opposite side of the vehicle to the side being jacked up as shown below:

Note:

1. Ensure that all passengers are in a safe place clear of the vehicle.
2. Ensure that the jack is on firm and level ground.
3. Firmly apply the handbrake and select position 'P' (Park).

Using the wheel nut wrench with the handle extended, slacken, but do not remove the wheel nuts

VEHICLE FACING DOWN A SLOPE

Chock the front of the front wheel

VEHICLE FACING UP A SLOPE

Chock the rear of the front wheel

VEHICLE HORIZONTAL

Front wheel change: Chock at **A**
Rear wheel change: Chock at **B**

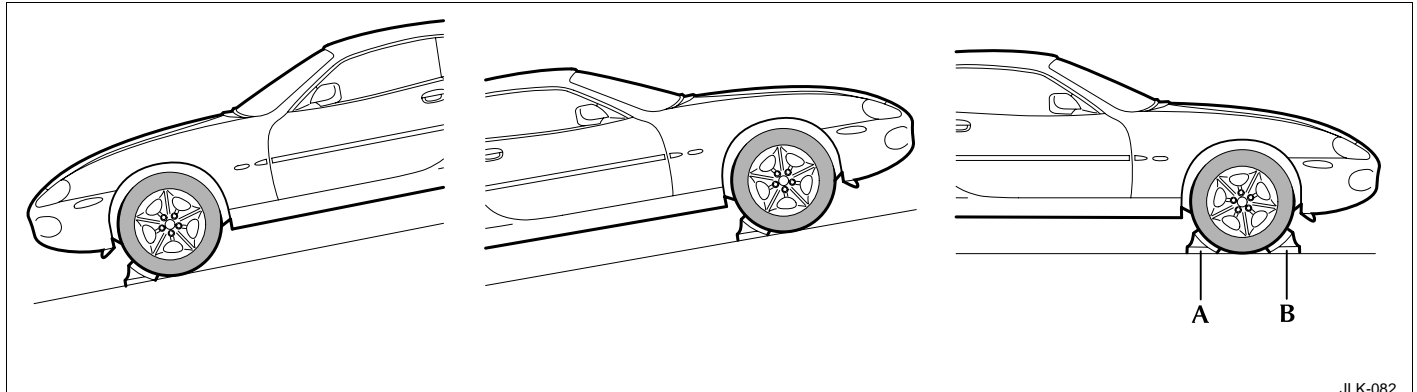

4-6 Roadside emergency service

Wheel Changing and Jacking (continued)

Jacking



WARNING:

Never work under the vehicle using only the jack as a support, always use axle stands or suitable supports under the jacking points.

Observe the instructions printed on the jack.

Use the jack only for lifting the vehicle during wheel changing, and only use the jack which is stored in the vehicle.

Do not start or run the engine while the vehicle is only supported by a jack.

Note: When one rear wheel is lifted off the ground the automatic transmission 'P' (Park) position will not prevent the vehicle from moving and possibly slipping off the jack.

There are four jacking points, two each side. These are reinforced metal plates (A) attached to the sill near each wheel.

Caution: Never use bumpers or any other part of the body to lift the vehicle.



WARNING:

Do not attempt to lift the vehicle unless the sill plate is fully engaged in the jack plate groove.

Place the jack squarely beneath the appropriate jacking point. Fit the extension socket to the jack ratchet head and fit it to the jack. Ensure that the jack plate groove is fully engaged with the sill plate.

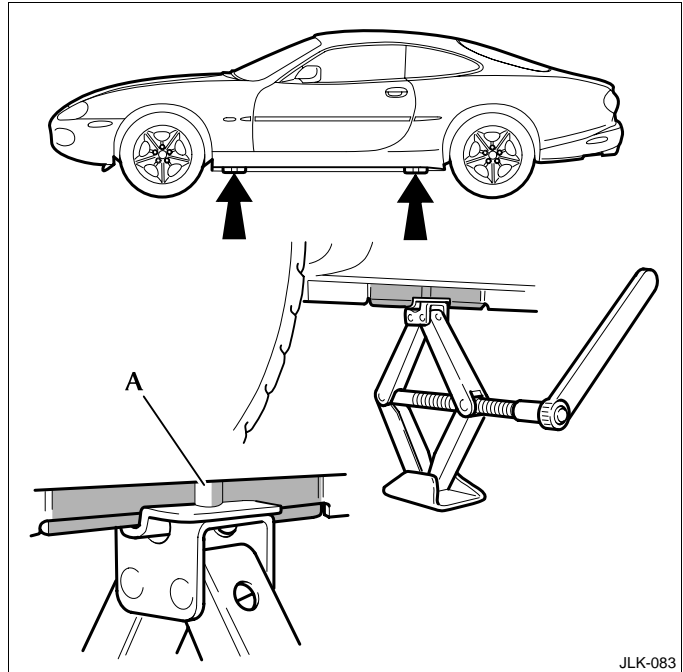

JLK-083

Carefully raise the vehicle by turning the ratchet handle.

Note: Stop jacking the vehicle when the tyre just clears the ground. Minimum tyre lift gives maximum vehicle stability. Remove the wheel nuts and the wheel.

Wheel Changing and Jacking (continued)

Fitting the Spare Wheel



WARNING:

When using the wheel nut wrench, only use the extension for removing wheel nuts, NOT for tightening.

Fit the spare wheel and secure with the wheel nuts.

Use the wheel nut wrench, lightly tighten the wheel nuts alternately using the sequence shown. Ensure that the taper on the wheel nuts is seated fully onto the taper faces of the wheel disc.

Lower the jack and with the wrench handle not extended, tighten the wheel nuts alternately. At the earliest opportunity have the wheel nuts tightened with a torque wrench to 88 – 102 Nm (65 – 75 lbf.ft). Do not exceed this torque.

Remove the jack from the vehicle.



WARNING:

When the temporary-use spare wheel has been fitted, drive with caution and replace with the specified wheel and tyre as soon as possible.

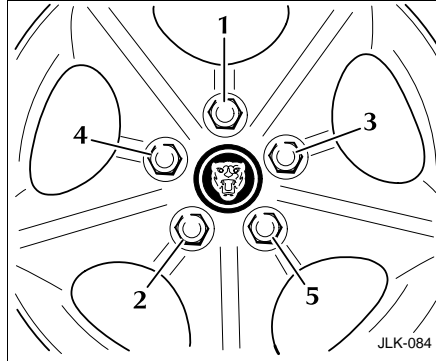

Re-fitting Centre Badge (where fitted)

Press fit the centre badge into position on the wheel.

Refitting Hexagon Centre Wheel Nut Cover (where fitted)

Tighten the hexagon centre wheel nut cover to the wheel with the plastic spanner supplied with the spare wheel jacking equipment.

Stowing the Equipment

Remove the chock and fold flat.

Stow the jack, wheel chock and tools in the jacking equipment tray. If removed, refit the tray in the luggage compartment and secure with the yellow securing bolt.

Place the wheel over the tray and refit the luggage compartment floor panel.

Note: When the temporary-use spare wheel is returned to the luggage compartment, fit and tighten the retaining screw.

4-8 Roadside emergency service

Emergency Starting

Rolling Start

A start by pushing or towing cannot be achieved on a vehicle with automatic transmission.

Emergency Starting Using Jump Leads

Both the booster and discharged battery should be treated with great care when using jump leads. Always use high quality leads capable of carrying the starter current of the vehicle to be started.

Before commencing, the following precautions must be taken:

1. When the battery of another vehicle is being used, ensure that the vehicles do not touch, or remove the charged battery and place near to, not on, the vehicle with the discharged battery.
2. Ensure that both vehicles have all electrical services OFF, the handbrake is ON and the transmission is in Park.
3. Where the jump leads are of a different colour, e.g. red and black, use red for positive (+). This aids identification and helps to avoid crossing positive (+) to negative (-). Take extra care to avoid crossing the polarity when using cables of the same colour.

Caution:

1. **If using a jump start vehicle, under no circumstances should the vehicles come into contact with each other. This could establish an earth connection, which may cause sparks and damage.**
2. **Do not run the jump start vehicle's engine when boost starting a Jaguar Vehicle. If the jump start vehicle's engine is running and the jump leads are disconnected, damage to the Jaguar vehicle's electrical system will result.**
3. **The booster battery voltage must not exceed 12 volts.**

The following procedure must be followed exactly, being careful not to cause sparks.

1. Apply the handbrake, select Park and turn off all the vehicle's electrical services.
2. Remove the luggage compartment floor panels.
3. Unclip the positive (+) terminal cover.
4. Attach one end of the red jump lead to the positive (+) terminal of the **booster** battery and the other end to the positive terminal of the discharged battery. **Make sure that a good connection is made. Do not allow the vehicles to touch.**

Continued

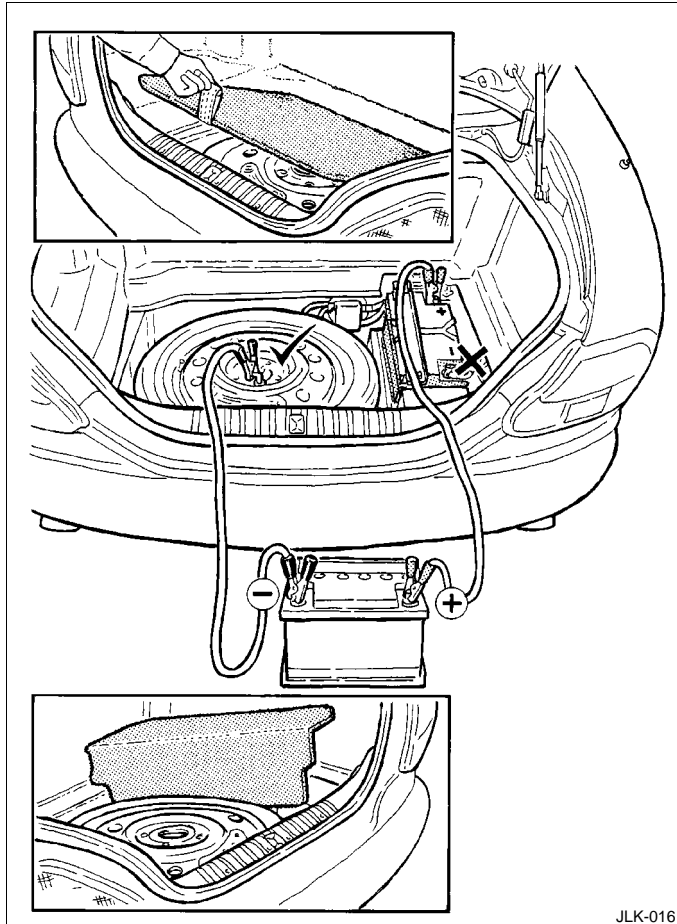

Caution: Do not connect the negative jump lead directly to the negative (-) terminal of the discharged vehicle.

5. Attach one end of the black jump lead to the negative (-) terminal of the **booster** battery and the other end to an earth point on the vehicle being started. (Use the spare wheel retaining bolt as shown.) The earth point must be at least 305 mm (12 inches) from the discharged battery. Make sure that a good connection is made.
6. When started allow the engine to idle for five minutes before disconnecting the cables.
7. Disconnect the black jump lead from the earthpoint and the booster battery negative (-) terminal. Disconnect the red jump lead from the positive (+) terminals of both batteries.

Note: Disconnection is done in the reverse order to the connecting procedure.

8. Refit the positive terminal cover and the floor panels.
9. Refit the luggage compartment floor panels.

4-10 Roadside emergency service

Vehicle Recovery

The preferred vehicle recovery method is by using a flat bed transporter or rear suspended tow. The front and rear towing eyes are primarily for emergency use when towing for SHORT DISTANCES, e.g. removing the vehicle if it is causing an obstruction or for winching the vehicle onto a recovery transporter.

Transporting

If the vehicle is being transported on a trailer or vehicle flat bed transporter, the handbrake must be applied, the wheels chocked and the gear selector lever moved to position 'N' or 'D' but NEVER to 'P'.

The vehicle must be securely tied down to the transporter or trailer. Do not attach tie-down hooks to the towing eyes.

Suspended Towing

Ensure that the recovery team follow these instructions:

Do not tow with sling-type equipment since damage to the bodywork may result.

Caution: Do not tow vehicle by suspending the front end.

1. Remove the key from the ignition switch.
2. Raise the rear of the vehicle using a 'spectacle frame' type lifting device where a cradle is positioned under each rear wheel, as indicated.

Vehicles with Defective Automatic Transmission

The vehicle must be towed with the rear wheels clear of the ground.

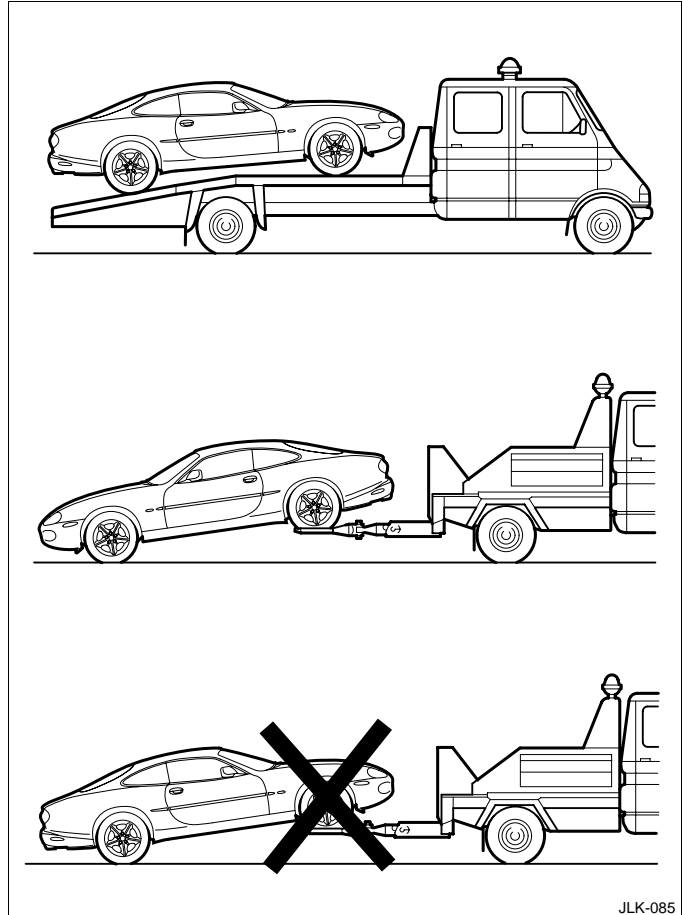

Towing Eyes



WARNING:

The vehicle must not be driven with a towing eye fitted to a front tow point.

Caution: The towing eyes are not suitable for 'solid bar towing'.

Care must be taken to avoid damaging the bumpers and front apron.

The front towing eye is detachable. When not in use it is stowed in the jacking equipment kit (see page 4-1). To use, remove the rubber blanking plug from the front cross-member, on the driver's side and screw the eye into the threaded drilling. The blanking plugs are a push-fit in the towing eye threads.

The rear eye is welded to the right-hand side of the luggage compartment underfloor panel.

Always obey towing regulations: In certain countries the registration number of the towing vehicle and an 'ON TOW' sign or warning triangle must be displayed in a prominent position at the rear of the vehicle being towed.

When being towed, the vehicle's gear selector lever must be in neutral (position 'N') with the ignition key turned to position 'II' to release the steering lock and render the indicators, horn and brake lights operational.

Vehicles may be towed for SHORT DISTANCES (maximum 0.8 kilometres/0.5 miles) with the gear selector lever in position 'N', provided a speed of 48 km/h (30 mph) is not exceeded.

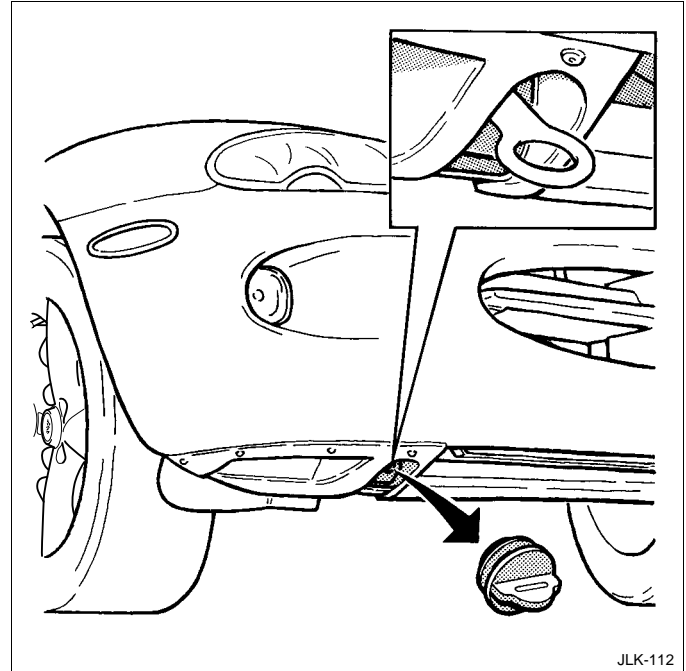

WARNING:

When the engine is not running the steering and brakes will no longer be power-assisted. Therefore, be prepared for relatively heavy steering and the need for greatly increased brake pedal pressure.

4-12 Roadside emergency service

Fuses and Fuse Boxes

Fuse failure is signalled by an inoperative circuit.

Do not fit a new fuse if damage to the wiring is found; contact a Jaguar Dealer. After renewing a fuse have the circuit checked by a Jaguar Dealer.

Spare fuses and a special tool for removing the fuses are supplied underneath the electrical carrier lid in the luggage compartment.

Use only the spare fuses supplied. Replace the spare with a Jaguar approved fuse of the same amperage rating.

Checking and Renewing a Blown Fuse

Make sure the new fuse is the correct rating (amperage). Fuses are colour coded according to the amperage and the rating is also marked on each fuse. The colour code is as follows:

TAN	5 amp	CLEAR	25 amp
RED	10 amp	LIGHT GREEN	30 amp
LIGHT BLUE	15 amp	BRIGHT ORANGE	40 amp
YELLOW	20 amp		

Push the tool on to the suspect fuse and withdraw it.

If the wire in the fuse is broken, the fuse has blown.

A – Fuse in good condition. **B** – Blown fuse.

Fit a new fuse using the tool.

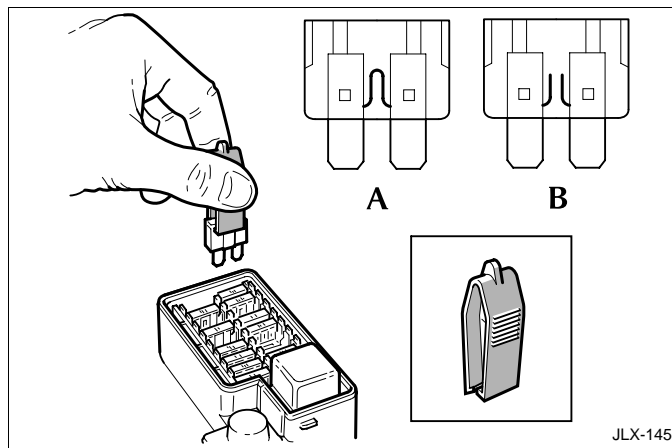
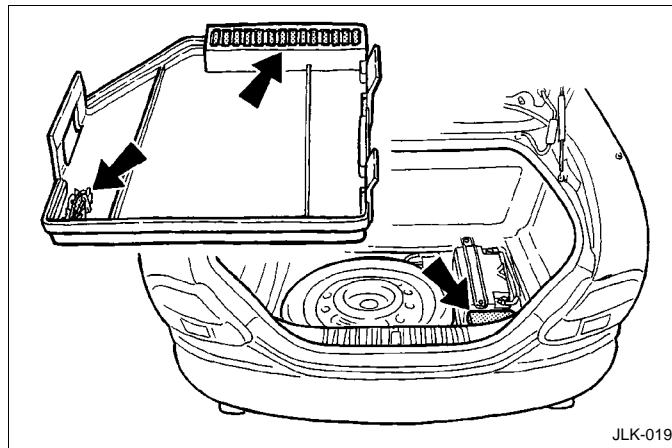

Fuse Box Locations

There are five separate fuse boxes fitted to the vehicle, each one containing fuses protecting a different group of circuits.

Some fuse box locations change with left-hand drive and right-hand drive vehicles. In these cases the terms 'driver's side' and 'passenger's side' have been used.

There are two types of fuse box:

type A – 18 way with one relay.

type B – 22 way with seven relays.

The locations are as follows:

Type A Fuse Boxes

B Engine compartment fuse box (right-hand drive vehicles) – Passenger's side, within bulkhead extension.

or

C Engine compartment fuse box (left-hand drive vehicles) – Passenger's side, within bulkhead extension.

D Fascia fuse box – Driver's side, on the end of the fascia behind the removable panel.

E Fascia fuse box – Passenger's side, on the end of the fascia behind the removable panel.

Note: Left-hand drive vehicle shown

Type B Fuse Boxes

A Engine compartment fuse box – Left-hand side, behind the windscreen washer reservoir.

F Electrical carrier fuse box – Luggage compartment.



WARNING:

1. Do not fit a fuse of a different amperage from that specified on the Master Label. The electrical circuits may become overloaded with the subsequent possibility of a fire.
2. No attempt should be made to repair a fuse that has blown. This may cause a fire hazard or serious damage elsewhere in the electrical circuit.

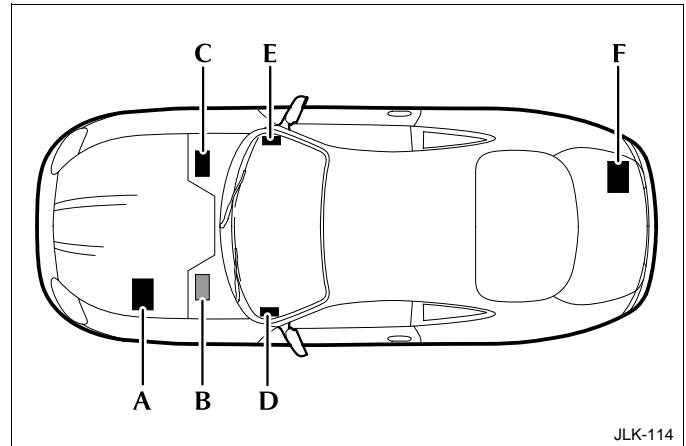

4-14 Roadside emergency service

Engine Compartment Fuse Boxes

There is one fuse box in the main engine compartment, located on the left-hand side, behind the windscreen washer reservoir.

Caution: When the fuse box lid is removed, take care to protect the box from moisture, and refit the lid at the earliest opportunity.

Remove the fuse box lid by pressing the retaining lugs and lifting.

When refitting, press the fuse box lid in the area of the retaining lugs until the lid engages.

The circuits protected are listed on page 4-19.



A second fuse box is situated within the bulkhead extension on the passenger's side.

Note: The bulkhead extension protects electrical components from the heat generated in the engine compartment.

Remove the fuse box lid by compressing and lifting the 'U' shaped latching mechanism (A).

To refit the fuse box lid, position into the slots and push down until the latching mechanism is engaged.

The circuits protected are listed on page 4-16.

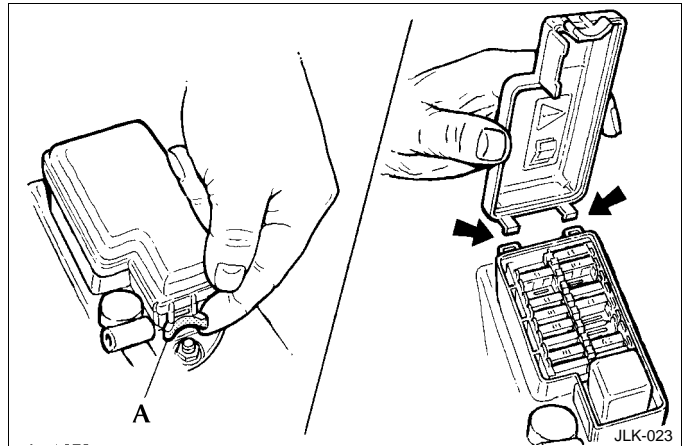

Fascia Fuse Boxes

Fuse boxes are located at the extreme ends of the fascia, one on the driver's side and one on the passenger's side.

Pull the raised lip of the cover to access the fuse box.

The circuits protected are listed on page 4-17 and 4-18.

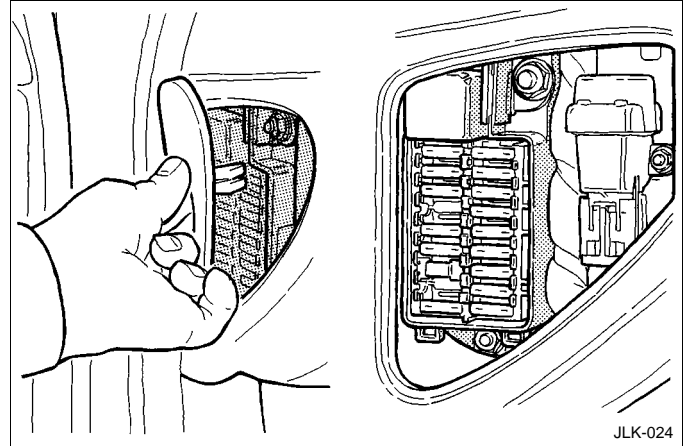

Luggage Compartment Fuse Box

A fuse box is located in the electrical carrier which is situated to the rear of the battery.

A list of protected circuits and fuse ratings is given on the fuse allocation chart (Master Label) which is attached to the lid of the electrical carrier.

Caution: When the carrier lid is removed, take care to protect the box from moisture ingress, and refit the lid at the earliest opportunity.

Remove the luggage compartment floor panel.

Remove the electrical carrier lid by pulling the retaining clips and pulling the lid upwards.

Spare fuses and a special tool for removing the fuses are supplied underneath the electrical carrier lid in the luggage compartment.

Reposition the lid and press down until the retaining clips engage.

The circuits protected are listed on page 4-20.

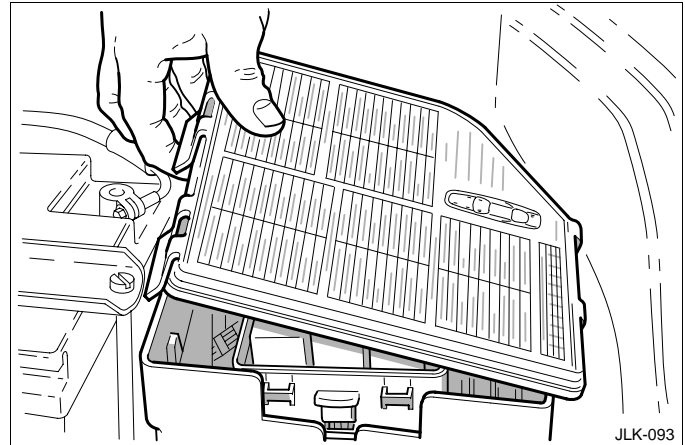

4-16 Roadside emergency service

Fuse Ratings and Circuits

Engine Compartment Fuse Box Passenger Side – Within Bulkhead Extension

Fuse No	Ratings (amps)	Circuit
1	30	HO2 sensor heaters.
2	20	Intercooler water pump (Supercharged).
3	25	Starter solenoid.
4	5	Engine control module, transmission control module.
5	10	Injector supply.
6	–	Not used.
7	–	Not used.
8	10	Air conditioning compressor clutch.
9	30	Throttle motor.
10	5	Engine control module, Park/Neutral switch, cruise control VSV 1 and 2 (where fitted).

Fuse No	Ratings (amps)	Circuit
11	10	Adaptive cruise control smartbooster & relay.
12	10	Air flowmeter, VVT solenoids, radiator fans control module.
13	–	Not used.
14	10	HO2 sensor heaters relay (where fitted), EGR valve (where fitted), EVAP valve, ignition coils relay, throttle motor relay, AC compressor clutch relay.
15	30	Windscreen left-hand heater.
16	5	Engine control module cooling fan.
17	30	Windscreen right-hand heater.
18	10	Ignition coils supply.

B or C on location illustration, page 4-13.

Fascia Fuse Box – Driver's Side

Fuse No	Ratings (amps)	Circuit
1	20	Driver's seat control module.
2	10	Door mirror heaters.
3	30	Windscreen wiper motor relays.
4	10	Airbag.
5	15	Body processor module (5 V logic and lamps).
6	5	Centre console switches, key transponder module, convertible top header console, rain sensing.
7	15	Body processor module (battery supply for solenoids, lamps and motors).
8	5	Steering column adjust switch, driver's seat switchpack, driver's seat belt buckle switch
9	–	Not used.
10	5	Diagnostic connector (ignition).
11	20	Air conditioning driver's blower motor.

Fuse No	Ratings (amps)	Circuit
12	10	Door mirror heaters relay, Air conditioning: compressor lock, control module ignition supply, blower motor relays, power steering control module.
13	5	Diagnostic connector (battery).
14	10	Cruise control ON/OFF switch, main instrument cluster, catalytic converter over temperature warning control module.
15	25	Driver's door control module, transit relay.
16	5	Electrochromic interior mirror (where fitted), windscreen heater relay, gear selector, transmission mode switch, linear switch.
17	10	Accessory sockets.
18	5	Main instrument cluster (includes clock).

D on location illustration, page 4-13.

4-18 Roadside emergency service

Fascia Fuse Box – Passenger's Side

Fuse No	Ratings (amps)	Circuit
1	20	Passenger seat control module.
2	10	Door locking actuators.
3	–	Not used.
4	5	Door switchpacks, door locking.
5	5	Telephone transceiver and RT connector.
6	10	Air conditioning control module.
7	20	Body processor module (column motor power).
8	5	Passenger seat switchpack, passenger seat belt buckle switch.
9	10	Radio/cassette head unit.
10	5	Telephone handset and transceiver.

Fuse No	Ratings (amps)	Circuit
11	20	Air conditioning passenger's blower relay.
12	5	Radio/cassette unit.
13	–	Not used.
14	20	Cigar lighter.
15	25	Passenger door control module, transit relay connector.
16	5	Navigation.
17	15	Body processor module (light, high power sockets).
18	10	Dimmer control module.

E on location illustration, page 4-13.

Engine Compartment Fuse Box – Left-hand Side

Fuse No	Ratings (amps)	Circuit
1	10	Transmission control module.
2	5	Alternator regulator.
3	5	Security sounder, headlamp levelling motors, headlamp levelling switch, ignition +Ve, centre console switchpack, adaptive cruise control.
4	5	ABS control module.
5	10	Starter relay, engine control module.
6	10	Right-hand dipped beam headlamp.
7	30	Power wash pump.
8	10	Left-hand dipped beam headlamp.
9	10	Security sounder.
10	–	Not used.
11	10	Right-hand horn.

Fuse No	Ratings (amps)	Circuit
12	30	Cooling fans series/parallel.
13	10	Left-hand horn.
14	30	Cooling fans parallel.
15	10	Air conditioning coolant pump.
16	30	ABS control valves.
17	15	Front fog lamps.
18	30	ABS pump motor.
19	10	Right-hand main beam headlamp.
20	–	Not used.
21	10	Left-hand main beam headlamp.
22	5	Adaptive cruise control module.

A on location illustration, page 4-13.

4-20 Roadside emergency service

Luggage Compartment Fuse Box – Electrical Carrier

Fuse No	Ratings (amps)	Circuit
1	5	Coupe: Reversing lamps. Convertible: Reversing lamps, rear quarter windows raise/lower relays.
2	20	Adaptive damping control module.
3	5	Fuse box ignition +Ve, bulb monitoring control module, S/C fuel pump relay.
4	5	Adaptive damping control module.
5	5	Airbag.
6	5	Right and left-hand stop lamps via bulb monitoring control module.
7	20	Fuel pump.
8	5	High mounted stop lamp.
9	10	Antenna motor.
10	10	Security and locking control module.
11	10	Accessory sockets
12	– 20	Coupe: Not used. Convertible: Right-hand rear quarter window lift motor

Fuse No	Ratings (amps)	Circuit
13	–	Not used.
14	– 40	Coupe: Not used. Convertible: Raise and lower pump for convertible top.
15	10	Fog lamps.
16	5	Navigation.
17	25	Heated rear screen.
18	30	Power amplifier.
19	5	Right-hand tail, left-hand and right-hand number plate lights.
20	– 20	Coupe: Not used. Convertible: Left-hand rear quarter window lift motor
21	5	Left-hand tail, left-hand and right-hand side marker lights.
22	20	S/C fuel pump.

F on location illustration, page 4-13.

Control Modules – Identification and Location

Control Module	Location
Adaptive Damping	Luggage compartment, rear, right of the spare wheel well.
Airbag (Supplementary Restraint System)	Fascia right-hand side. Behind the glove compartment liner or the driver's knee bolster.
Anti-lock Braking System and Traction Control	Engine compartment, driver's side. Mounted below the ABS hydraulic control unit.
Body Processor	Fascia, mounted on passenger airbag bracket.
Climate Control	Fascia, right-hand side of the climate control unit.
Dimmer	Fuse box on the right-hand end of the fascia.

Control Module	Location
Driver's Door	Driver's door, forward of the glass guide above the speaker.
Driver's Seat	Driver's seat cushion frame.
Engine Management	Engine compartment, passenger side, within bulkhead extension.
Passenger's Door	Passenger's door, forward of the glass guide above the speaker.
Passenger's Seat	Passenger's seat cushion frame.
Security and Locking	Luggage compartment electrical carrier to the rear of the battery.
Transmission	Engine compartment, passenger side, within bulkhead extension.

Relay Identification and Location (continued)

Location	Functions	Case Colour
Luggage compartment to the rear of the battery, under the electrical carrier lid. Note: Micro relays operate rear quarter window functions.	Right to left: Rear quarter windows up (nearest) and down, right-hand side. S/C secondary fuel pump. Rear quarter windows up (nearest) and down, left-hand side. Convertible top lower. Convertible top raise. Spare.	2 x Black Brown 2 x Black Black Black –
Driver's side fuse box at the end of the fascia.	Ignition.	Brown
Passenger's side fuse box at the end of the fascia.	Auxiliary.	Brown
Engine compartment passenger side fuse box, within bulkhead extension.	Engine management system control.	Brown
Engine compartment right-hand side, within bulkhead extension.	From front of vehicle to rear: Starter. Left-hand front screen heater (If fitted). Right-hand front screen heater (If fitted). Intercooler water pump HO2 sensor heaters relay	Brown Brown Brown Brown Brown

4-24 Roadside emergency service

Relay Identification and Location (continued)

Location	Functions	Case Colour
Engine compartment passenger side, within bulkhead extension.	Looking forward from right to left: Ignition coil. Throttle motor power. PI main (injectors).	Brown Brown Brown
Engine compartment left-hand side within bulkhead extension.	From front of vehicle to rear: Air conditioning clutch. Wiper on/off. Wiper fast/slow.	Brown Black Black
Behind the fascia on the left-hand side as viewed from the rear of the car.	Door mirror heater: micro-relay.	Black
Behind the fascia on the right-hand side as viewed from the rear of the car.	From front of vehicle to rear: Door lock: micro-relay. Air conditioning isolate: micro-relay.	Black Black
Footwell, mounted on the left-hand side of the transmission tunnel.	From front of vehicle to rear: Left-hand blower: micro-relay. Right-hand blower: micro-relay.	Black Black
Engine compartment left-hand side, below the headlamp.	Cooling fans: large relay.	Black