

Convertible Soft Top – Manual Closing Procedure

MODEL 1997 MY-ON
XK8 Range
VIN
001001-ON

Remove and destroy Bulletin 501-01, dated 11/96.
Replace with this Bulletin.
Revisions are marked with a bar and in **bold text**.

Issue:

This bulletin details the proper procedure for raising the convertible soft top manually in case the power operation does not work. Damage to the mechanism will occur if the procedure detailed below is not followed.

While the XK8 Technical Guide provides a procedure on page 17 for the technician for lowering the soft top manually, owner’s literature includes the following statement:

CAUTION! Do **not** attempt to lower the soft top manually if it will not operate using the switch, as damage to the linkage can occur.

Action:

In case of a malfunction of the power operating mechanism only, raise the top as follows:

1. Remove the right side trim panel in the trunk to gain access to the soft top hydraulic pump (Illustration 1).
2. Turn the manual valve on the side of the pump fully counterclockwise.
3. Remove the 8mm Allen wrench from its location (Illustration 1).

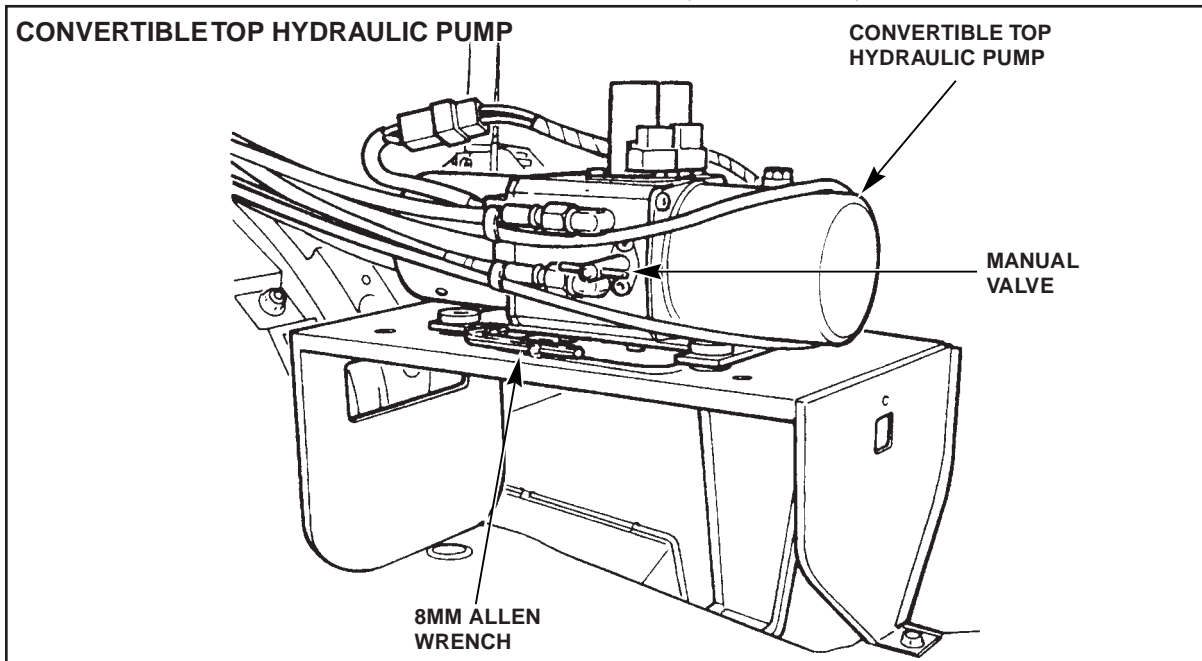

ILLUSTRATION 1

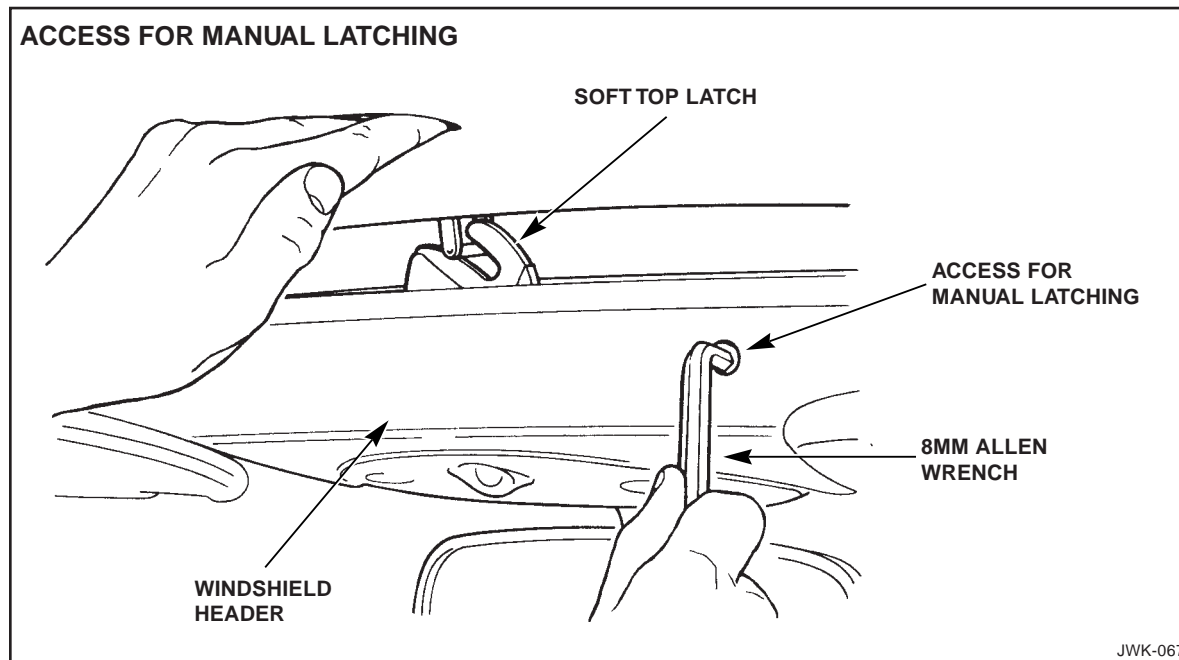

ILLUSTRATION 2

4. Remove the access plug from the windshield header trim cover and insert the Allen wrench (Illustration 2).
5. Turn the Allen wrench until the latch is raised as shown in Illustration 2.
6. Hold the soft top by its front edge. Raise and pull the top forward until the hook can be engaged in the latch.
7. Turn the Allen wrench until the soft top is fully clamped to the windshield header.
8. Remove the Allen wrench and replace the access plug in the windshield header trim cover.
9. Return the Allen wrench to its storage area alongside the pump in the trunk.
10. Rotate the manual valve of the pump completely clockwise.
11. Reinstall the right side trim panel in the trunk.