



S-TYPE

DATE 08/04

S307-16

**SERVICE****TECHNICAL BULLETIN****Selector Lever Difficult To Disengage From Park – Revised Internal Control Lever – Repair Procedure**MODEL 2000-02 MY  
S-TYPE

VIN L00001-M44997

**Issue:**

Some 2000-02 MY S-TYPE vehicles may exhibit difficulties in disengaging the gearshift lever from Park, particularly when the vehicle is parked on an incline. This is caused by the profile of the transmission manual control lever being too severe. A new transmission manual control lever has been released to address this concern.

**Action:**

In case of a verified complaint of the above condition on a 2000-02 MY S-TYPE, follow the workshop procedure outlined below.

WORKSHOP PROCEDURE

1. Open driver door.
2. Switch ignition 'ON'.
3. Apply footbrake, move transmission selector lever to the neutral position and release the footbrake.
4. Switch ignition 'OFF'.
5. Close driver door.
6. Disconnect battery (see Workshop Manual, section: 414-01).
7. Place a suitable drain pan under the transmission.
8. Remove the transmission drain plug and discard the seal.
9. Allow the transmission fluid to drain.
10. Install a new fiber washer and install and tighten the drain plug.
11. Remove transmission extension housing seal (see Workshop Manual, section: 307-01, SRO 44.20.18).
12. Align transmission jack under transmission.
13. Place suitable supporting blocks onto the transmission jack and raise to support the transmission.

**NOTE: The information in Technical Bulletins is intended for use by trained, professional technicians with the knowledge, tools, and equipment to do the job properly and safely. It informs these technicians of conditions that may occur on some vehicles, or provides information that could assist in proper vehicle service. The procedures should not be performed by "do-it-yourselfers." Do not assume that a condition described affects your car. Contact a Jaguar retailer to determine whether the Bulletin applies to your vehicle.**

14. Remove the bolts securing the rear transmission mount.

**⚠ Caution:** Do NOT allow the engine to contact the bulkhead.

15. Lower the transmission jack.

16. Remove extension housing securing bolts, and remove extension housing.  
Remove and discard gasket.

Working with an assistant:

17. Raise rear of the transmission by hand and reposition the jack to support the transmission between the sump and rear of transmission main case (Illustration 1).

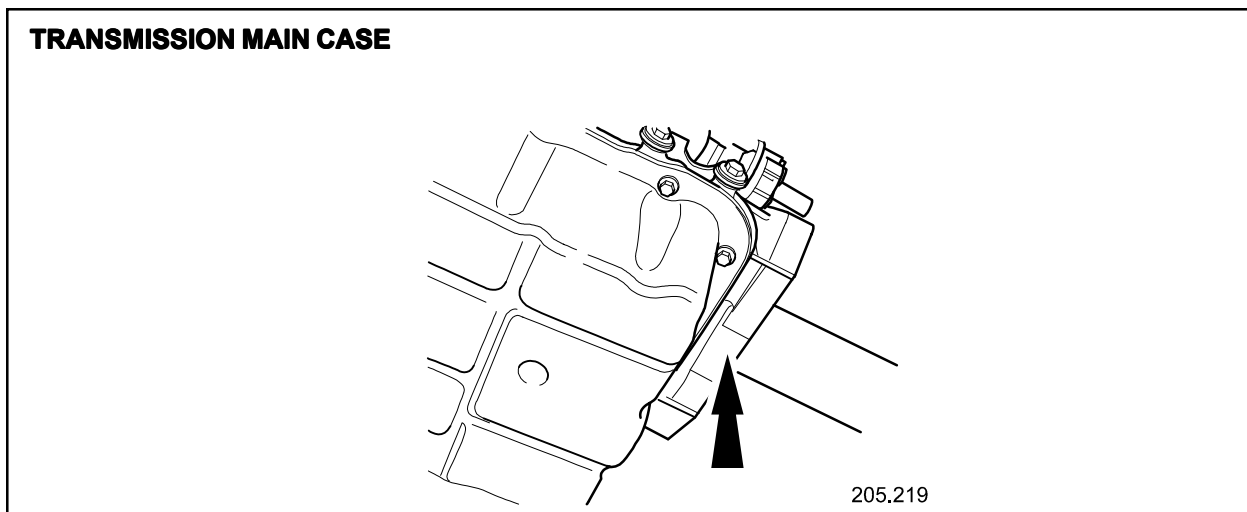

ILLUSTRATION 1

Working alone:

18. Disconnect the transmission range (TR) sensor electrical connector.

19. Remove the securing screws and remove the TR sensor from the transmission (Illustration 2).

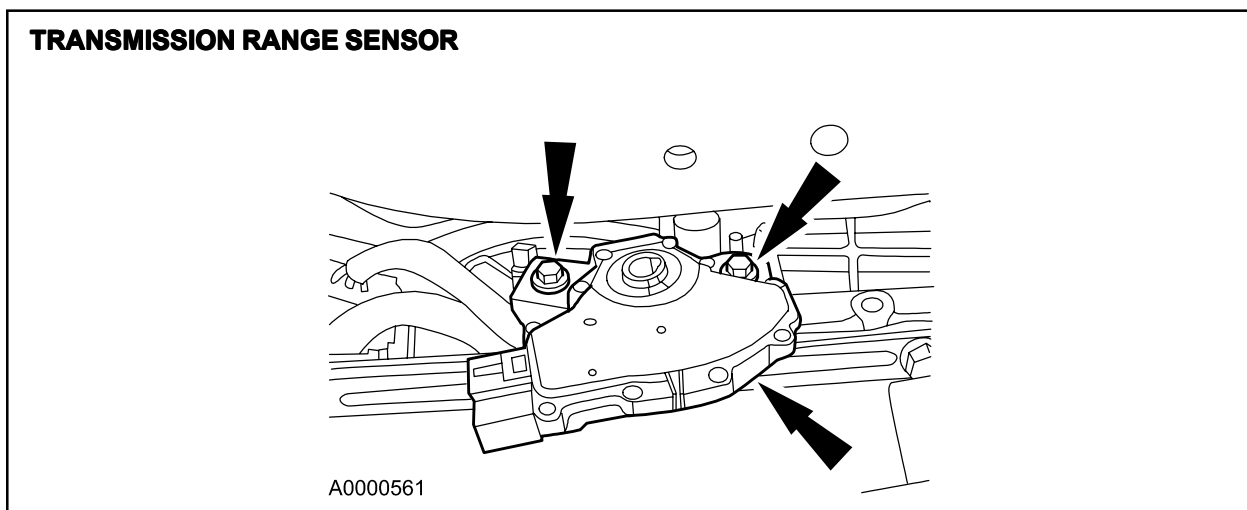

ILLUSTRATION 2

20. Remove transmission fluid pan, gasket and filter (see Workshop Manual, section: 307-01, SRO 44.24.07).
21. Disconnect the solenoid block electrical connector (Illustration 3).

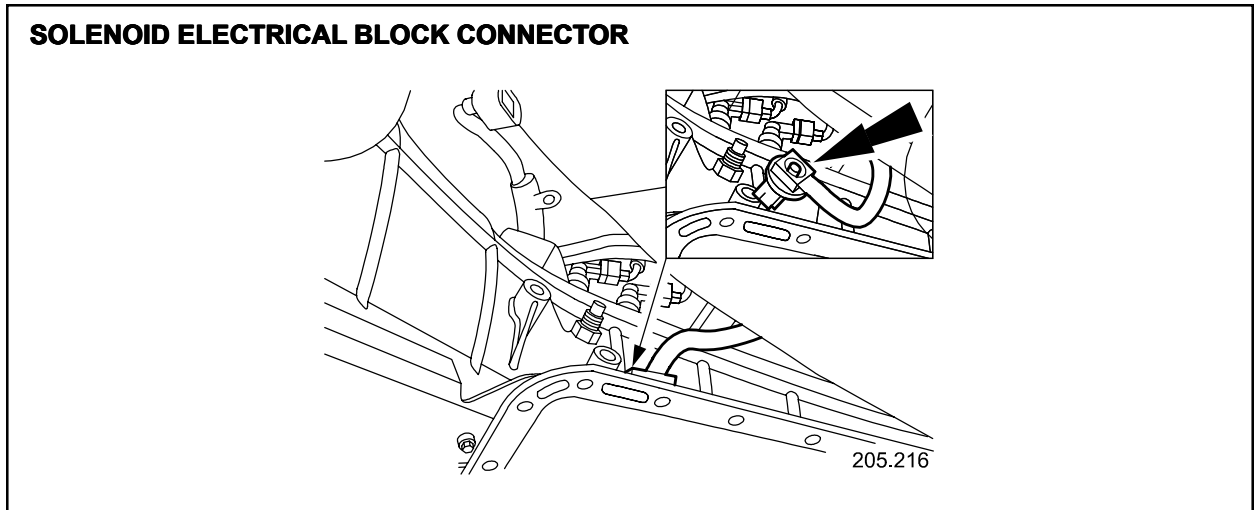

ILLUSTRATION 3

22. Disconnect the pressure switch electrical connector (Illustration 4).

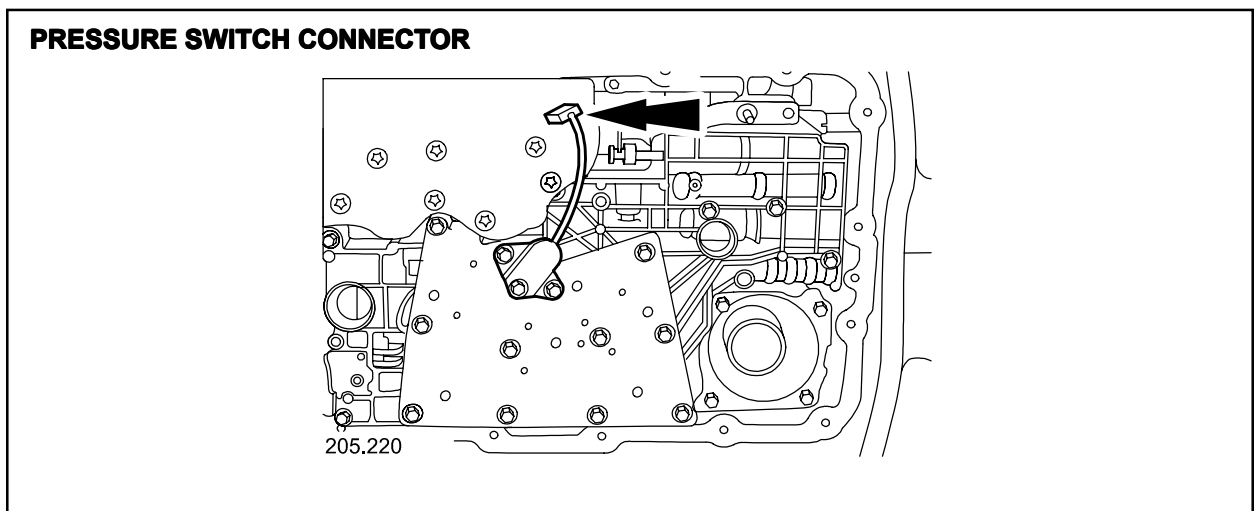

ILLUSTRATION 4

23. Remove the fixing bolts (Illustration 5) and remove the solenoid block. Remove and discard the O-ring.

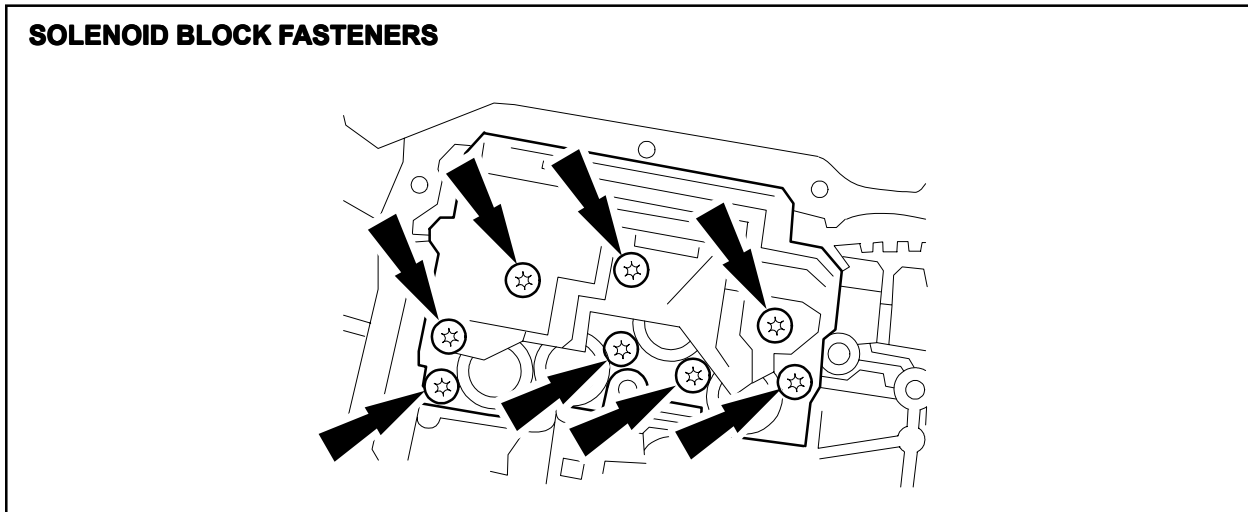

ILLUSTRATION 5

24. Remove the manual control lever detent spring securing bolt (Illustration 6).

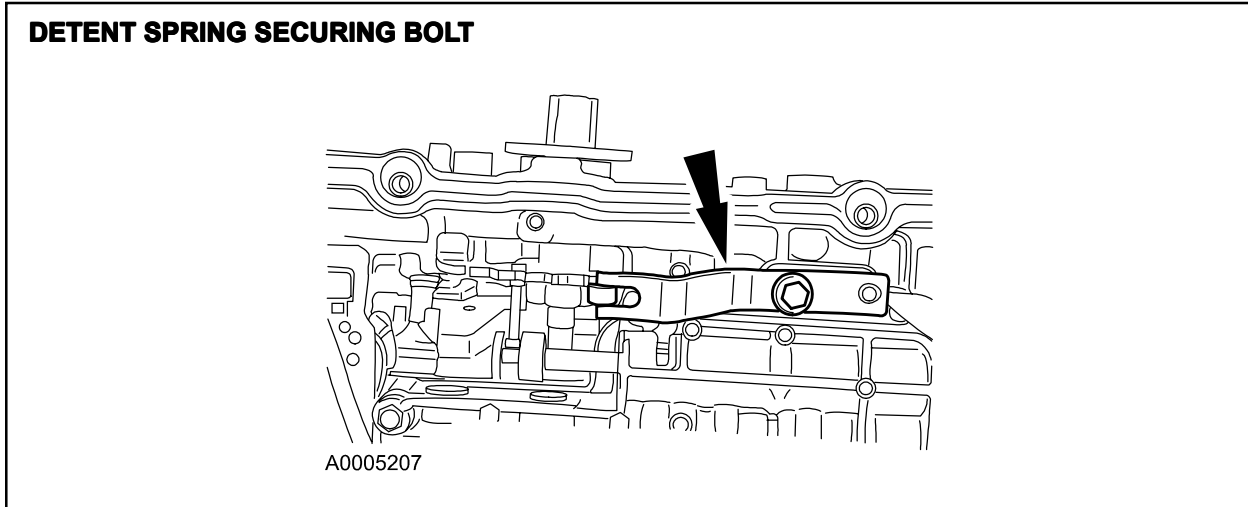

ILLUSTRATION 6

25. Remove the manual control lever detent spring.
26. Disconnect the inner selector cable from the transmission lever ball pin.

**Note:** When rotating the manual shaft to allow removal of its nut, the external lever may foul the inner selector cable and prevent rotation. To overcome the foul condition, the end of the inner cable should be pushed out of the way as required.

27. Remove the manual control lever shaft retaining pin (Illustration 7).

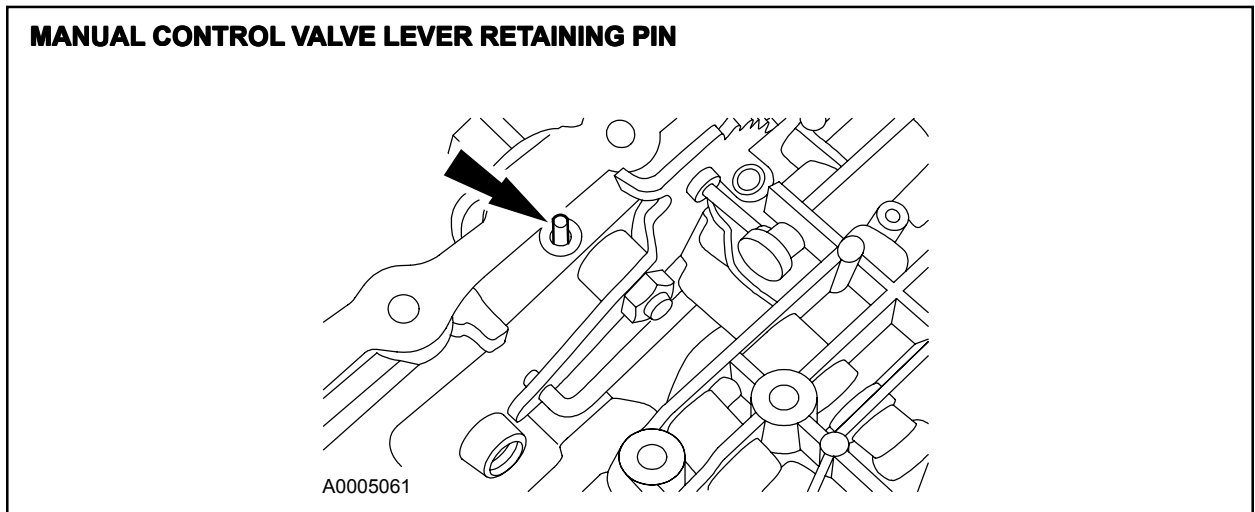

ILLUSTRATION 7

28. Displace the manual control lever shaft from the main case towards the transmission tunnel disengaging the manual valve from the peg.
29. Reposition the manual valve rearwards into the valve body.

**⚠ Caution:** When carrying out the following operation, be careful not to bend the manual control valve operating peg.

30. Remove the nut securing the manual control valve lever (Illustration 8).

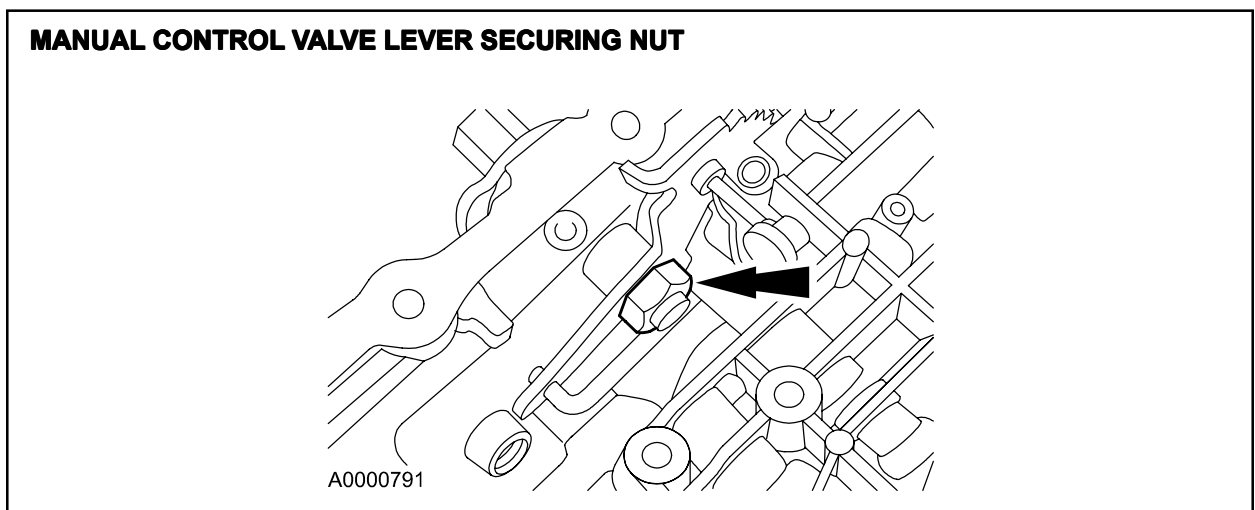

ILLUSTRATION 8

**Note:** Lever front stop will contact the main case.

31. Disconnect the manual control lever from the shaft.
32. Remove the manual control lever from the park pawl actuating rod (Illustration 9).

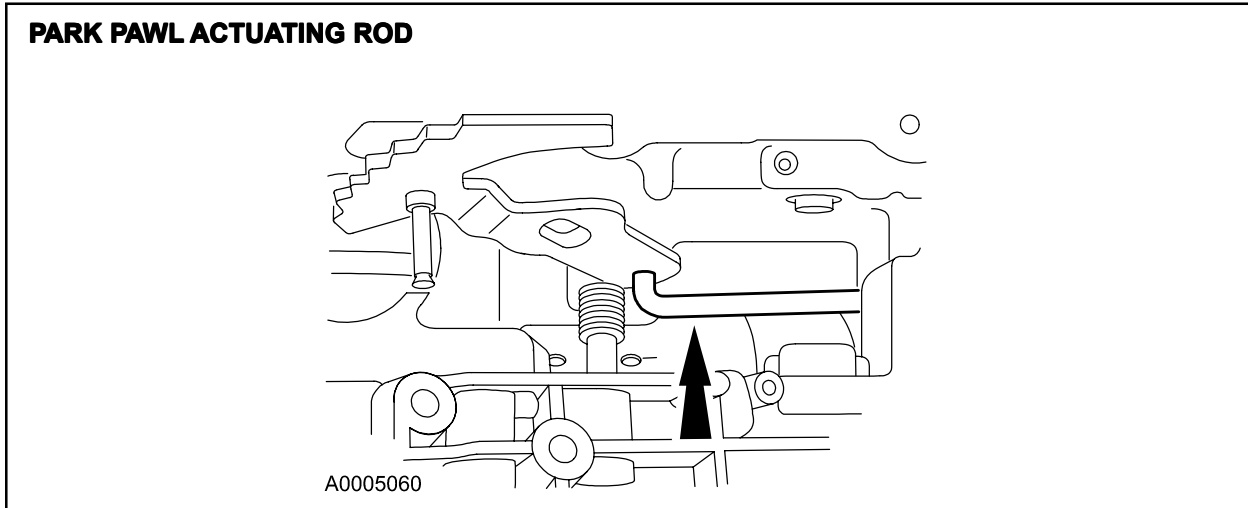

ILLUSTRATION 9

33. Install the new manual control lever to the park pawl actuating rod (Illustration 10).

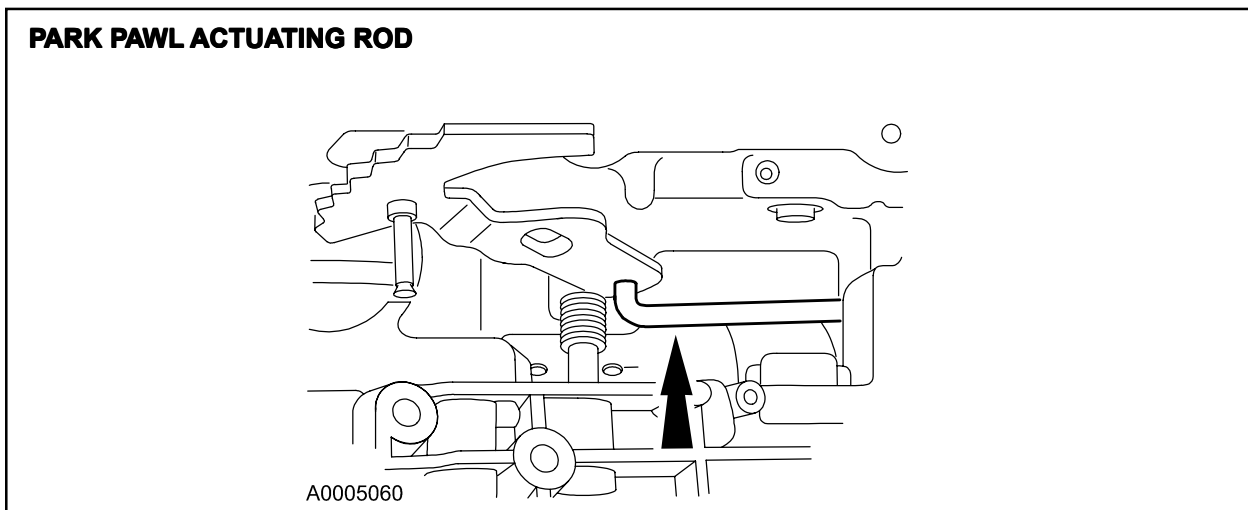

ILLUSTRATION 10

34. Connect the manual control lever to manual control lever shaft and engage on flats.
35. Install but do not tighten the manual control lever securing nut.
36. Reposition manual control lever shaft into main case.
37. Rotate the manual control shaft until the internal lever rear stop contacts main case.

**⚠ Caution:** During the following operation, be careful not to bend the manual control valve operating peg.

38. Final-tighten the manual control lever securing nut to 48 Nm (Illustration 11).

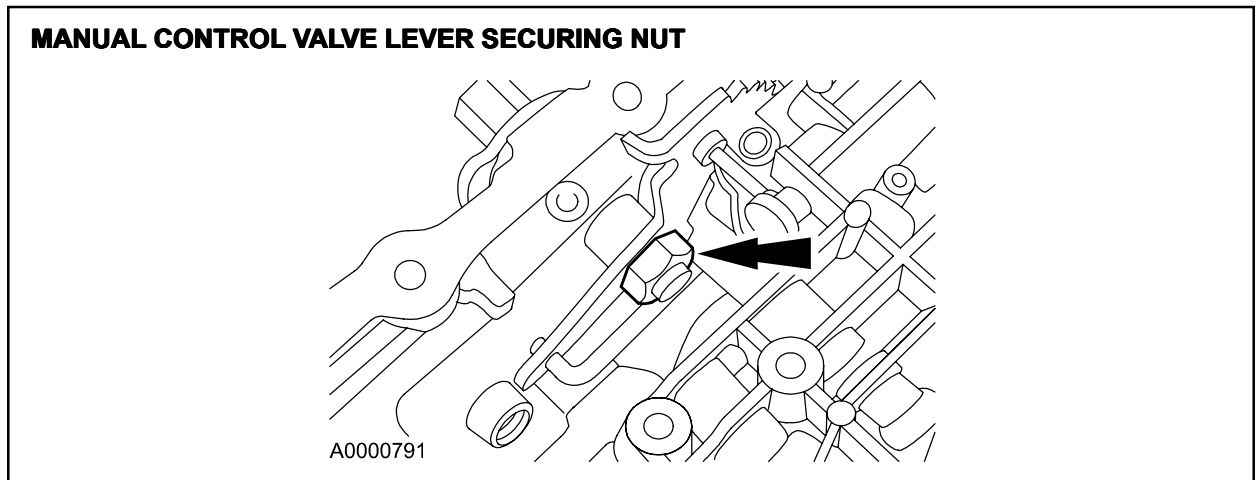

ILLUSTRATION 11

39. Reposition the manual control valve forward from the valve body to align with the manual control lever peg.
40. Align the manual control lever shaft alignment groove with the retaining pin bore of main case.

**Note:** The shank of a new 3 mm twist drill will aid in this operation (Illustration 12).

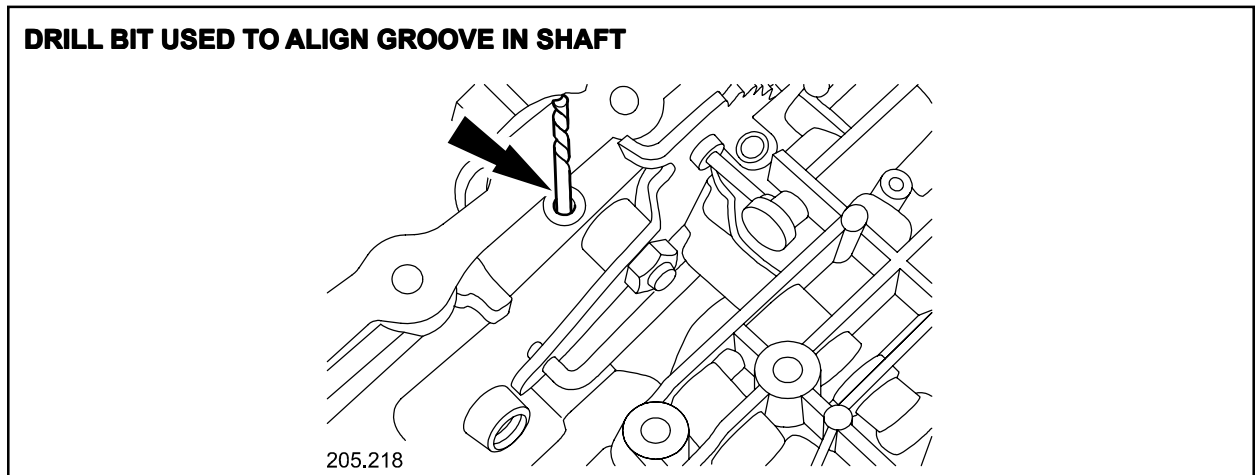

ILLUSTRATION 12

41. Install the manual control lever shaft retaining pin and drive gently into position (Illustration 13).

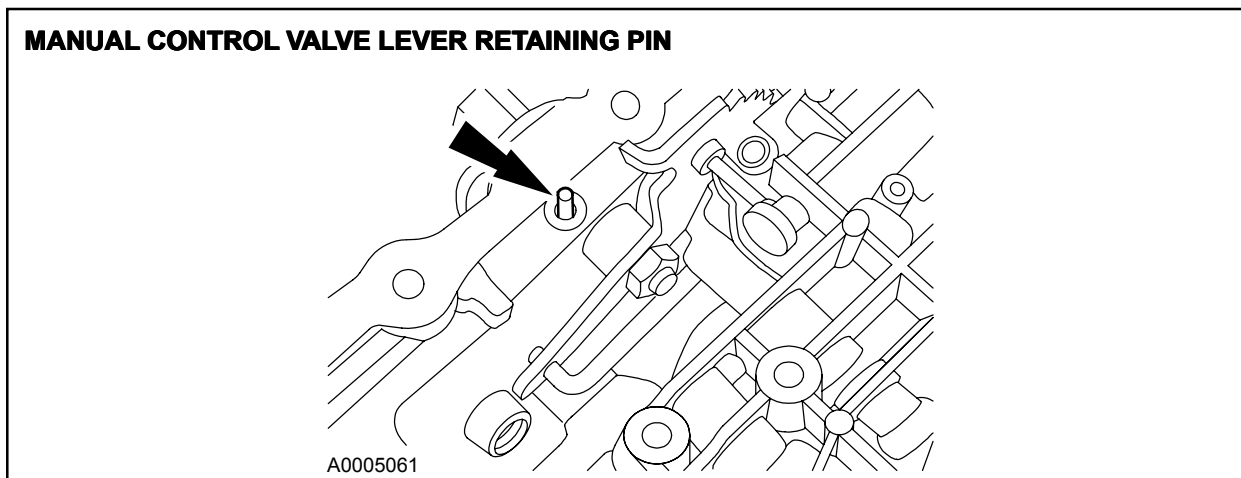

ILLUSTRATION 13

42. Align and install the manual control lever detent spring.
43. Install and fully tighten the detent spring securing bolt to 10 Nm.
44. Install new O-ring, install the solenoid block and install and tighten the solenoid block fixing bolts to 8 Nm (Illustration 14).

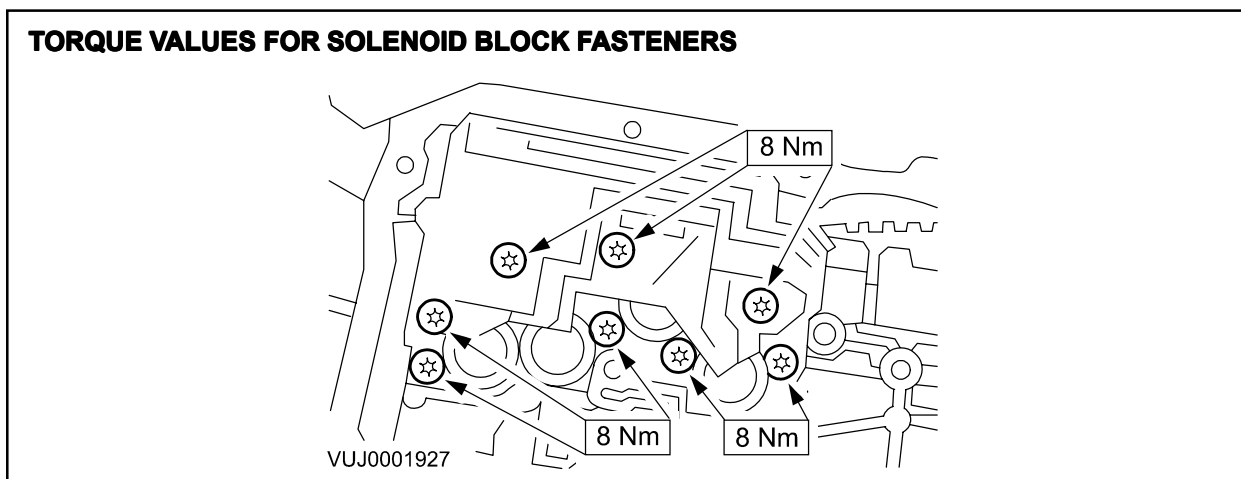

ILLUSTRATION 14

45. Connect the pressure switch electrical connector.
46. Connect the solenoid block electrical connector.
47. Install new transmission fluid filter and gasket, and install the fluid pan (see Global Technical Reference GTR Workshop Manual, section: 307-01, SRO 44.24.07).

**Note:** Ensure the manual control lever is in the neutral position. Do **NOT** carry out the refill procedure shown in the Workshop Manual SRO 44.24.07.



48. Ensure the manual control lever is in the neutral position.
49. Install the TR sensor to the manual control lever, install but do not fully tighten the TR sensor securing screws.
50. Align marks on the TR sensor (Illustration 15).

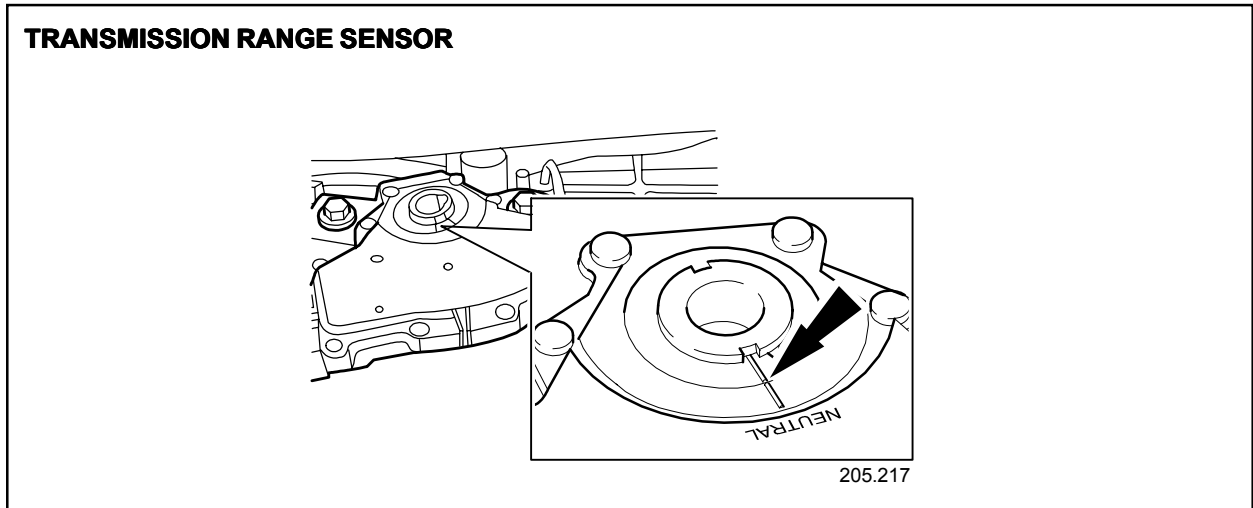

ILLUSTRATION 15

51. Final tighten the TR sensor securing screws.
  52. Connect the TR sensor electrical connector.
- Working with an assistant:
53. Raise rear of the transmission by hand and reposition the jack under the transmission fluid pan.
- Working alone:
54. Place a new gasket on the extension housing, install the extension housing on the transmission and install and fully tighten securing bolts.
  55. Raise transmission jack to align the transmission to the correct position.
  56. Install and fully tighten rear mounting securing bolts.
  57. Lower the transmission jack and return transmission jack to the storage area.
  58. Install transmission extension housing seal (see Global Technical Reference GTR Workshop Manual, section: 307-01, SRO 44.20.18).
  59. Connect battery (see Global Technical Reference GTR Workshop Manual, section: 414-01).
- On vehicles from VIN L00600 to M30850 only, continue from step 59, on vehicles from M30851 continue from step 72.
60. From under the vehicle, reposition the selector cable outer casing convoluted heat protection away from the crimp.
  61. Visually check to ensure the outer casing has not moved from the crimp. If the cable has moved, replace the selector cable.

62. Push and pull the outer casing to ensure it does not move within the crimp (Illustration 16). If the cable has moved, replace the selector cable.

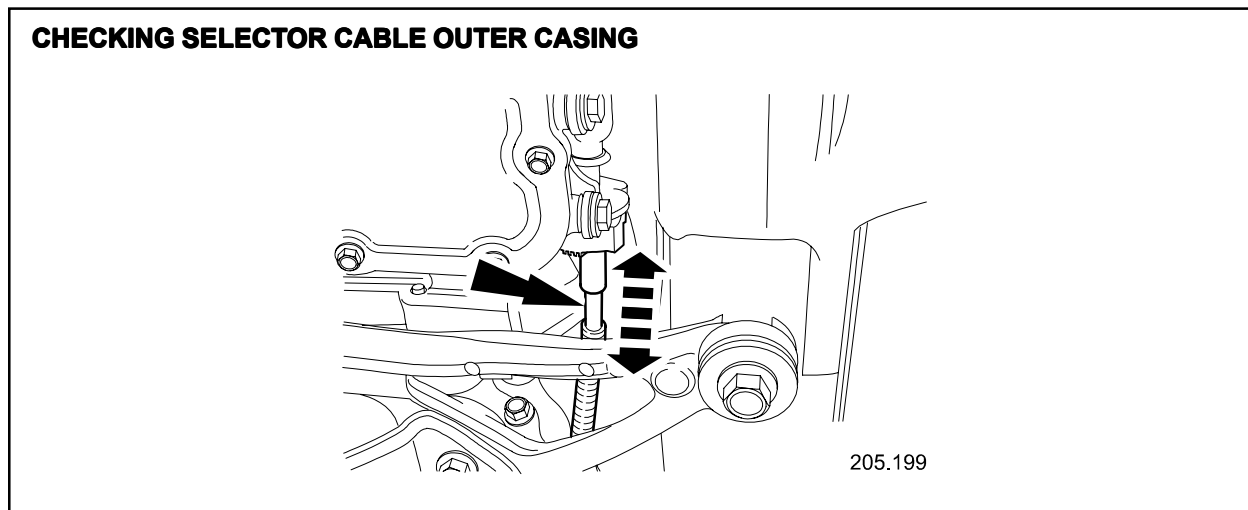

ILLUSTRATION 16

63. Reposition the outer casing convoluted heat protection to original condition.
64. Reposition the manual control lever so the ball pin is furthest away from the inner cable end.
65. Remove floor console (see Workshop Manual section: 501-12).
66. From inside the vehicle, visually check to ensure the selector cable outer casing has not moved from the crimp. If the cable has moved, replace the selector cable.
67. Push and pull the outer cable to ensure it does not move within the crimp. If the cable has moved, replace the selector cable.
68. Raise the gearshift lever locking solenoid plunger to allow operation of the gear shift lever.
69. Operate the gearshift lever to check for smooth operation of inner cable, If the cable does not move smoothly, replace the selector cable.

**Note:** Leave the gear shift lever in the 'N' position.

70. Install floor console (see Workshop Manual section: 501-12).
71. From underside of vehicle, reposition the manual control lever to the 'N' position.
72. On all vehicles, connect the inner selector cable to the transmission manual control lever ball pin.
73. Remove the transmission filler plug.
74. Fill transmission with fluid using a suitable syringe.

**Note:** It is not possible to get all of the fluid into the transmission at this stage.

75. Reposition the gearshift lever to the 'P' position.

76. Position WDS alongside vehicle, switch Portable Test Unit (PTU) 'ON' and allow software to load.

**Note:** Ensure WDS is loaded with software release JTP 759/30 or later.

77. Connect PTU to vehicle using diagnostic cable.
78. Enter VIN and navigate to content model screen.
79. Select 'Transmission System'.
80. Press datalogger icon tab at the top of the screen.
81. Select and view 'Transmission Oil Temperature' signal ensuring the handbrake is on, with 'P' selected, and start the engine as instructed.
82. Press tick to monitor temperature.

**Note:** The fluid level should be checked with the temperature between 26°C and 48°C.

83. With the engine at idle, move the selector lever through all the range positions several times, pausing in each one, before returning to 'P'.
84. Remove the transmission fluid level plug.
85. Check and top up with fluid until fluid drips from the level pipe every few seconds.
86. Install and tighten fluid **level** plug.
87. Install and tighten fluid **filler** plug.
88. Clean fluid residue from transmission.
89. Switch the ignition 'OFF'.
90. Switch 'OFF' PTU, disconnect from vehicle and return WDS to original location.

## Global Technical Reference (GTR) Workshop Manual Information:

Dealer access: <https://hub.franchise.jaguar.com>

Internet access: <http://www.jaguartechno.com>

### Parts Information:

<b><u>DESCRIPTION</u></b>	<b><u>PART NUMBER</u></b>	<b><u>QTY</u></b>
Transmission manual control lever	XR8 41639	1
Transmission fluid	JLM 21044	6
Transmission fluid pan gasket (from VIN L00600 to L31320)	XR8 5505	1
Transmission fluid pan gasket (from VIN L31321 to M45254)	XR8 14422	1
Transmission drain plug fiber washer	XR8 42768	1
Transmission filter assembly	XR8 5498	1
Transmission selector cable (from VIN L00600 to M30850)	XR8 33366	1
Transmission extension housing gasket	XR8 5774	1
Transmission extension housing seal	XR8 5804	1
Transmission extension housing nut	XR8 14456	1
Transmission O-ring	XR8 10082	2

### Warranty Information:

Warranty claims should be submitted quoting the information found in the table below. This will result in payment of the stated time and, where applicable parts/miscellaneous expense codes as listed.

<b>Description</b>	<b>SRO</b>	<b>Time</b>	<b>Causal Part Number</b>
Install new transmission manual control lever - VIN L00600 to M30850	44.91.29	4.1 hrs.	XR8 41639
Install new transmission manual control lever - VIN M30851 to M45254	44.91.29	3.9 hrs.	XR8 41639
Install new transmission selector cable - VIN L00600 to M30850	44.15.08	0.5 hrs.	XR8 33366