

**Front Door Replacement –
Adapting Window Regulators To New Style
Front Door – Adaptor Kit**

MODEL 2000-02 MY
S-TYPE

VIN L00001-M45255

Issue:

When an entire front door needs to be replaced on a 2000-02 MY S-TYPE, only the 2003 MY-on front doors are now supplied. Since the 2003 MY-on window regulator is **not** compatible with the older electrical system, the original 2000-02 MY window regulator must be adapted to fit the 2003 MY style front door.

An adaptor kit for this purpose is now available.

Action:

To install the window regulator adaptor kit on the new front door, follow the workshop procedure outlined below.

MODIFICATION PROCEDURE PRIOR TO PAINTING DOOR

1. Place new door on suitable surface.

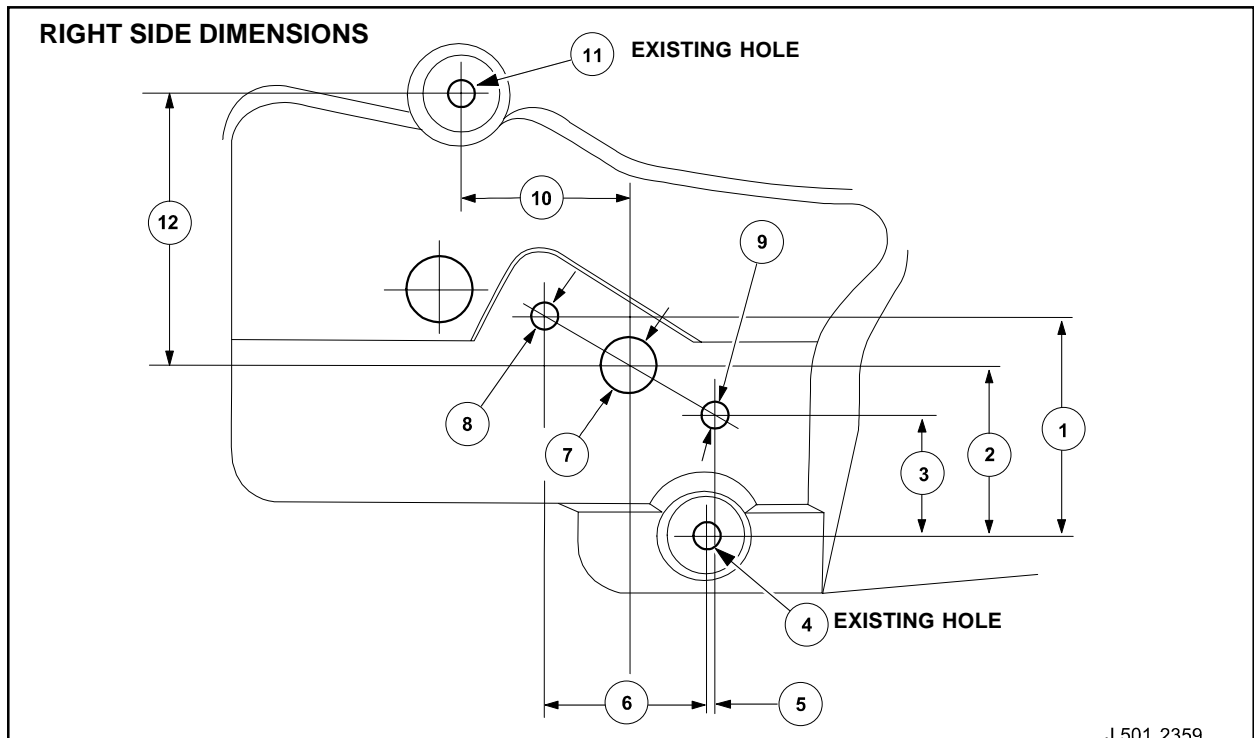

J.501.2359

ILLUSTRATION 1

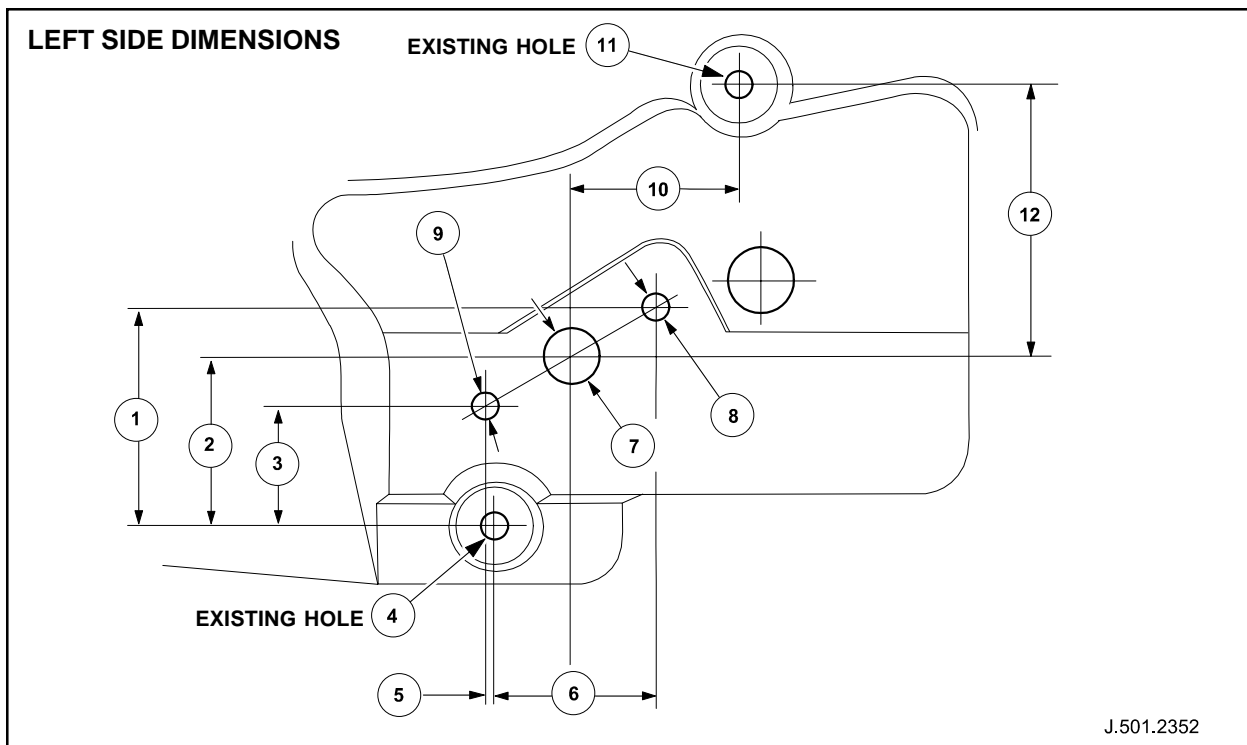

ILLUSTRATION 2

Dimensions in Illustration 1 and Illustration 2

- 1 = 83 mm vertical 2 = 64 mm vertical 3 = 45.5 mm vertical
- 5 = 3 mm lateral 6 = 62 mm lateral 10 = 65 mm lateral
- 12 = 102.5 mm vertical

Measure and mark positions of three holes to be drilled.

Pilot hole 7

- Measure 65 mm from center of hole 11 as indicated at dimension 10 Illustration 1 and 2.
- Measure 102.5 mm from center of hole 11 as indicated at dimension 12 Illustration 1 and 2.

Pilot hole 8

- Measure 83 mm from center of hole 4 as indicated at dimension 1 Illustration 1 and 2.
- Measure 62 mm from center of hole 4 as indicated at dimension 6 Illustration 1 and 2.

Pilot hole 9

- Measure 45.5 mm from center of hole 4 as indicated at dimension 3 Illustration 1 and 2.
- Measure 3 mm from center of hole 4 as indicated at dimension 5 Illustration 1 and 2.

- Carefully center punch holes (7, 8 and 9) to be drilled at marked positions.
- Pilot drill three 3 mm holes (7, 8 and 9).
- Using suitable hole saw, open out center pilot hole (7) to 20 mm diameter.
- Using suitable drill, open out remaining pilot holes (8 and 9) to 8 mm diameter.
- De-burr three drilled holes.
- Remove all drilling swarf.

Note: Apply suitable zinc enriched paint to bare metal surfaces created during process and allow to dry.

PROCEDURE AFTER PAINTING DOOR

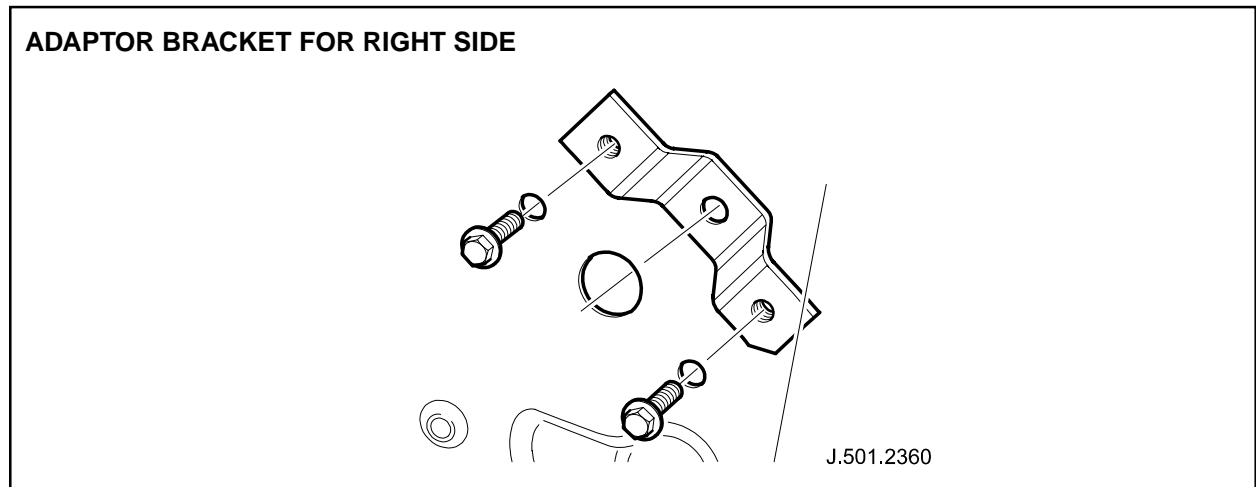

ILLUSTRATION 3

- Install bracket provided to the inside of the door (illustration 3 & 4).

Note: Chamfered corner of bracket to be positioned towards bottom of door.

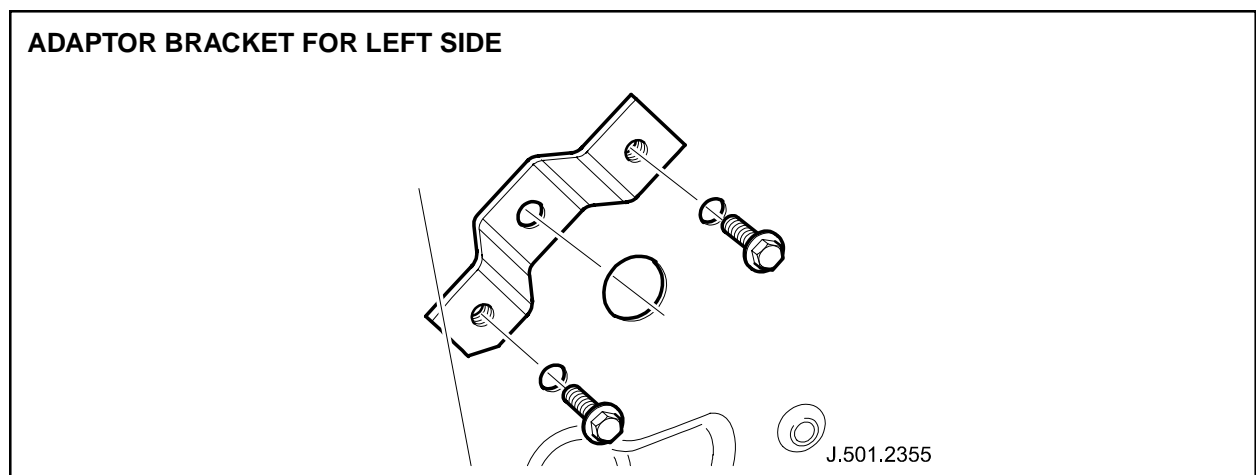

ILLUSTRATION 4

2. Install but do not tighten bracket to door securing screws provided.
3. Install window regulator assembly.
4. Tighten bracket to door securing screws.
5. In turn, remove backing paper from adhesive patches.
6. Install 25 mm diameter patches over holes 4 and 11 (Illustration 1).
7. Install 50 mm diameter patch over 20 mm diameter drilled hole 7 (Illustration 1).

Note: This parts/labor time cannot be claimed as warranty when the regulator support bracket is fitted to doors of cars undergoing an accident or similar repair.

Parts Information:

<u>DESCRIPTION</u>	<u>PART NUMBER</u>	<u>QTY</u>
Window regulator adaptor kit (right hand)	XR8 38260	1
Window regulator adaptor kit (left hand)	XR8 38261	1

Warranty Information:

Warranty claims should be submitted quoting the information found in the table below. This will result in payment of the stated time and, where applicable parts/miscellaneous expense codes as listed.

Description	SRO	Time	Causal Part Number	Causal Part Description
Install window regulator adaptor kit (right hand)	76.94.17	0.2 hrs.	XR8 38260	Window regulator adaptor kit (right hand)
Install window regulator adaptor kit (left hand)	76.94.17	0.2 hrs.	XR8 38261	Window regulator adaptor kit (left hand)