



X-TYPE

DATE 09/01

XT206-01

SERVICE

TECHNICAL BULLETIN

Malfunctioning Brake Vacuum Pump – Remove Pump – Procedure

MODEL 2002 MY-ON
X-TYPE
VIN C00001-ON

Issue:

This Technical Bulletin has been issued to provide a procedure for removing the brake vacuum pump used on early X-TYPE series vehicles in the event of a malfunction. With the current engine calibration, the vacuum pump is unnecessary.

Action:

In case there is a **fault** with brake vacuum pump, there is no need to repair or replace the pump. Remove the vacuum pump following the procedure outlined below.

REMOVAL PROCEDURE

1. Open hood and place covers over the fenders.
2. Remove battery cover.
3. Note customer preferences.
4. Disconnect the vehicle battery. (See Workshop Manual, JTIS CD ROM section 414-01).

Warning: After the battery has been disconnected, wait for one minute for the air bag system to disarm.

5. Remove the vehicle battery. (See Workshop Manual, JTIS CD ROM section 414-01, SRO 86.15.01).
6. Disconnect the battery box drain tube from its retaining clip under the vehicle.
7. Remove the battery box. (See Workshop Manual, JTIS CD ROM section 414-01, SRO 86.15.11).

Note: Note the routing of the drain tube.

8. Disconnect the vacuum hose from the vacuum pump control module.

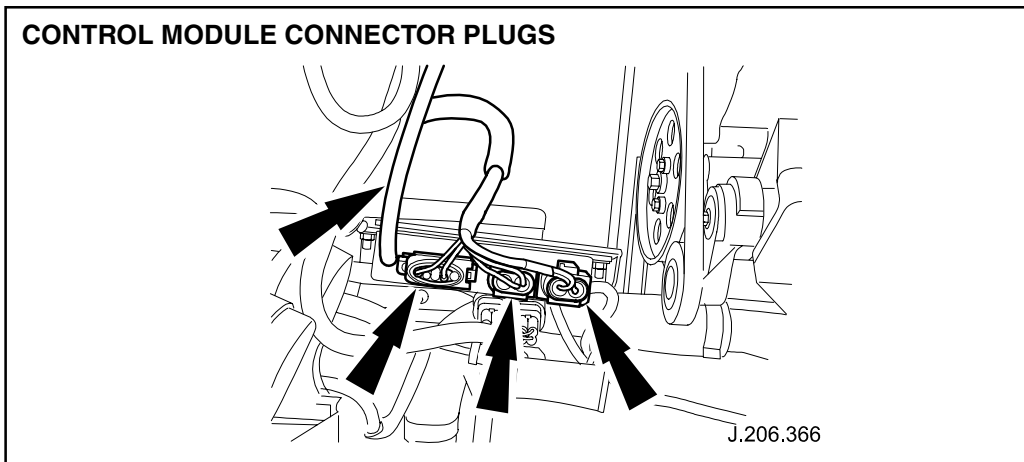

ILLUSTRATION 1

9. Disconnect the control module connector plugs (Illustration 1).

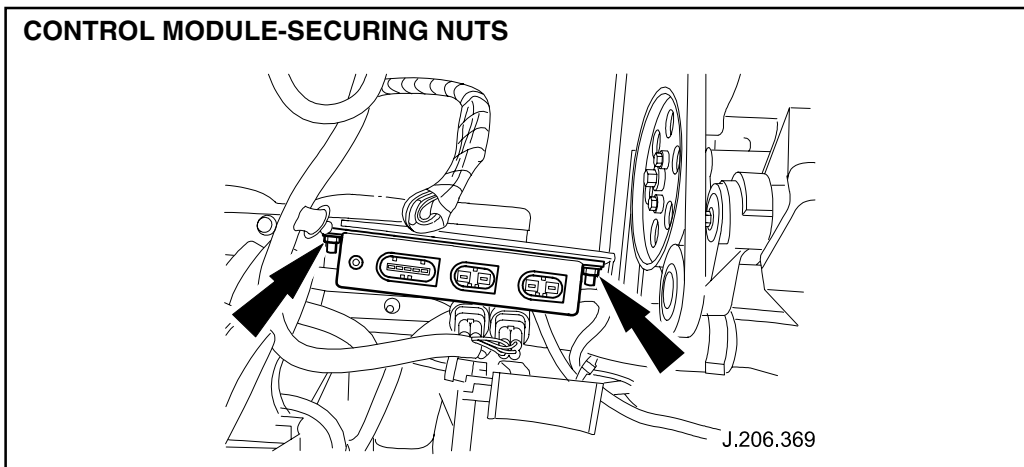

ILLUSTRATION 2

10. Remove the control module-securing nuts (Illustration 2).
11. Remove the control module and place aside.
12. Disconnect the vacuum hose and clip from the battery cable.

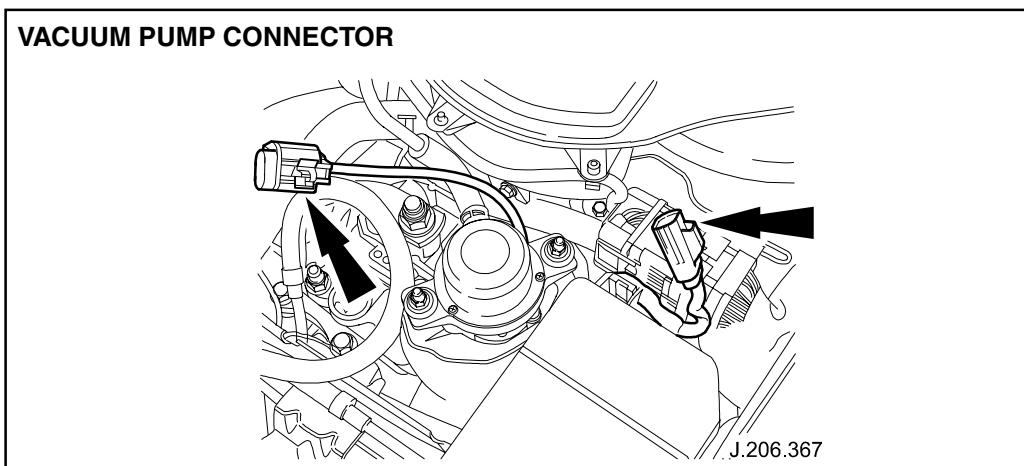

ILLUSTRATION 3

13. Disconnect the vacuum pump connector (Illustration 3).

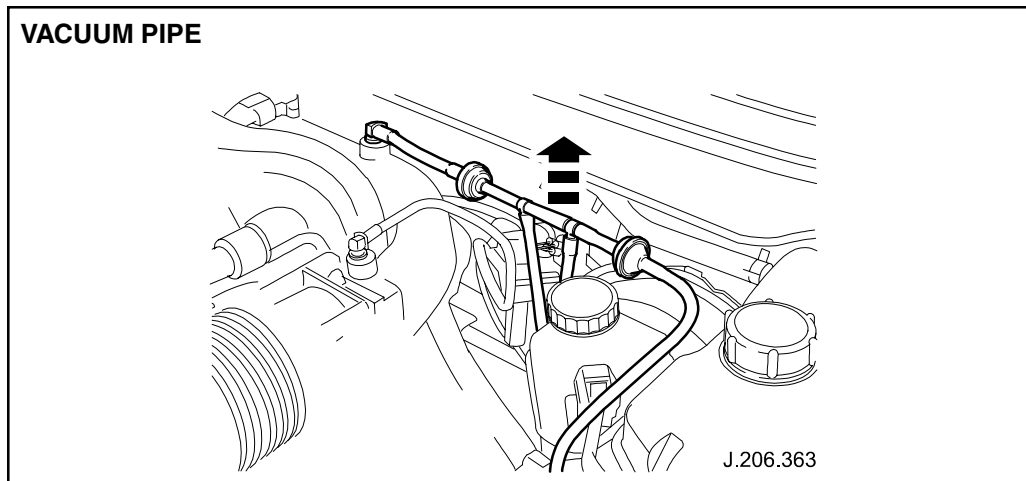

ILLUSTRATION 4

14. Disconnect the vacuum pipe from the brake booster and intake manifold and remove the pipe (Illustration 4).

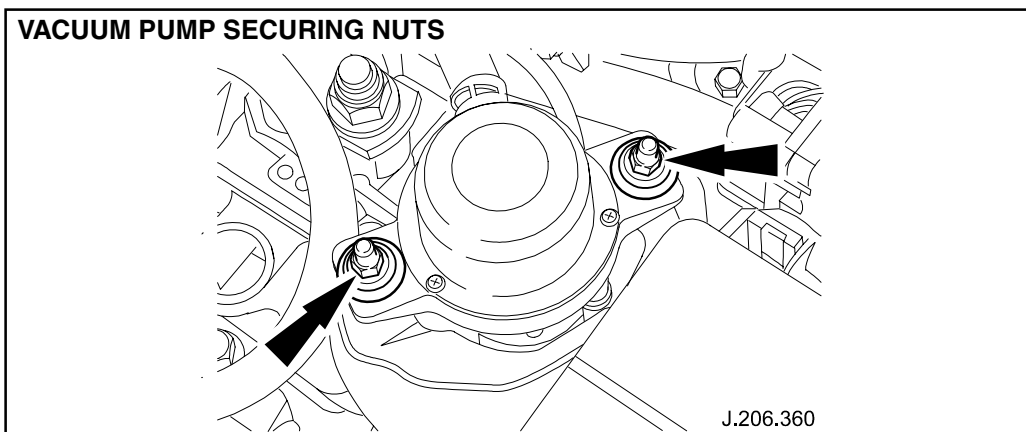

ILLUSTRATION 5

15. Remove the vacuum pump securing nuts (Illustration 5).
16. Remove the vacuum pump, pipe and hose assembly from vehicle and place aside.

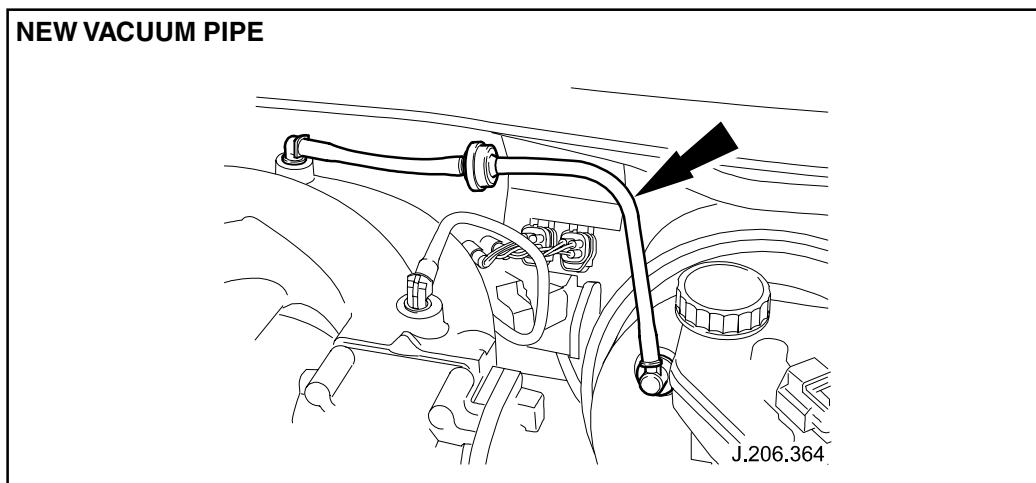

ILLUSTRATION 6

17. Install the new vacuum pipe connecting to the intake manifold and the brake booster (Illustration 6).

18. Cut, remove and discard the connector from the vacuum pump harness.
19. Carefully cut back and remove the harness sheathing as required.
20. Reposition the vacuum pump control module harness upwards for access.
21. Cut, remove and discard the three connectors from the vacuum pump control module harness.
22. On each of the three cut wires, fit heat shrink tubing (418-104) from the harness repair kit halfway onto end of each cut wire (Illustration 7).

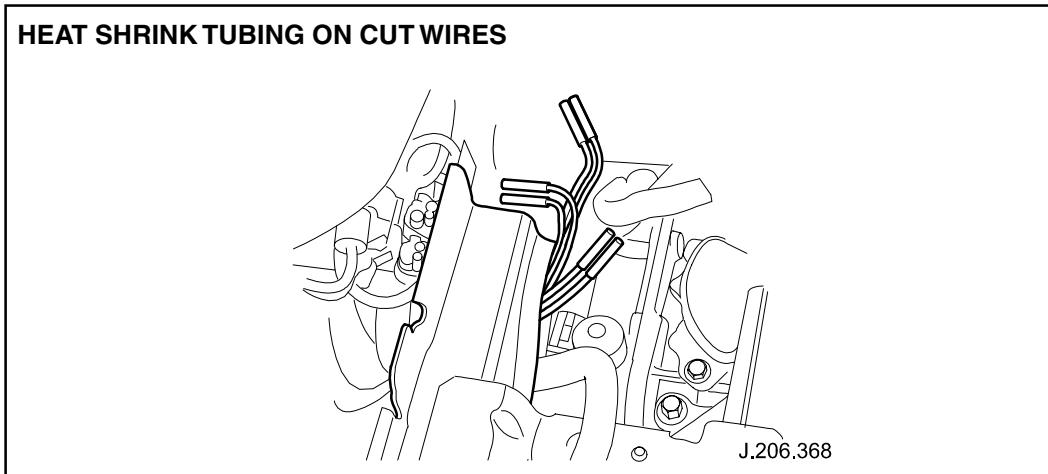

ILLUSTRATION 7

23. Using a hot air gun, shrink the tubing onto each cut wire.
24. Squeeze tubing to seal each cut wire.

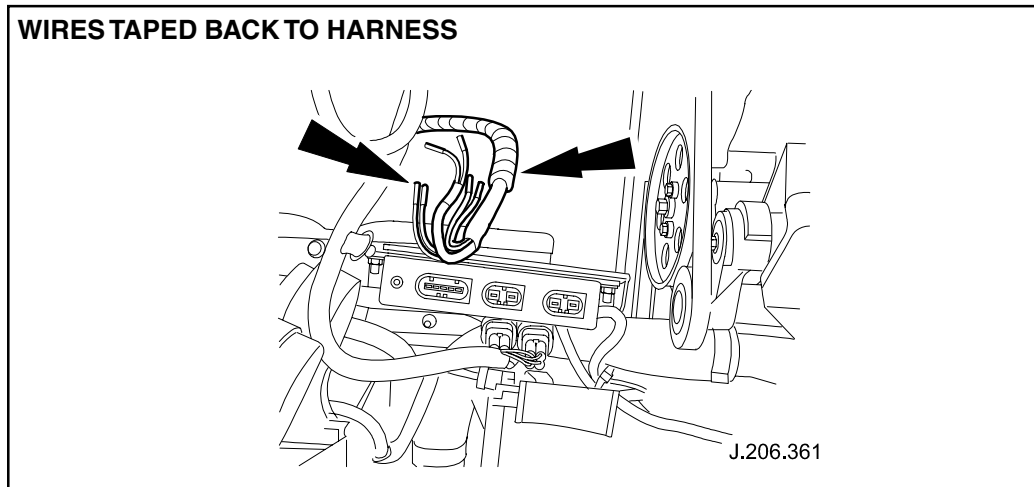

ILLUSTRATION 8

25. Fold back and tape the wires to the end of the vacuum pump harness (Illustration 8).
26. Stow the taped vacuum pump harness.

27. Fold back and tape the wires to the end of vacuum pump control module harness.
28. Install and seat the battery box while routing the drain tube as noted during battery box removal.
29. Secure the battery box drain tube to its retaining clip under the vehicle (Illustration 9). See Workshop Manual, JTIS CD ROM section 414-01, SRO 86.15.11.

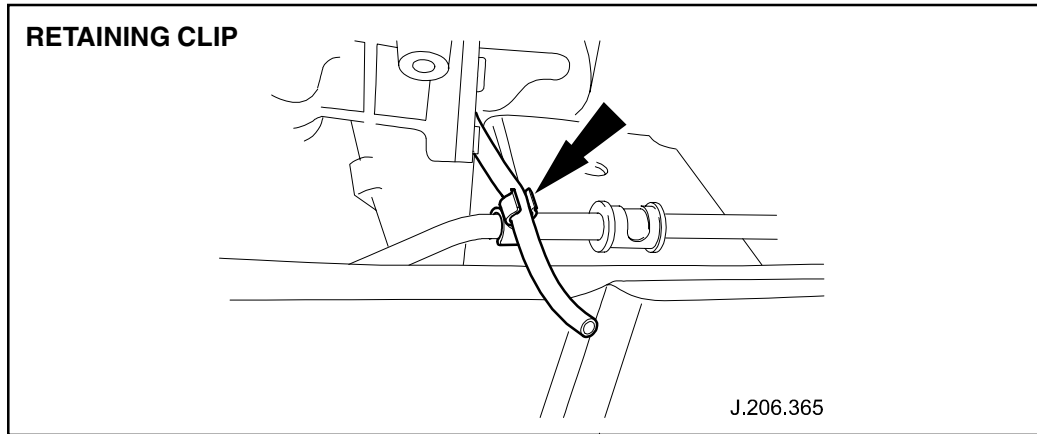

ILLUSTRATION 9

30. Install the vehicle battery. See Workshop Manual, JTIS CD ROM section 414-01, SRO 86.15.01.
31. Reconnect the vehicle battery. (See Workshop Manual, JTIS CD ROM section 414-01).
32. Install the battery cover.
33. Cut two 35 mm long pieces from the original vacuum pipe that connected the booster to the intake manifold.
34. To enhance appearance, slide two pieces of the cut vacuum pipe on to the vacuum mounting studs (Illustration 10).

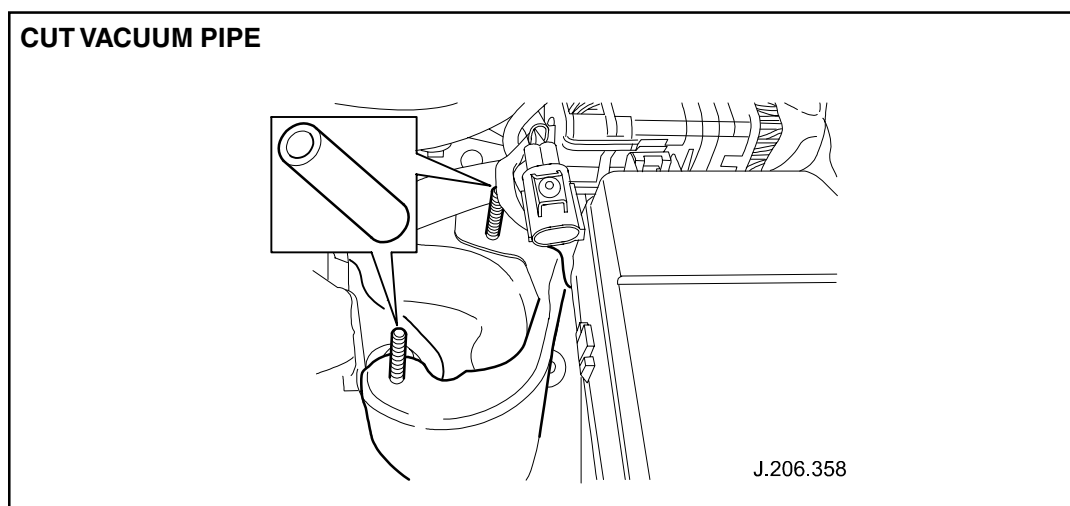

ILLUSTRATION 10

35. Remove the fender protection covers and close the hood.
36. Reset the customer preferences.

Parts Information:

| <u>DESCRIPTION</u> | <u>PART NUMBER</u> | <u>QTY</u> |
|--------------------------------------|--------------------|------------|
| Tube assembly – brake booster vacuum | C2S 17552 | 1 |

Warranty Information:

| <u>FAULT</u> | <u>R.O.</u> | <u>DESCRIPTION</u> | <u>TIME</u> |
|--------------|---------------|-------------------------------------|------------------|
| <u>CODE</u> | <u>NUMBER</u> | | <u>ALLOWANCE</u> |
| HD GB 42 | 70.91.23 | Brake booster vacuum pump - disable | 0.6 hrs. |