

# TECHNICAL BULLETIN



## Fuel Pump Modules – XJR-S – Install Modification Kit – Service Action S385

**19-27**

MODEL XJR-S

DATE 10/94

From: VIN 187460

### ISSUE:

The Fuel Pump Modules of XJR-S vehicles were changed in production at VIN 187460.

### ACTION:

Upgrade XJR-S vehicles with the revised Fuel Pump Modules as necessary.

All XJR-S vehicles must be examined at the next service opportunity to determine if they are part of this action. If the vehicle's VIN appears on the S385 SERVICE ACTION VIN LIST (page 4) check the underside of the hood panel for an S385 label.

If the vehicle is on the list and there is no S385 label under the hood, perform the following Service Action

### Procedure:

**WARNING: LIQUID FUEL AND FUEL VAPOR WILL BE PRESENT DURING THE FOLLOWING OPERATIONS. BE SURE THAT THE WORK AREA IS WELL VENTILATED. FOLLOW ALL SAFETY PRECAUTIONS DETAILED IN THE SERVICE MANUAL FUEL SYSTEM SECTION.**

1. Remove the in line fuel pump fuse (light blue, 15 amp), located at the right rear on the ECM bracket.
2. Run the engine until it stalls. Crank the engine for several seconds to make sure the fuel system is completely depressurized.

**CAUTION: DO NOT remove the fuel pump relay to depressurize the fuel system or DTC 22 will flag and be stored in the ECM. If this occurs call the Jaguar Technical Hotline for instructions.**

3. Record all preset radio stations (including X-men). Disconnect and remove the battery from the vehicle.
4. Remove the fuel tank following XJS Service Manual instructions in Service Manual section 19.55.01.

5. Disconnect the evaporative loss flange hoses. Release the flange retaining ring using Jaguar special tool JD 174.

**WARNING: OPERATIONS INSIDE THE FUEL TANK MUST ONLY BE PERFORMED USING JAGUAR SPECIAL TOOL JD 175**

6. Label, and remove the fuel supply and return hoses from the fuel pump modules.

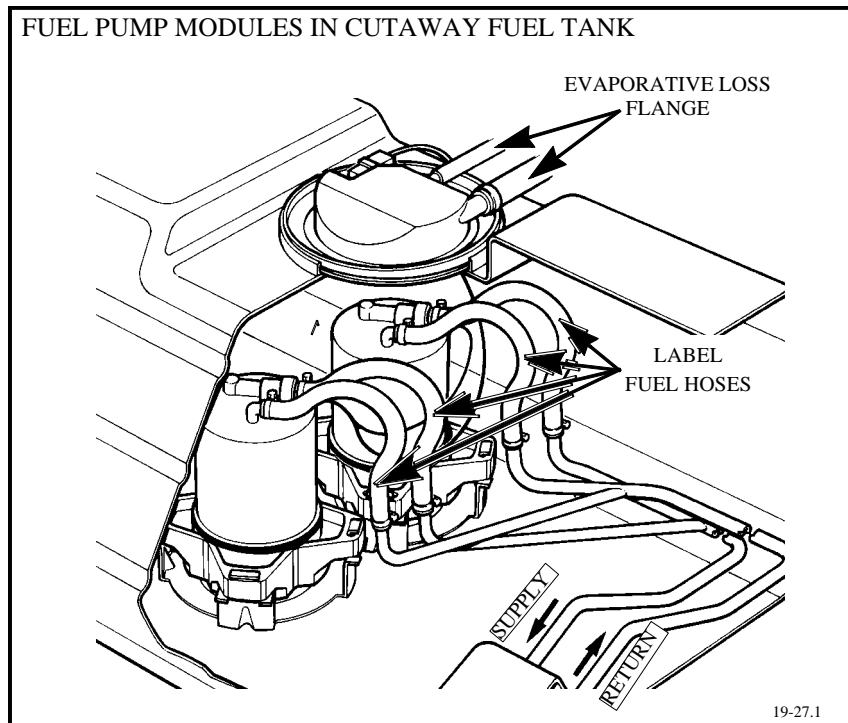

ILLUSTRATION 1

7. Cut and remove the tie straps on the fuel pump module mounting rubbers.
8. Separate the fuel pump modules from the mounting rubbers and remove both from the tank.

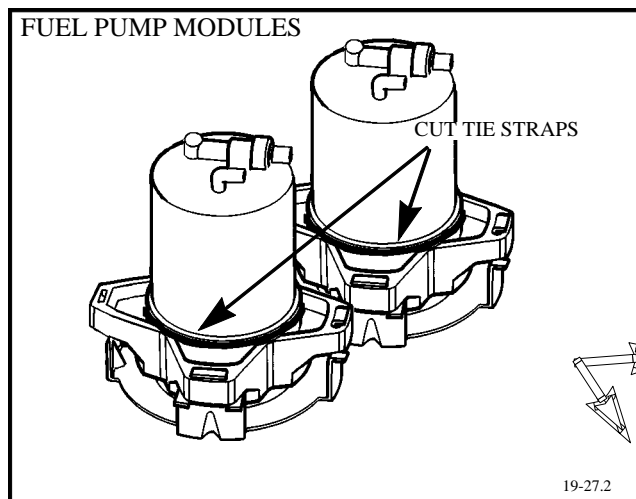

ILLUSTRATION 2

9. Confirm that the bottom edge of the mounting rubbers is formed to clear the elongated fuel pickup filters of the new pump modules. If the mounting rubbers will not clear the new pump modules' filters, install new mounting rubbers (P/N EBC 10124).
10. Place the mounting rubbers in the fuel tank.
11. Place the new pump modules in the fuel tank.

**CAUTION:** Do not bend or kink the module fuel pick-up filters.

12. Align the module and mounting rubber location lugs, seat the modules into the mounting rubbers and install new tie straps.
13. Fit the module/mounting rubber assembly to the fuel tank base and reconnect the fuel feed and return hoses. Tighten the hose clamps with tool JD 175.
14. Install the new evaporative loss flange and sealing ring.
15. Remove the original fuel tank part number label and affix the modified fuel tank part number label in its place.
16. Reinstall the fuel tank using the new fuel line and "O" rings for the new filler neck gaiter.
17. Remove and discard the vent pipe from the old evaporative flange and replace the trunk floor grommet with the new blanking plug,
18. Remove the fuel pump link harness from the chassis harness and replace with the new link harness.

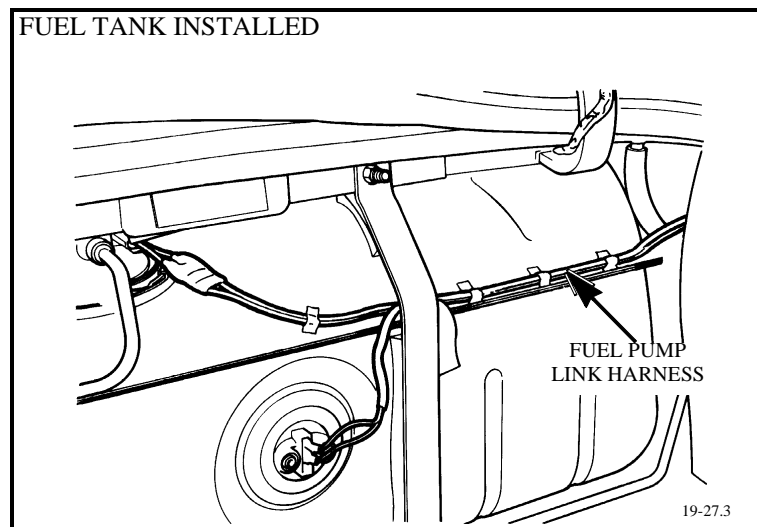

ILLUSTRATION 3

19. Install the new 25 amp fuel pump fuse and replace the existing fuse label with the new one.
20. Reinstall the battery and trunk interior panels. Program the preset radio stations and reset the clock.
21. Clean the left rear underside corner of the hood panel and affix the S385 label.

**PARTS INFORMATION:**

MODEL	DESCRIPTION	PART NUMBER
Coupe	Modification Kit	SPM 6041
	Filler Neck "O" Ring	C 46157
	Filler Filler Hose	C 43958
Convertible	Modification Kit	SPM 6042
	Filler Neck "O" Ring	CAC 7509
	Fuel Filler Hose	CBC 8703/3

**WARRANTY INFORMATION:**

**Service Action S385**

<u>VEHICLE</u>	<u>SUMMARY CODE</u>	<u>DESCRIPTION</u>	<u>TIME ALLOWANCE</u>
XJR-S Convertible Model Code 2104 From VIN 187460	BU	Install modification kit S385	2.75 hrs.
XJR-S Coupe Model Code 4060 From VIN 187460	BV	Install modification kit S385	2.75 hrs.

**CLAIM SUBMISSION PROCEDURE:**

Warranty summary codes have been assigned to this service action in order to simplify claim submission. The dealership will be reimbursed the labor time allowance and parts as indicated.

**DCS Dealers**

Submit claims using the appropriate summary code for the vehicle model and work performed. Follow standard campaign submission procedures.

**Non-DCS Dealers**

Submit claims on the Recall Campaign Summary form W-25. Enter the appropriate summary code for the vehicle model and work performed in the Repair Code column. Do not use the W-1 warranty claim form.

S385 SERVICE ACTION VIN LIST

<u>XJR-S COUPE</u>		<u>XJR-S CONVERTIBLE</u>
185339	186735	185475
185355	196753	186589
185527	186765	186601
185530	186799	186619
186491	186820	186629
186505	186828	186637
186535	186850	186667
186552	186862	186679
186566	186870	186713
186596	186879	186717
186612	186902	186746
186624	187334	186772
186632	187412	186796
186654		186959
186706		186981
186710		187315
186731		187459