

# TECHNICAL BULLETIN



## Intermittent High Idle – Replace Throttle Return Springs

19-33

MODEL XJ12 (6.0L) 1994 MY

DATE 7/95

VIN 673299-708757

### ISSUE:

Some 1994 MY XJ12 Sedan Range vehicles may experience an intermittent high idle speed of approximately 900 rpm (normal idle speed, 750 rpm in neutral). This condition occurs when slowly returning the throttle to the idle position.

Revised throttle springs with increased preload were installed on all 6.0L engines beginning with 1995 MY production.

### ACTION:

If customers of 1994 MY XJ12 vehicles complain of intermittent high idle speed, replace the existing throttle return springs with two revised springs (part number NAC 3030AB) as follows:

1. Remove throttle return spring from the throttle body, Illustration 1.
2. Install the new spring first to the bracket, then to the throttle lever.
3. Repeat the procedure on the throttle body on the opposite bank.
4. Check for correct throttle return operation.

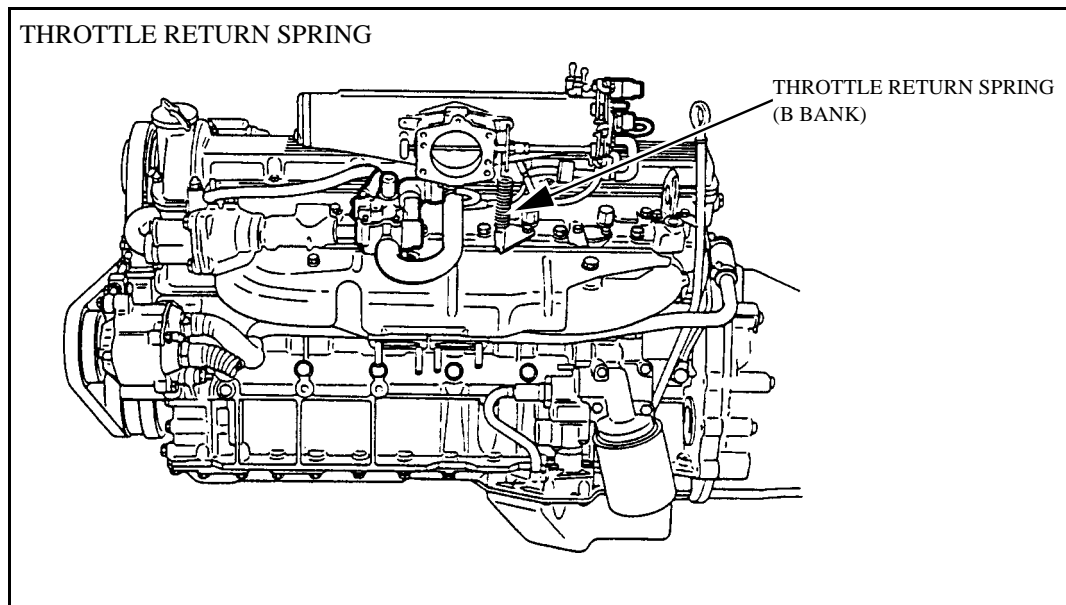

ILLUSTRATION 1

PARTS INFORMATION:

<u>DESCRIPTION</u>	<u>PART NUMBER</u>	<u>QTY</u>
Throttle return spring	NAC 3030AB	2

WARRANTY INFORMATION:

<u>MODEL</u>	<u>FAULT CODE</u>	<u>R.O. NUMBER</u>	<u>DESCRIPTION</u>	<u>TIME ALLOWANCE</u>
Sedan (6.0L) Range	CD KF NS	10.10.99	Replace throttle return springs	0.10 hrs.