

TECHNICAL BULLETIN



ZF Automatic Transmission – Noise in Reverse After Cold Start in Cold Weather – Repair Procedure

44-25

MODEL All (4.0L)

DATE 3/95

Sedan (4.0L) RangeUp to VIN 720649

XJS (4.0L) RangeUp to VIN 194774

ISSUE:

Noise when reverse gear is selected or the vehicle is driven slowly in reverse following a cold start during cold weather.

All 4.0L automatic transmission equipped vehicles up to the VINs listed below may be effected. The noise is caused by air circulating with the cold transmission fluid. The noise has no detrimental effect on the transmission.

Sedan (4.0L) Range

UP TO VIN 720649

XJS (4.0L) Range

UP TO VIN 194774

Modified transmissions are fitted during production beginning with VINs 720650 (Sedan Range) and 194775 (XJS Range).

ACTION:

If a customer complains of a transmission noise after cold start during cold weather on a vehicle within the VIN range, follow the appropriate procedure described below.

SEDAN (4.0L) RANGE UP TO VIN 720649 - REPAIR PROCEDURE

1. Drive the vehicle until it is at normal operating temperature (10 to 15 miles minimum). Immediately check the HOT transmission fluid level with the engine idling and the transmission in PARK.
Set the fluid level to the MAX HOT mark on the dipstick.
2. Park the vehicle overnight to become thoroughly cold.
3. Start the vehicle without touching the accelerator. Select reverse and listen for transmission noise. Drive slowly in reverse and listen for transmission noise.
4. If the transmission is noisy in reverse when cold, remove the transmission valve body (valve block) following the instructions in the Service Manual, Section 44.

5. Remove the 4 screws shown in Illustration 1. Replace the existing torque converter control valve with a new control valve (part number NHD 5602AA).

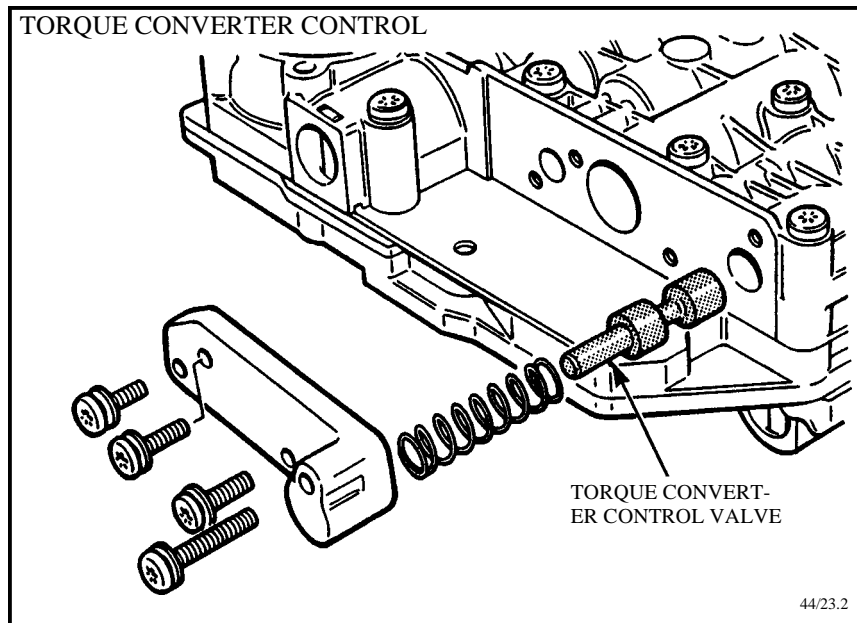

ILLUSTRATION 1

6. Reassemble the transmission. Torque the 13 valve body to transmission screws to 6 lb ft (8 Nm).
7. Drive the vehicle until it is at normal operating temperature (10 to 15 miles minimum). Immediately check the HOT transmission fluid level with the engine idling and the transmission in PARK.
Set the transmission fluid level to the MAX HOT mark on the dipstick.
8. Check the transmission for leaks.

XJS (4.0L) RANGE UP TO VIN 194774 - REPAIR PROCEDURE

1. Install a SERVICE dipstick (part number NHD 4550AA).
2. Drive the vehicle until it is at normal operating temperature (10 to 15 miles minimum). Immediately check the HOT transmission fluid level with the engine idling and the transmission in PARK.
Set the transmission fluid level to the MAX HOT mark on the SERVICE DIPSTICK.
3. Park the vehicle overnight to become thoroughly cold.
4. Start the vehicle without touching the accelerator. Select reverse and listen for transmission noise. Drive slowly in reverse and listen for transmission noise.
5. If the transmission is noisy in reverse when cold, remove the transmission valve body (valve block) following the instructions in the Service Manual, Section 44.
6. Remove the 4 screws shown in Illustration 1 above. Replace the existing torque converter control valve with a new control valve (part number NHD 5602AA).
7. Reassemble the transmission. Torque the 13 valve body to transmission screws to 6 lb ft (8 Nm).

8. Drive the vehicle until it is at normal operating temperature (10 to 15 miles minimum). Immediately check the HOT transmission fluid level with the engine idling and the transmission in PARK.
Set the transmission fluid level to the MAX HOT mark on the SERVICE DIPSTICK.
9. Check the transmission for leaks.
10. Park the vehicle overnight to become thoroughly cold.
11. Start the vehicle without touching the accelerator. Select reverse and listen for transmission noise. Drive slowly in reverse and listen for transmission noise.
12. If there is no noise, replace the SERVICE DIPSTICK with the original dipstick.
13. If the transmission noise is still unacceptable, remove the automatic transmission, starter ring gear/drive plate assembly and crankshaft adapter following the instructions in the Service Manual, Section 44.
14. Replace the existing components listed below with new components

<u>COMPONENT</u>	<u>NEW PART NUMBER</u>	<u>QTY</u>
Crankshaft adapter	NHE 1425AA	1
Starter ring gear/drive plate assy.	NHE 1428AA	1
Spacer	NHE 1431AA	1
Bolt	JZB 100046	8
Dipstick	NHD 4550AB	1
Automatic transmission	NHE 4400BA/N	1

IMPORTANT: The existing valve body **MUST** be fitted to the new transmission to maintain shift quality and harness compatibility.
 The existing dipstick tube **MUST** be fitted to the new transmission.
 A new dipstick (part number NHD 4550AB) **MUST** be fitted.
 Do not use the existing dipstick or the SERVICE DIPSTICK.

15. Drive the vehicle until it is at normal operating temperature (10 to 15 miles minimum). Immediately check the HOT transmission fluid level with the engine idling and the transmission in PARK.
16. Set the fluid level to the MAX HOT level on the new dipstick.
17. Check the transmission for leaks.

PARTS INFORMATION:

SEDAN RANGE VEHICLES

<u>DESCRIPTION</u>	<u>PART NUMBER</u>	<u>QTY</u>
Transmission torque converter control valve	NHD 5602AA	1

XJS RANGE VEHICLES

<u>DESCRIPTION</u>	<u>PART NUMBER</u>	<u>QTY</u>
Transmission torque converter control valve	NHD 5602AA	1
Service dipstick	NHD 4550AA	1
Automatic transmission	NHE 4400BA/N	1
Crankshaft adapter	NHE 1425AA	1
Starter ring gear/drive plate assy.	NHE 1428AA	1
Spacer	NHE 1431AA	1
Bolt	JZB 100046	8
Dipstick	NHD 4550AB	1

WARRANTY INFORMATION:

<u>MODEL</u>	<u>FAULT CODE</u>	<u>R.O. NUMBER</u>	<u>DESCRIPTION</u>	<u>TIME ALLOWANCE</u>
Sedan (4.0L) Range UP TO VIN 720649	FB BC KS	44.91.10	Replace transmission torque converter valve	1.75 hrs.
XJS (4.0L) Range UP TO VIN 194774	FG BC KS	44.91.10	Replace transmission torque converter valve	1.75 hrs.
XJS (4.0L) Range UP TO VIN 194774	FG BC KS	44.91.11	Replace transmission and drive plate assembly	6.35 hrs.