

# TECHNICAL BULLETIN



## Knocking Noise – Rear Subframe Bushing – Modification Procedure

**64-17**

MODEL 1988-94 MY Sedan

DATE 4/98

### ISSUE:

If a knocking noise is reported as coming from the rear suspension, it is possible that the bushing has moved out of location in the rear suspension subframe.

### ACTION:

This bulletin provides a procedure for bonding in replacement subframe bushings in case of a customer complaint of a knocking noise from the rear suspension.

#### REPLACING/BONDING SUBFRAME BUSHINGS

1. Remove the subframe from the vehicle.
2. Press out the old bushings from the subframe and thoroughly clean the bores and the surrounding areas.
3. Place the subframe on a bench and stretch a line or measuring tape through the centers of the two bores, as indicated in Illustration 1, to indicate the centerline.

**CENTERLINE OF REAR SUBFRAME BUSHING**

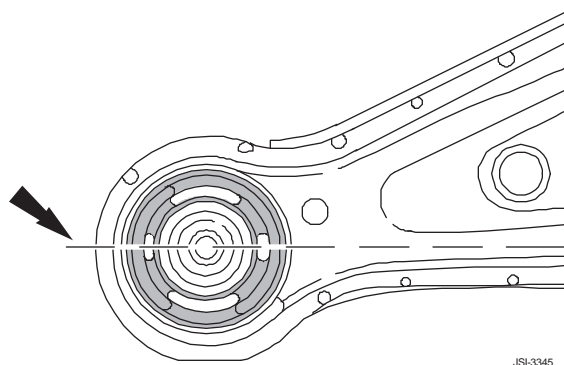

ILLUSTRATION 1

- Place small squares of masking tape on the top face of each bore, under the line or tape. Mark the centerline, with pen or pencil, on the masking tape.

**Note:** When the bushing is installed the centerline should pass through the center of the two voids in the bushing, as shown in Illustration 1.

- Use a coarse grade of emery cloth to roughen the bore surface of the subframe and the corresponding outer surface of the replacement bushing. If the surface of the bushing is not roughened sufficiently this may affect the integrity of the adhesive bond.

**Note:** The next operation requires the use of an hydraulic press. At this point practice the procedure of installing the bushing to determine the relative positions of the subframe , bushing, support and press ram to ensure that when the installation process is begun, it is completed as quickly as possible.

- Place ServiceTool JD 143A on the press bed to act as a support for the subframe during the operation to press in the bushing.
- In order to determine the starting position of the press ram, locate the subframe on JD 143A, place a spacer on the bushing to contact the outer flange. Position the bushing over the bore in the subframe. Lower the press ram until it is just possible to position the bushing between the ram and the subframe without the bushing entering the subframe. Once the press, tools and components are in position continue with the next step.
- Spray the subframe bore with the cleaning solvent, i.e. DuPont Prepsol, wipe clean with a suitable clean cloth and then spray the area again with the solvent and allow it to dry.
- Spray the face of the replacement bushing with solvent, wipe clean with a suitable clean cloth and then spray the area again with the solvent and allow it to dry.

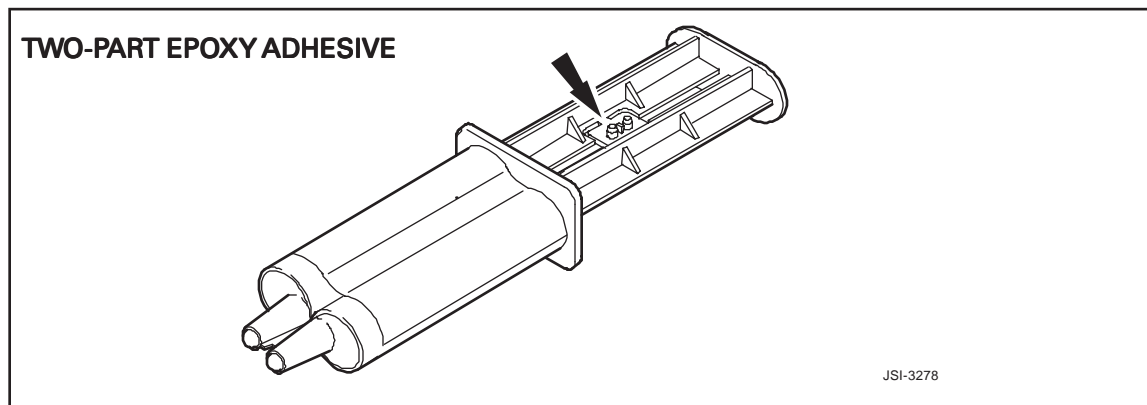

ILLUSTRATION 2

- Use a suitable 2 part epoxy such as Permatex Quick Set Auto Epoxy, part no QM50A.

11. Apply approximately one half of the adhesive, i.e. half plunger travel, to a disposable surface and then cap the nozzles.
12. Use a suitable disposable spatula to thoroughly mix the two materials.

**Note:** The adhesive curing time will depend on air temperature. Higher air temperature will accelerate the curing and reduce the time available for the installation process.

13. Apply the adhesive over the area of the bushing, shown shaded in Illustration 3, and the bore in the subframe.

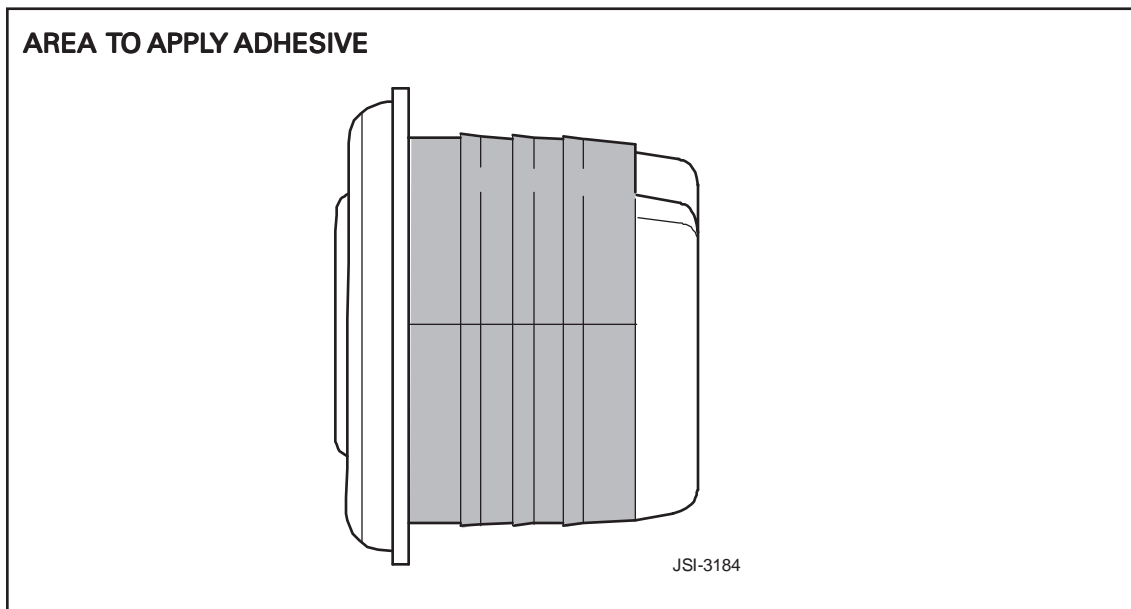

ILLUSTRATION 3

14. Take the bushing to the press and, with the spacer in position on the bushing flange, place the bushing and spacer under the press ram and then align the bushing with the centerline mark.
15. When the bushing is in position, quickly press the bushing in.

**Note:** The adhesive application and pressing operations must be completed in **4 - 6 minutes**.

16. Wipe off all excess adhesive from the subframe and the bushing. Remove the masking tape.

**POSITION OF BUSHING IN SUBFRAME**

GAP MUST NOT EXCEED 1.5 MM

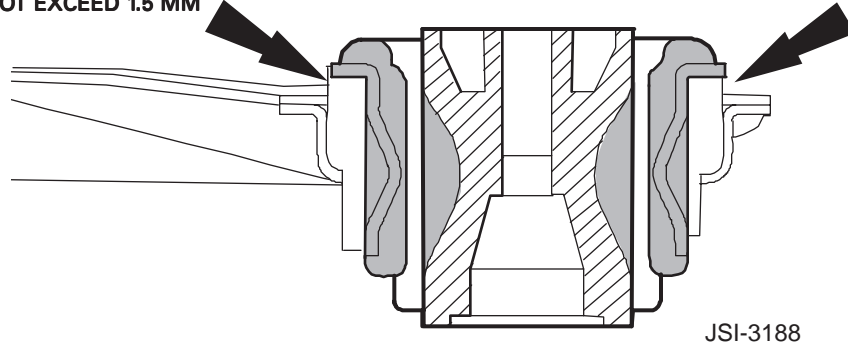

ILLUSTRATION 4

17. After the bushing has been inserted in the subframe, check for any clearance between the bushing flange and the subframe, (Illustration 4). If a gap is present, **it must not exceed 1.5 mm.**
18. Repeat the operation for the other bushing.

**Note:** The subframe assembly should not be reinstalled until at least **4 hours** have elapsed, to allow the adhesive to 'cure'.

**PARTS INFORMATION**

**DESCRIPTION**

Subframe bushing, 'Comfort' specification  
 Permatex Quick Set Auto Epoxy part no. QM50A  
 Dupont Prepsol

**PART NUMBER**

CCC 6875  
 obtain locally  
 obtain locally

**WARRANTY INFORMATION:**

<b><u>FAULT CODE</u></b>	<b><u>R.O. NUMBER</u></b>	<b><u>DESCRIPTION</u></b>	<b><u>TIME ALLOWANCE</u></b>
GM BK GC	64.91.06	Rear suspension subframe bushings - modify	2.40 hrs.