

# TECHNICAL BULLETIN



## A.B.S. Valve Block Assembly – Replace Separately

**70-27**

MODEL 1990-94 MY Sedan Range  
XJS up to VIN 198334

DATE 1/98

### ISSUE:

An A.B.S. Valve Block repair kit is available to avoid the need to replace the complete brake actuator unit.

### ACTION:

If diagnosis on the above vehicles indicates problems within the A.B.S. Valve Block, install a valve block repair kit as follows, instead of replacing the complete brake actuator unit:

1. Remove the Brake Actuator assembly, as detailed in the appropriate Workshop Manual, Section 70, SRO 70-60-06.
2. Insert plugs in any disconnected pipes and ports.

**⚠ CAUTION:** Absolute cleanliness must be observed during the following operations.

3. Empty and discard any remaining brake fluid from the actuator unit.

#### VALVE BLOCK RETAINING NUTS

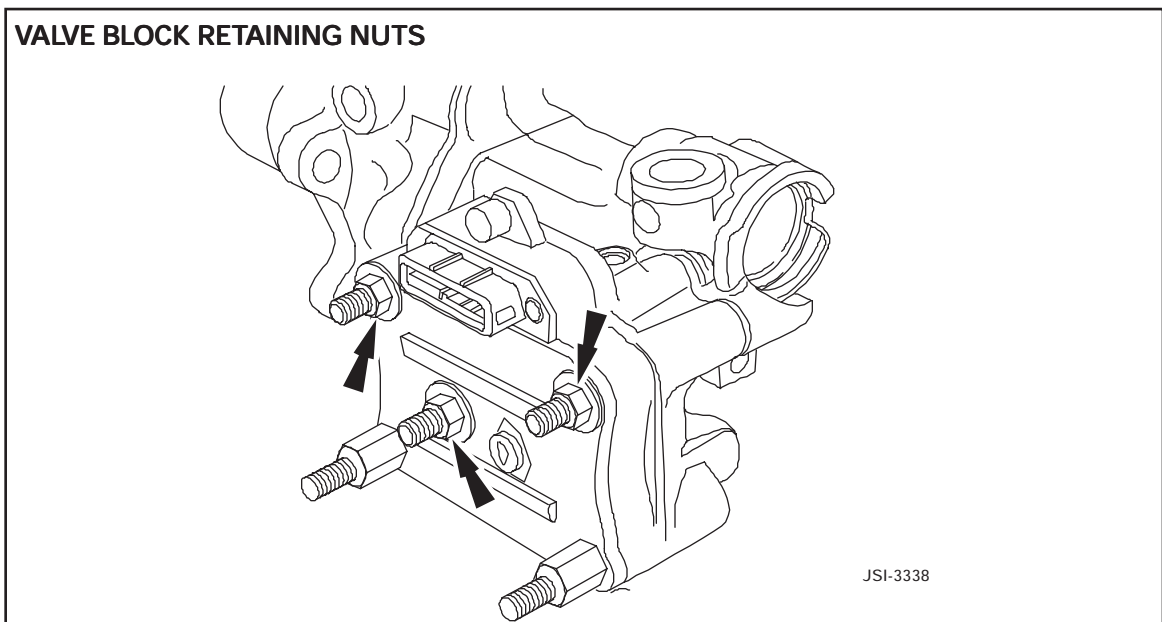

JSI-3338

ILLUSTRATION 1

4. Remove the 3 nuts (arrowed in Illustration 1) that retain the valve block to the

## O-RING LOCATIONS

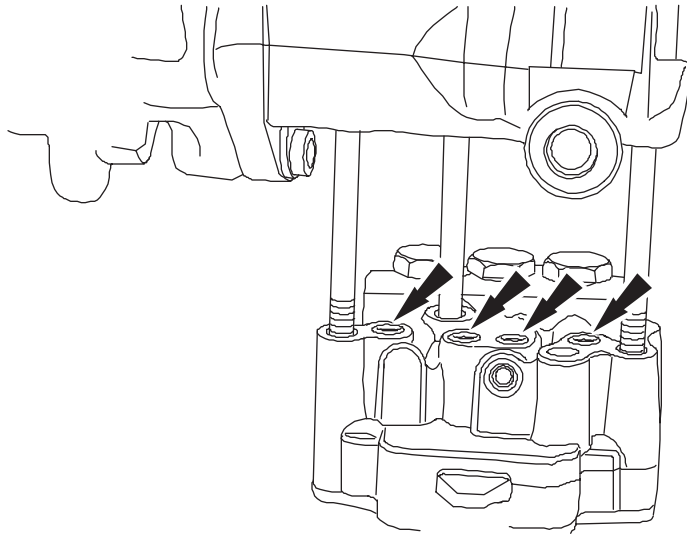

JSI-3339

ILLUSTRATION 2

actuator body to remove the valve block. Discard the 4 O-ring seals arrowed in Illustration 2.

5. Using a lint-free cloth, clean the faces of the actuator unit and the replacement valve block.
6. Lubricate the four (4) O-ring seals provided in the kit with brake fluid, and locate them in the four (4) recesses arrowed in Illustration 2.
7. Hold the actuator and valve block as illustrated, to keep the four (4) O-rings from shifting, and position the replacement valve block on the studs and push it into firm contact with the actuator unit.

Reinstall the center nut finger-tight, **after verifying that the O-rings are correctly located.**

8. Reinstall the remaining 2 nuts, and fully tighten all three to 25 Nm (18 lb.ft).
9. Reinstall the complete actuator assembly to the vehicle, as detailed in the appropriate Workshop Manual , Section 70, SRO 70-60-06, including refilling and bleeding the brake system.

**NOTE:** To prevent contamination of the valve block assembly in the future, clamp the brake line and open the bleeder valve when pushing the piston back during pad replacement.

**PARTS INFORMATION:**

<u>DESCRIPTION</u>	<u>PART NUMBER</u>	<u>QTY</u>
Valve block repair kit, Sedan 1990-94	JLM 11336	1
Valve block repair kit, XJS	JLM 11337	1

**WARRANTY INFORMATION:**

<u>FAULT CODE</u>	<u>R.O. NUMBER</u>	<u>DESCRIPTION</u>	<u>TIME ALLOWANCE</u>
HD DB **	70.60.2709	A.B.S. Valve block -replace SedanVIN 593884-667828	1.50 hrs.
		A.B.S. Valve block -replace SedanVIN 667829-708757	1.60 hrs.
		A.B.S. Valve block -replace XJSVIN up to 198334	1.35 hrs.