

TECHNICAL BULLETIN



Broken Door Flap Handle – Replace Handle Only

76-122

MODEL 1988-89 MY Sedan Range
VIN 506664-594575

DATE 8/96

ISSUE:

When servicing outside front door handles on 1988-89 MY Sedan Range vehicles, within the above VIN range, it is not necessary to replace the entire door handle assembly if the concern is a broken flap handle. The flap handle is available separately to allow a lower cost repair (Illustration 1).

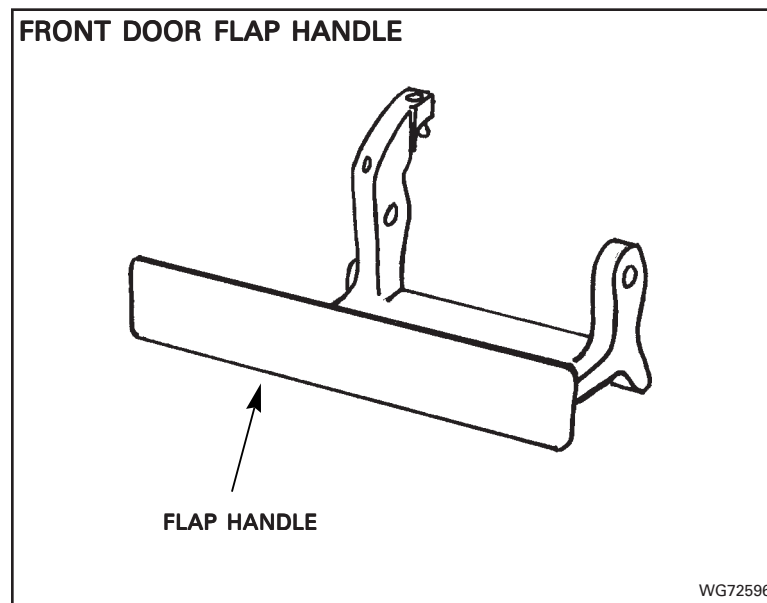

ILLUSTRATION 1

ACTION:

In case of a customer complaint of a broken flap handle on a 1988-89 MY Sedan Range vehicle, within the above VIN range, replace the flap handle as follows:

REPLACING FRONT DOOR FLAP HANDLE

1. Remove door handle assembly from vehicle. Refer to the XJ6 2.9-3.6 Service Manual, Volume 4, Section 76, operation 76.58.01.

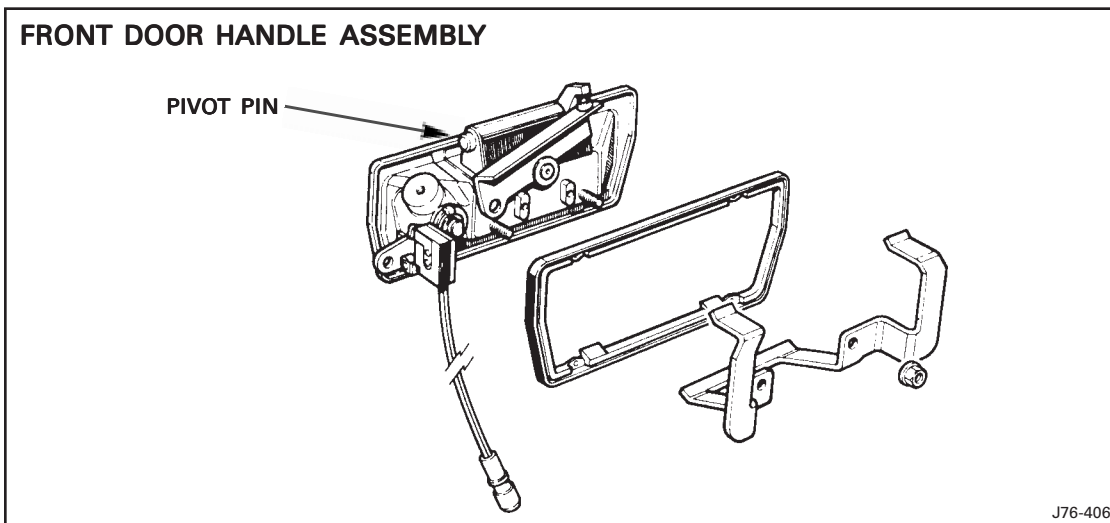

ILLUSTRATION 1

2. Pull back the rubber protective cover over the pivot pin (Illustration 2).
3. Remove one of the spring washers securing the pivot pin in the door handle assembly.
4. Remove the pivot pin and return spring.
5. Remove the rubber cover from the flap handle arm and then remove the flap handle.
6. Insert the new flap handle and place the rubber cover over the arm.
7. Insert the pivot pin with the return spring and secure the pin with the spring washer.
8. Position the protective cover over the pivot pin.
9. Reinstall door handle assembly.

PARTS INFORMATION:

<u>DESCRIPTION</u>	<u>PART NUMBER</u>	<u>QTY</u>
RH front flap handle kit	JLM 10772	1
LH front flap handle kit	JLM 10773	1