

TECHNICAL BULLETIN

 <p>JAGUAR SERVICE</p>	<p style="text-align: center;">Leak Detection System – Ultraviolet Dye</p> <p>MODEL 1993-94 MY Sedan Range DATE 10/98 1994-96 MY XJS with R134a</p>	<p style="text-align: center;">82-52</p>
--	---	---

ISSUE:

A UV-Fluorescent Leak Detection System, manufactured by Tracer Products, has been approved for use in the air conditioning systems of Jaguar Cars.

- The UV fluorescent dye, used in the leak detection system, was introduced into the air conditioning systems of 1998 MY vehicles to assist in the rapid and accurate diagnosis of refrigerant leaks.
- The dye can be added to the air conditioning systems of all vehicles with R-134a systems using the Tracer Products Universal Connector set.
- This dye is the only product recommended and approved for this purpose.
- The dye will remain in the system, within the lubricant, and has no effect upon the refrigerant. Additional dye does not cause a problem.
- This dye is visible when illuminated by a UV lamp, either directly or by wiping the suspected area with a cloth and then shining the UV lamp on that cloth.

ACTION:

When diagnosing refrigerant leaks, use the leak detection system consisting of:

- A UV fluorescent dye in a transparent tracer stick capsule.
- A Universal Connector Set which is used to add the fluorescent dye to the air conditioning system.
- An Ultraviolet Lamp to enable the operator to determine the source of any leak.

Note: An Ultraviolet Lamp is now mandatory workshop equipment and may be purchased locally or by contacting Tracer Products 1 (800) 641-1133 (USA) for a local distributor.

⚠ Warning: Always wear protective goggles when using a UV lamp. Do not direct the rays of the lamp at anyone.

PLACING DYE IN A/C SYSTEM

- The Universal Connect Set and Tracer Stick Capsule are used to introduce dye into the Air Conditioning systems of vehicles which were produced with systems charged with R134a, without the need to discharge the refrigerant.

Note: Two types of Universal Connect Set are available, 'Low Side Charging' and 'High Side Charging'. The 'High Side Charging' method is recommended: i.e. use Kit no. TP-9887.

- Evacuate or purge the Universal Connect Set hose assembly. Close all valves **finger tight**, do not apply force or damage may be caused to the valve seat.
- While holding the tracer stick capsule, (A, Illustration 1), vertically, so that the embossed arrow is pointing **upwards**, carefully remove the black screw cap and screw the capsule to the control valve, (B, Illustration 1), **finger tight**.
- Turn the control valve and capsule assembly so that the embossed arrow is now pointing **downwards**. Remove the second black screw cap from the capsule and screw the service valve fitting, (C, Illustration 1), to the capsule, **finger tight**.
- Connect the quick coupler, (D, Illustration 1), to the high side service port of the air-conditioning system.

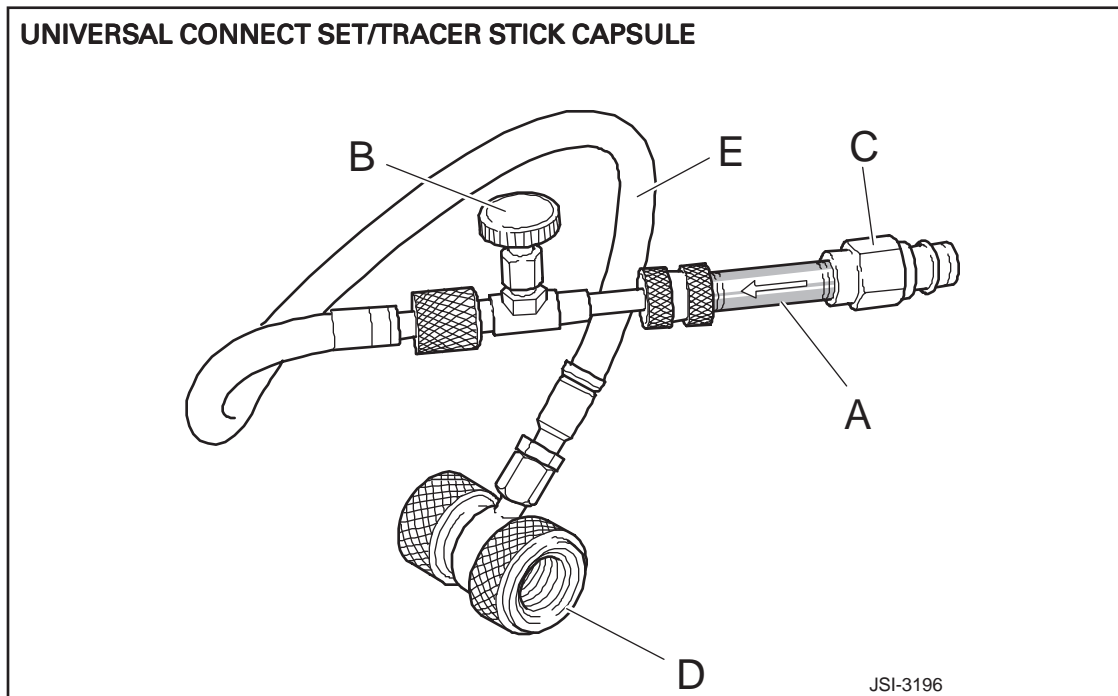

ILLUSTRATION 1

- Ensure that the control valve (B, Illustration 1) is closed.
- Connect the service valve fitting, (C, Illustration 1), to the high side quick coupler on the manifold or the recovery unit.

Note: Follow the recommended procedure of the refrigerant charging/recovery apparatus.

- Open the control valve, (B, Illustration 1), and the line to the charging/recovery apparatus to allow refrigerant to flow through the capsule, carrying the UV fluorescent dye into the system.
- After the dye has been flushed from the capsule, close the control valve and disconnect the connector set from the system and the charging/recovery apparatus.
- Remove the service valve fitting, (C, Illustration 1), from the capsule and retain it.
- Remove the capsule from the control valve, (B, Illustration 1), and discard it.
- Using suitable disposable, clean material and the water-based Glo-Away Fluorescent Dye Cleaner/Remover, wipe the service valve fitting and the control valve to remove surplus dye and so avoid handling contamination.
- Check, with a beam of ultraviolet light, that the dye has been removed.
- When the system has been filled, the label, (Illustration 2), must be fixed to the radiator crossmember, in the position shown.

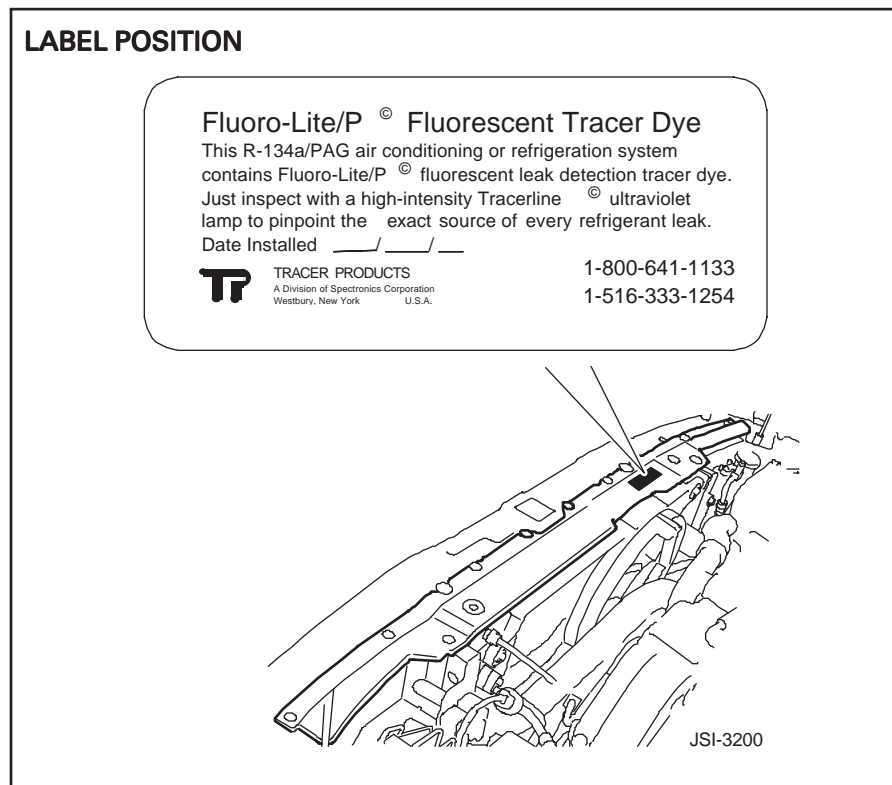

ILLUSTRATION 2

LEAK DETECTION

- Run the air conditioning system for 5 to 10 minutes to thoroughly distribute the dye throughout the system.
- Inspect the system by projecting a beam of Ultra-Violet light on to the system components, searching for a bright green glow which will indicate an escape of refrigerant carrying the dye.

- If the escape of refrigerant is not apparent, i.e. the escape is of a small amount, check the system 24 - 48 hours later, after the customer has operated the system as much as possible.
- After all the repairs are completed, thoroughly clean the areas where the dye was visible so that any remaining traces are not mistaken for a new leak.
- Recheck the area, with the Ultra-Violet light, to ensure no traces of dye are remaining.

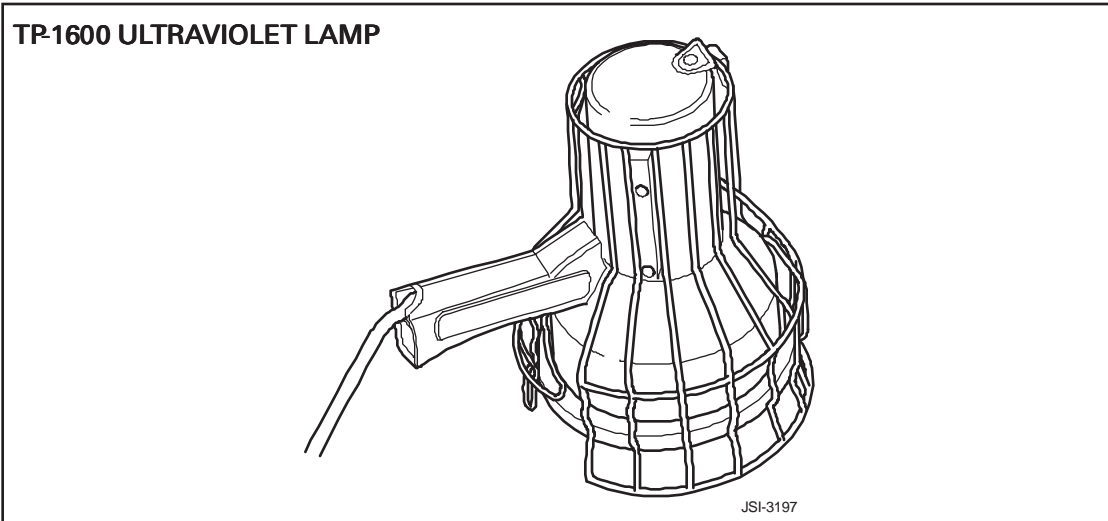

ILLUSTRATION 3

- When operating the TP-1600 110 VAC lamp (Illustration 3), 3 to 5 minutes must be allowed for warm-up.
- If the lamp is switched off, 10 to 15 minutes cool-down must be allowed before it is switched on again.
- The heat guard/stand allows the lamp to be left in the position illustrated, while the lamp is switched on, so that the beam is not directed at any person.
- TP-1600 UV bulb life is 5,000 hours.

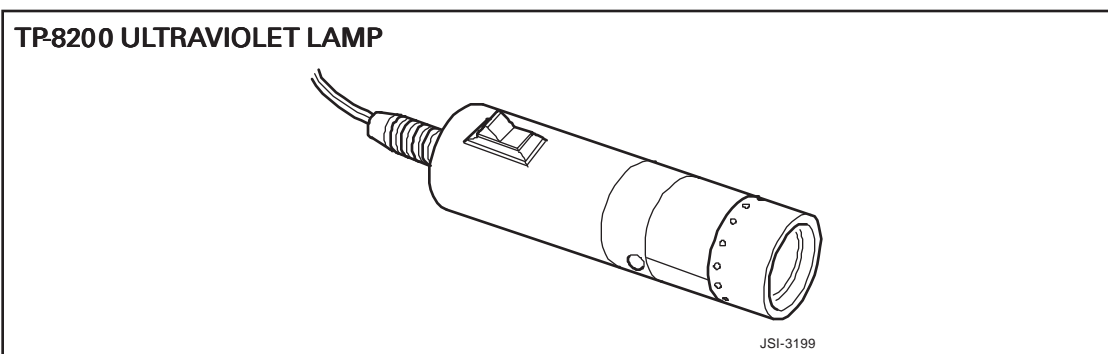

ILLUSTRATION 4

- When operating the TP-8200, (12 VDC, 50 Watts, 5 Amps, Illustration 4), UV lamp, for every 5 minutes of operation there must be a 15 minute, (switched off), cool down interval.
- Use only TP-1510 bulb as a replacement.

REFERENCE CHART

	Tracer-Stick Capsule Accessories
TP-3887	Low Side Charging Universal Connector Set for use with R-134A/PAG
TP-9887	High Side Charging Universal Connector Set for use with R-134A/PAG
	Tracer-Stick Capsule Kit
TP-3863	R-134A/PAG Systems, (Low Side Charging) 6 x TP-3860 capsules & TP-3887 universal connector set
TP-3864	R-134A/PAG Systems, (High Side Charging) 6 x TP-3860 capsules & TP-9887 universal connector set
	Tracer-Stick Capsules for Mobile A/C Systems
TP-3860-0601	R-134a/PAG Systems - 6 x 1.8 ml. (0.06 oz.) capsules for systems with up to 1.3 Kg. (2.9 lb.) of refrigerant
	Tracerline UV Lamp Kit
TP-1620	TP-1600 lamp, (110 VAC), TP-9940 spectacles, TP-1640 Carry case
TP-8220	TP-8200 TITAN lamp, (12 VDC 50 W), UV enhancing spectacles, Carry case
TP-8020	TP-8000 TITAN lamp, (12 VDC 100W), UV enhancing spectacles, Carry case
	Tracerline Replacement Parts
TP-1050	UV lens filter for TP-1600 lamp
TP-8211	UV lens filter for TP-8200 lamp
TP-8011	UV lens filter for TP-8000 lamp
TP-1510-0003	12 V 50 W bulb for TP-8000 lamp 12 V 50 W bulb for TP-8200 lamp 12 V 50 W bulb for TP-1700A lamp
TP-1610	115 V 150 W bulb for TP-1600 lamp
TP-1660A	Heat guard lamp stand for TP-1600 lamp

REFERENCE CHART

	Tracerline UV Lamps
TP-8200	TITAN, (12 VDC), UV/Blue lamp, 50 W 'instant on' bulb, 4.25m. (14') cable, UV absorbing spectacles
TP-8000	TITAN, (12 VDC), UV/Blue lamp, 100 W 'instant on' bulb, 4.25m. (14') cable, UV absorbing spectacles
TP-1600	Super high intensity UV lamp, (110VAC), 150 W self ballasted bulb, 2.5m. (8') cable, Heat guard lamp stand, TP-9940 UV absorbing spectacles
TP-1600R/F	Super high intensity UV lamp, (110VAC), 150 W self ballasted bulb, 9.0m. (30') retractable cable, Heat guard lamp stand, TP-9940 UV absorbing spectacles
	Tracerline Accessories
TP-1640	Plastic carrying/storage case for TP 1600 lamp
TP-1740	Plastic carrying/storage case for TP 800 & TP 8200 lamps
TP-9940	UV absorbing spectacles
	Glo-Away Fluorescent Dye Cleaner/Remover
TP-9000-0008	1 x 240 ml, (8 oz) bottle with spray nozzle
TP-9000-0016	1 x 480 ml, (16 oz) refill bottle
TP-9000-1208	12 x 240 ml, (8 oz) bottle with spray nozzle
TP-9000-1216	12 x 480 ml, (16 oz) refill bottle

Supplier to call for local distributor:

TRACER PRODUCTS
 956 Brush Hollow Road, P. O. Box 483
 Westbury, NY 11590
 1 (800) 641-1133