

TECHNICAL BULLETIN



Compact Disc Changer – LXF 4160CA – 1993-94 MY Sedan Range Installation Instructions

86-176

MODEL Sedan Range 1993-94 MY

DATE 9/96

VIN 667829 - 708757

ISSUE:

A unique bracket has been developed to allow the installation of third generation (1995-96 MY Sedan Range) CD autochangers (part no. LXF 4160CA) in the 1993-94 MY Sedan Range vehicles.

The instructions have been written specifically for 1993-94 MY Sedan Range vehicles and must not be used for installing the autochanger in any other vehicle.

ACTION:

PRE-INSTALLATION REQUIREMENTS

1. Remove the battery cover and spare tire assembly.
2. Loosen and lower the top of the luggage compartment forward liner to gain access to the fuel tank area.

INSTALLING THE CD AUTOCHANGER

1. Route the data cable over the luggage compartment forward liner, then reposition and fully seat the liner; ensuring that the data cable is positioned so it cannot be trapped by the trunk lid hinge.
2. Remove the three transit screws (Illustration 1) from the base of the autochanger unit and install them in the three storage holes provided on the

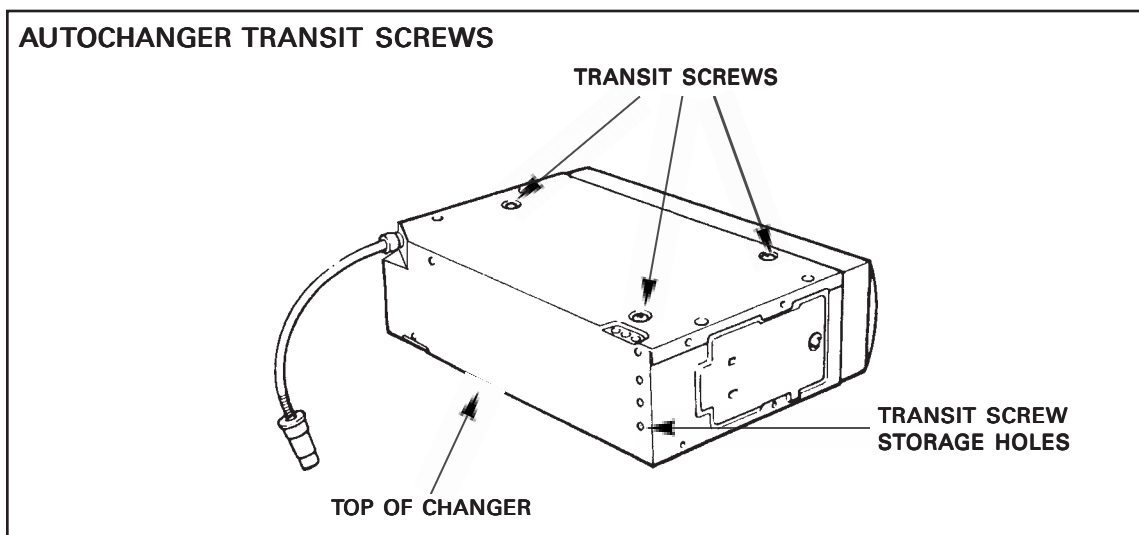

ILLUSTRATION 1

back of the autochanger to prevent their loss.

3. Using the screws provided, attach the bracket to the left and right hand mounting screw holes on the autochanger unit, then **fully** tighten the securing screws.
4. Remove the protective cap from the data cable, then connect the data cable to the flylead on the CD autochanger.
5. Place the assembled unit against the underside of the upper panel, aligning the holes in the mounting brackets with those in the upper panel. Install the four securing bolts, then **fully** tighten the bolts to secure the unit to the vehicle.
6. Position any left over data cable behind the luggage compartment forward liner.
7. Reinstall the spare tire assembly, and the battery cover.
8. Check the CD autochanger unit for the correct operation; refer to the detailed information in the Sound System Handbook supplied in the Driver's Literature Pack.

KIT CONTENTS

	QTY.
Mounting bracket	1
Mounting bracket to body bolts	4
Mounting bracket to CD autochanger screws	4

PARTS INFORMATION:

<u>DESCRIPTION</u>	<u>PART NUMBER</u>	<u>QTY</u>
CD autochanger mounting bracket	JAG 523	1
CD autochanger	LXF 4160CA	1