

Special Tool 204-225 –
Front Suspension Subframe Rear Bushing –
Removal & Installation

MODEL 1998 MY-ON
V8 XJ Series

VIN 812256-ON

Issue:

A mandatory Service Tool 204-225, (items 2 and 3, Illustration 1) was introduced to remove and install the rear bushings of the front suspension subframe. Item 1, Illustration 1, is the existing tool 204-116 (JD 143). The bush is retained in the housing by an interference fit, and can only be removed and installed with the use of a hydraulic press.

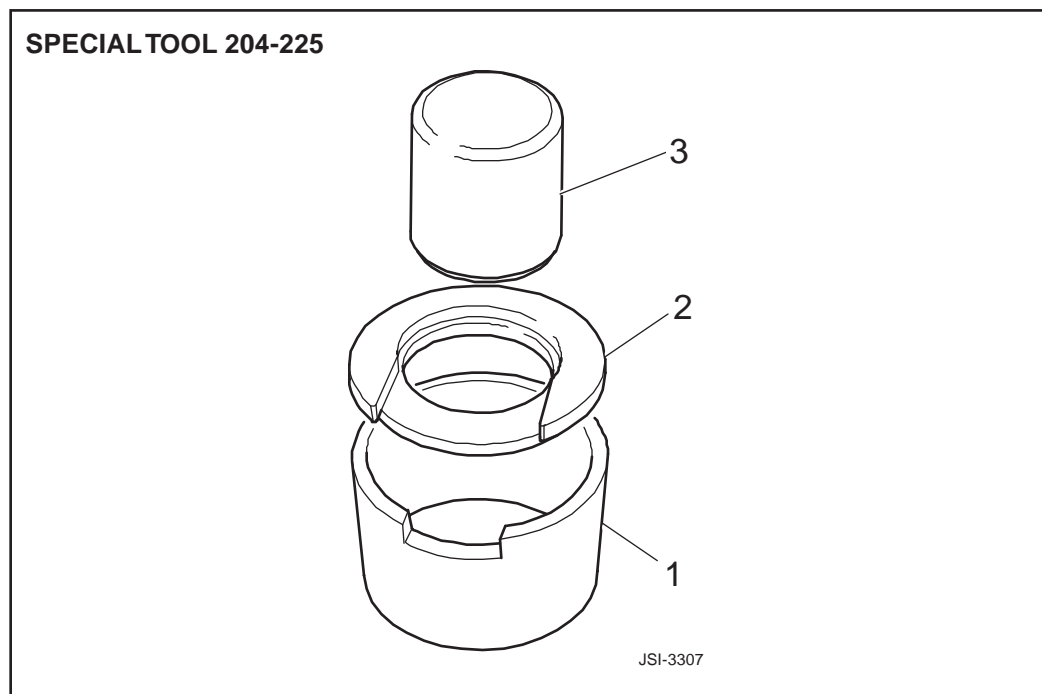

ILLUSTRATION 1

Action:

REMOVAL OF REAR BUSHING FROM SUBFRAME:

1. Position item 1, Illustration 1 of the tool, onto the bed of the press.
2. Seat item 2, Illustration 1, with its recess facing up, into the top of item 1.
3. Seat the bush housing and subframe into the recess of item 2.
4. Position item 3, Illustration 1 on top of the bush, so that the circumference of the tool aligns with the circumference of the bush.

5. Align the tool with the press ram, and press the bush from the housing (Illustration 2).

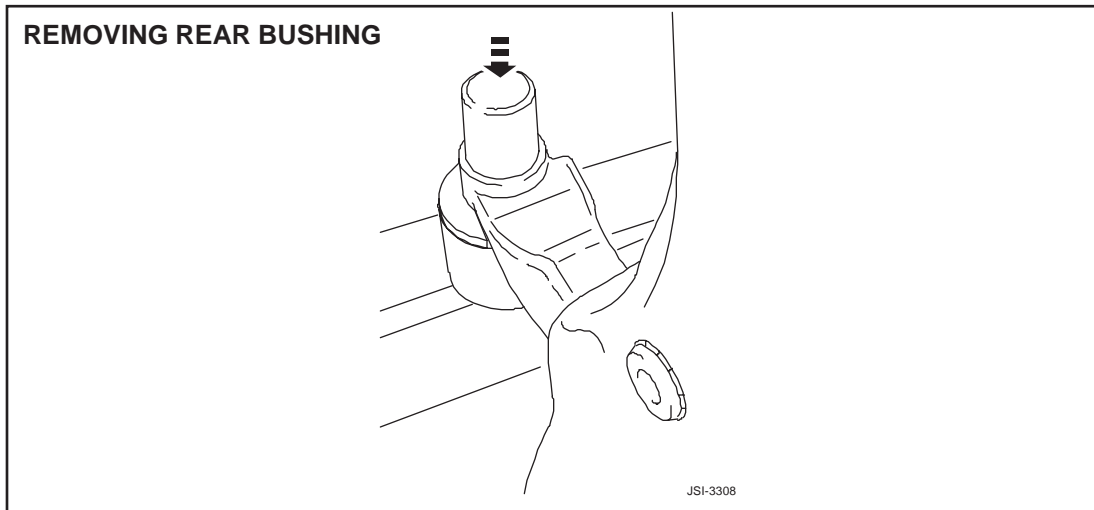

ILLUSTRATION 2

INSTALLATION OF REAR BUSHING FROM SUBFRAME:

1. Scribe a reference mark on the outer diameter of the bush (B, Illustration 3), in-line with the bush's location tang (A).
2. Align the reference mark on the bush, with the indent (C, Illustration 3) on the bush housing.
3. Seat item (3, Illustration 3) of the tool on top of the bush, and partially press the bush into the housing.
4. Make sure that the bush reference mark and the bush housing indent are aligned.
5. Assemble the bush replacement tool, as described in the removal item, and press the new bush into position.

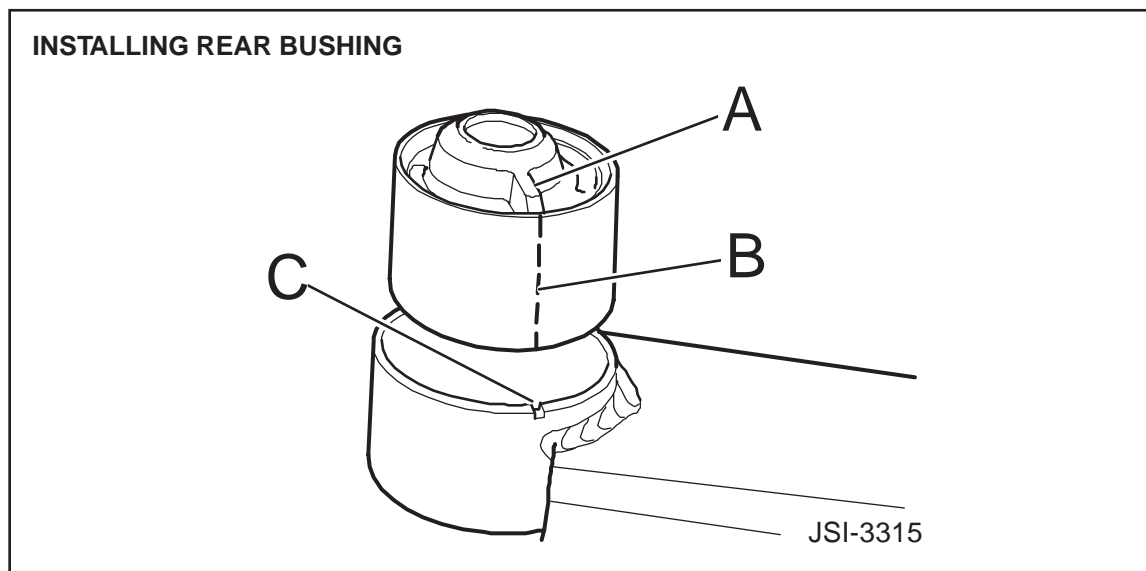

ILLUSTRATION 3