

**Rear Suspension Hub Carrier Fulcrum Bolts –
Revised Specification –
Replace – Service Action S468****MODEL**1998 MY XK8 Range
1998 MY V8 XJ Series**VIN**025588-026519
837386-840302**Issue:**

Some 1998 MY vehicles within the above VIN ranges may have outer fulcrum bolts of the incorrect specification in the rear suspension. The fulcrum bolts connect the rear hub carriers to the outer ends of the rear suspension wishbones.

Action:

Install replacement fulcrum bolts on all 1998 MY vehicles within the above VIN ranges. If possible perform this action while the vehicle is undergoing PDI or prior to delivery to the customer. In the case of vehicles already in service, perform the action at the first service opportunity or next dealer visit.

FULCRUM BOLT REPLACEMENT PROCEDURE

1. Raise the vehicle on a lift so that the rear suspension arms are supported while still allowing access to the nut (Illustration 1) and also to the head of the fulcrum bolt (Illustration 2).

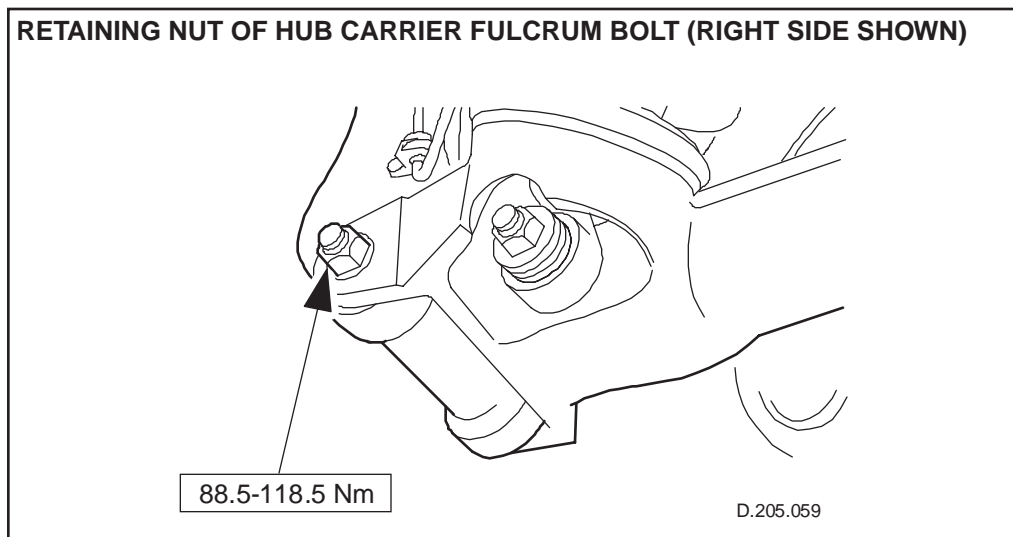

ILLUSTRATION 1

2. Remove the rear road wheels.
3. If necessary, clean the head of each fulcrum bolt so as to be able to identify the marker line stamped on the head of each bolt (Illustration 2). Use a fine-pointed scribe to mark on each wishbone the location of the marker line, prior to dismantling. The marker line will not necessarily be in the location illustrated, depending on previous adjustment to effect correct wheel alignment.

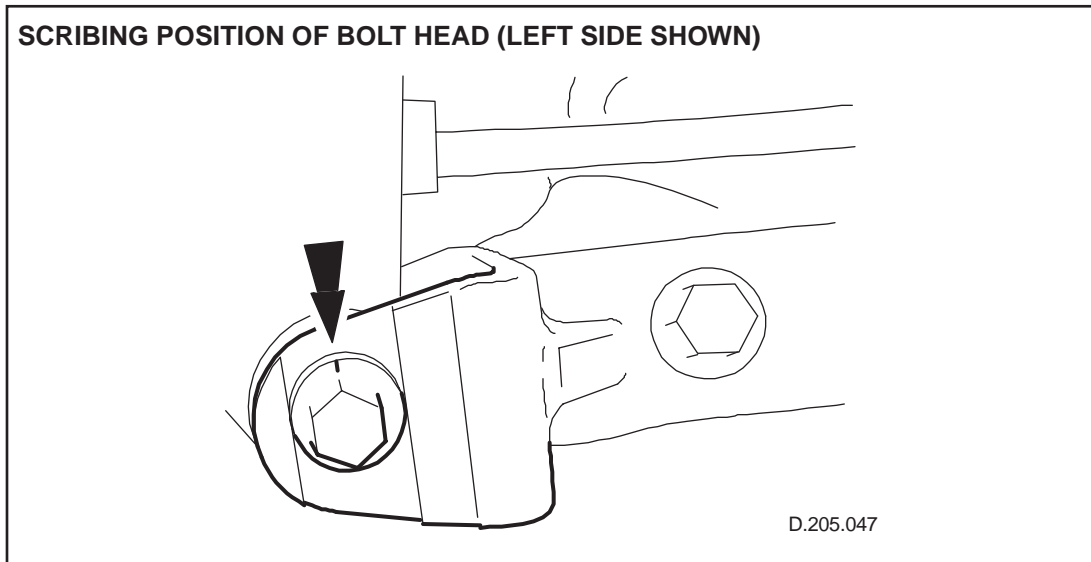

ILLUSTRATION 2

4. Remove the retaining nut from the fulcrum bolt on one side of the vehicle and retain the washer for reuse.
5. Supporting the hub carrier in position and use a short drift approximately 14 mm. in diameter to drive out the fulcrum bolt toward the rear. Discard the bolt and nut.
6. While still supporting the hub carrier in position, install the replacement bolt from the rear. Rotate the bolt as necessary to allow the eccentric head of the bolt to fully seat in the guide slot in the wishbone. Align the marker line on the head of the bolt with the line previously scribed on the wishbone in step 3. Install the washer with a **new** self-locking nut, and tighten until the bolt begins to grip, ensuring that the marker line on the bolt head remains aligned to the scribed line.
7. Repeat 5 & 6 above on the opposite side of the vehicle.
8. Reinstall the wheels and lower the rear of the vehicle to the lift platform or workshop floor, as appropriate for the following operations. Check that the road wheel nuts are fully tightened.
9. Check the level of fuel in the tank. If full, no adjustment is required. If partly full, place in the luggage compartment, as near to the fuel tank as possible, weights equivalent to the amount of fuel which would be required to fill the tank to full condition. Allow 8 lbs. for each gallon which would be required to bring the tank to full. Allow 0.8 kg for each liter of fuel. Any luggage in the luggage compartment or in the passenger compartment should temporarily be removed, so that the vehicle is at the specified weight condition for a rear wheel alignment check.

10. Jounce the vehicle at both front and rear (i.e. push down and then release the bumper covers) to ensure that the suspension settles at its normal ride height.
11. With the rear tires standing on turntables, apply wheel alignment equipment to the vehicle. Check that the rear camber and toe measurements are within the figures in the table below. If necessary, rotate the fulcrum bolt so that its eccentric head adjusts the position of the lower end of the hub carrier to obtain readings within the stated limits. After completing the adjustment, tighten the fulcrum bolt retaining nut to 103 +/- 15.5 Nm (76 +/- 11.4 lb. ft.), ensuring that the position of the bolt head is not moved.
12. After final tightening, apply a spot of bright yellow/orange oil-based paint to the head of each bolt. This will identify that the bolt has been replaced during this service action.
13. Remove any weights previously placed in the luggage compartment. Replace any luggage which had been temporarily removed.

REAR SUSPENSION ALIGNMENT DATA

Model	Total Toe	Camber
V8 XJ Series	0.23° Toe In +/- 0.33°	0° to - 1.2°
XK8	0.3° Toe In +/- 0.2°	- 0.1° to - 0.9°

FRONT SUSPENSION ALIGNMENT DATA

Model	Total Toe	Camber	Caster
V8 XJ Series	0.25° Toe In +/- 0.15°	0° to - 1.2°	+ 4.0° to 8.0°
XK8	0.2° Toe In +/- 0.2°	+ 0.3° to - 0.9°	+ 5.0° to 8.0°

Parts Information:

<u>DESCRIPTION</u>	<u>PART NUMBER</u>	<u>QTY</u>
Pivot bolt - S468	JZB 100047/K	2
Lock nut - S468	JNV 114041/K	2

Note: All stock of fulcrum bolts Part No. JZB 100047 supplied by or currently held by Jaguar Parts Operations is of the correct specification. The above part numbers are **specifically** for use with **this Service Action only** and may not be used in connection with any other Customer or Warranty repair.

Warranty Information:

Service Action S468

<u>VEHICLE</u>	<u>SUMMARY CODE</u>	<u>R.O. NUMBER</u>	<u>DESCRIPTION</u>	<u>TIME ALLOWANCE</u>
V8 XJ Series	NL	64.91.08	Replace fulcrum bolts & set toe	1.15 hrs.
1998 MY		10.10.10	Drive in/drive out	0.15 hrs.
VIN 837386-840302				
Model codes 2811, 2851, 2853, 2914, and 2953				
XK8				
1998 MY				
VIN 025588-026519				

NOTE: Always perform a DCS claim search first to determine whether this service action has been performed on this vehicle. The warranty selection under the vehicle inquiry will give a listing of all claims against the vehicle. If S468 appears in the fault code field, do not perform this service action.

CLAIM SUBMISSION PROCEDURE:

Warranty summary codes have been assigned to this service action in order to simplify claim submission. The dealership will be reimbursed the parts and labor time allowance as indicated.

DCS DEALERS

Submit claims using the appropriate summary code for the vehicle model and work performed. Follow standard campaign submission procedures.

NON-DCS DEALERS

Submit claims on the Recall Campaign Summary form W-25. Enter the appropriate summary code for the vehicle model and work performed in the Repair Code column. Do not use the W-1 warranty claim form.