

New Special Tool 206-066A – ABS Rotor Nut Socket (Version 2)

MODEL
 1997 MY-ON XK8 Range
 1998 MY-ON V8 XJ Series
 VIN
 001001-ON
 812256-ON

Issue:

Introduction of mandatory Service Tool: 206-066A.

Caution: The ABS rotor nut socket 206-066 which precedes the above socket must not be used for torque settings which exceed 190 Nm.

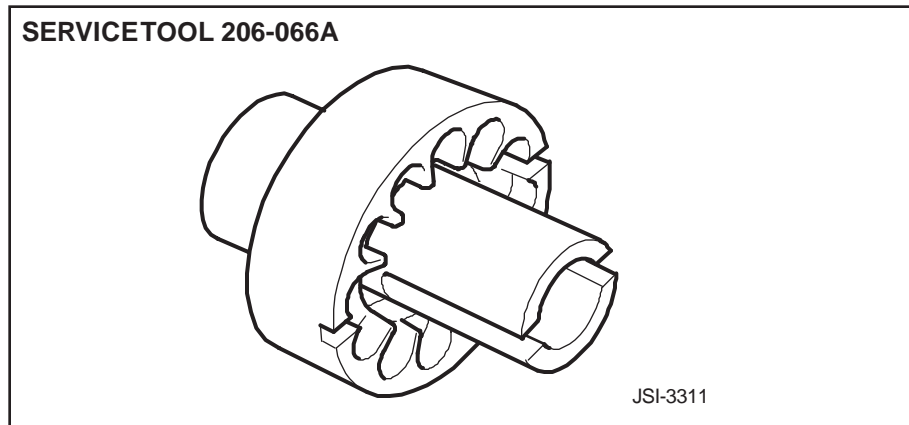

ILLUSTRATION 1

Action:

REMOVAL:

1. Secure the hub in a vice using hub holding tool 204-195.
2. Remove the rotor-nut spring clip, by squeezing the two legs together until the prongs are released from the hub retaining holes.
3. Discard the spring clip.
4. Using the rotor-nut socket, remove the rotor-nut.

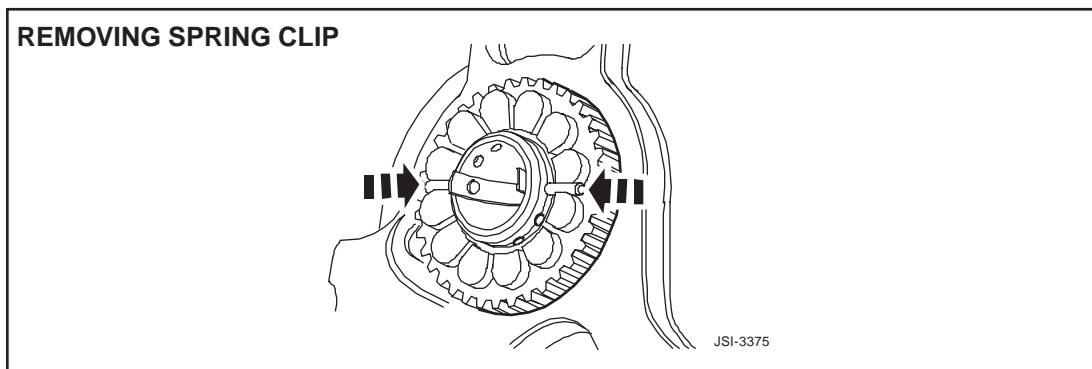

ILLUSTRATION 2

TIGHTENING ROTOR NUT

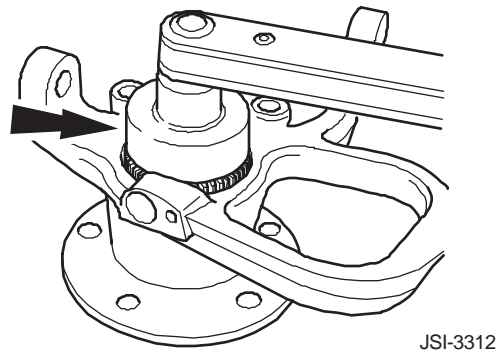

ILLUSTRATION 3

INSTALLATION

1. Fit the rotor-nut to the hub.
2. Tighten the rotor-nut to 270-330 Nm.
3. Install a new rotor-nut spring clip into the hub retaining holes and, if aligned, into the castellated slots of the rotor-nut.
4. It may be necessary to tighten the rotor-nut further, to engage the spring clip into the castellated slots of the rotor-nut.

Warning: Do not slacken the rotor-nut to engage the spring clip.

5. Remove the hub from the vice.