

**Crankshaft Main Bearing &
Connecting Rod Tools****MODEL**1997 MY-ON XK8 Range
1998 MY-ON V8 XJ Series**VIN**001001-ON
812256-ON**Issue:**

303 534 (JD.220), dummy main bearing caps & bolts, (supplied in sets of 5 caps and 10 bolts), and 303 535 (JD.221) bore protectors, (supplied as a pair), were introduced.

Action:

Both the bearing caps (Illustration 1) and the bore protectors (Illustration 2) are made of a plastic material which cannot harm bearing and bore surfaces.

303 534 (JD.220), DUMMY MAIN BEARING CAPS & BOLTS

ILLUSTRATION 1

The bearing cap and bolts are designed to act as a substitute main bearing cap assembly during the assembly of the engine and must be installed without the lower shell bearing; the upper shell will be retained in place by the cap.

303 535 (JD.221) BORE PROTECTORS

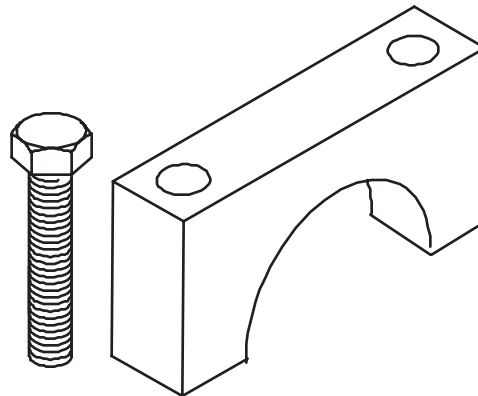
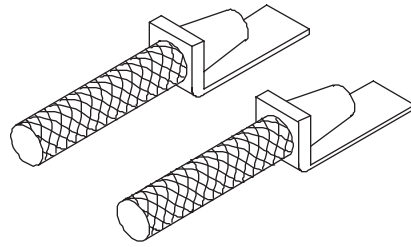

ILLUSTRATION 2

The connecting rod and cap are not manufactured as previously but are fractured across the bearing diameter to provide a split bearing.

As a result of the fracturing of the connecting rod material the edge of the rod is coarse and could damage the cylinder face when the assembled piston and connecting rod are introduced into the bore.

303 535 bore protectors are plugs which fit in the connecting rod bolt drillings. The flap attached to the plug is designed to mask the fractured edge from the cylinder bore.