



XK

DATE 06/04

303-S845

SERVICE

TECHNICAL BULLETIN

Corroded Filter Vent Pipe –
Canister Close Valve –
Service Action S845

MODEL 2001-03 MY
XK Range

VIN A13961-A33149

Issue:

On a number of XK vehicles within the above VIN ranges, the canister close valve (CCV) to filter vapor pipe has been internally corroding. This condition can cause rust particles to flow in to the CCV.

Action:

Replace the filter vapor pipe with the latest specification vapor pipe at the next available opportunity.

CONVERTIBLE VEHICLES ONLY

Note: Some vehicles may have had the vapor pipe filter relocated and the vapor pipe replaced as part of Technical Service Bulletin: 303-61. Check the location of the vapor pipe filter, if it has been relocated to the outside of the suspension turret, this Service Action does not apply to that vehicle.

To replace the vapor pipe, follow the workshop procedure below:

WORKSHOP PROCEDURE

Note: If the vapor pipe filter has been relocated to the outside of the suspension turret, no further action is required.

NOTE: The information in Technical Bulletins is intended for use by trained, professional technicians with the knowledge, tools, and equipment to do the job properly and safely. It informs these technicians of conditions that may occur on some vehicles, or provides information that could assist in proper vehicle service. The procedures should not be performed by "do-it-yourselfers." Do not assume that a condition described affects your car. Contact a Jaguar retailer to determine whether the Bulletin applies to your vehicle.

Workshop Procedure

Note: If the vapor pipe filter has been relocated to the outside of the suspension turret, no further action is required.

All vehicles

1. Raise vehicle on lift.
2. Disconnect vapor pipe hose from filter (Illustration 1).

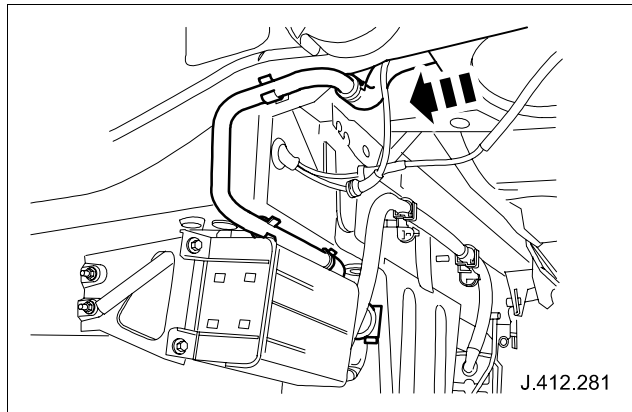

Illustration 1

3. Displace vapor pipe from plastic body clips (Illustration 2).

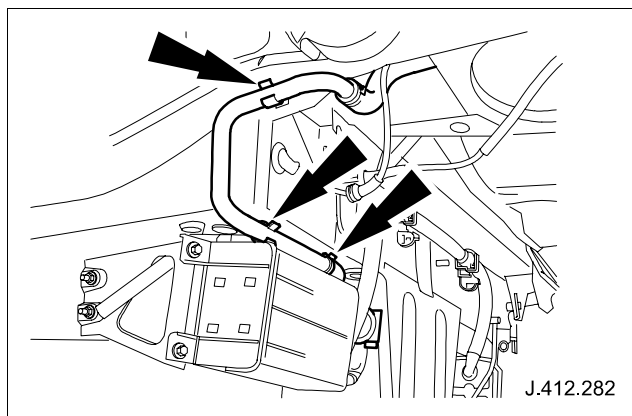

Illustration 2

4. Reposition canister close valve connector rubber cover for access (Illustration 3).

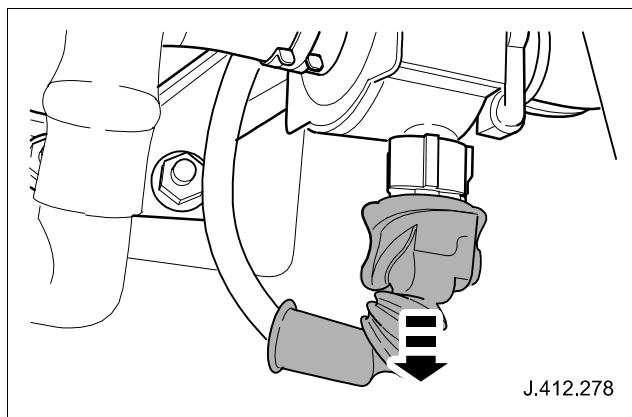

Illustration 3

5. Disconnect canister close valve connector (Illustration 4).

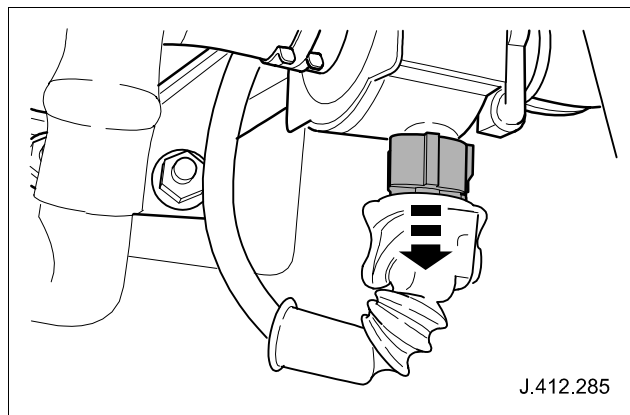

Illustration 4

Convertible vehicles only

6. Release and reposition canister close valve to carbon canister hose securing clip (Illustration 5).

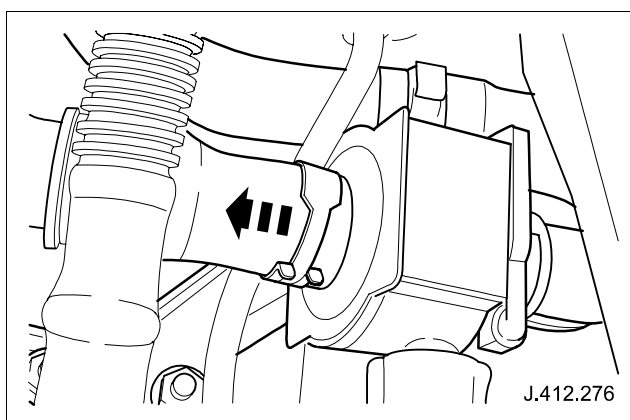

Illustration 5

7. Undo and remove canister close valve to body securing nut (Illustration 6).

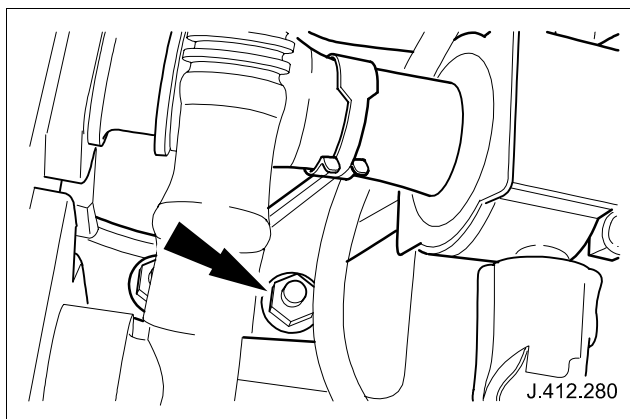

Illustration 6

8. Remove carbon canister to body securing nut (adjacent to canister inlet/outlet pipes, Illustration 7).

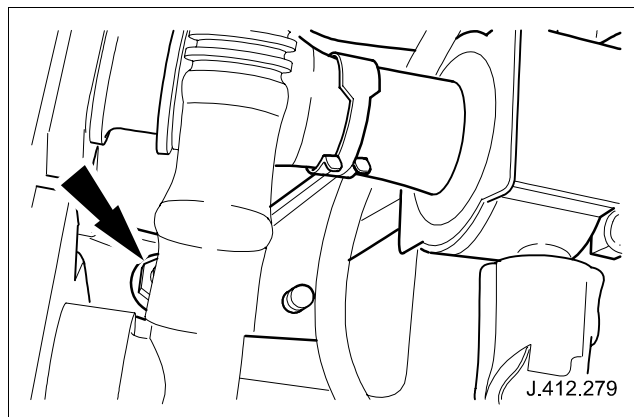

Illustration 7

9. Displace and reposition canister close valve and carbon canister from body studs for access.
10. Disconnect canister close valve from carbon canister hose.
11. Remove canister close valve/vapor pipe assembly from vehicle (Illustration 8).

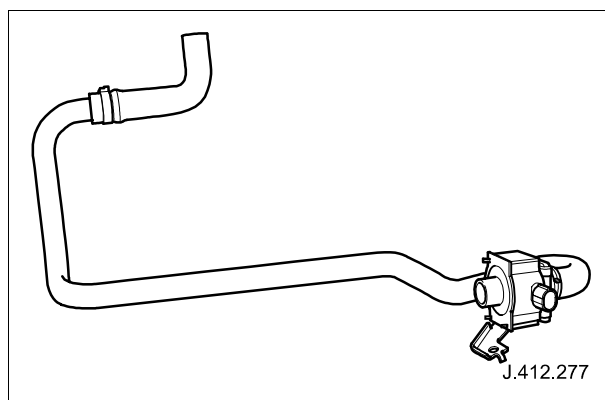

Illustration 8

All vehicles

12. Release and reposition vapor pipe hose to canister close valve securing clip.

Note: Illustration 9 shows the canister close valve removed from the vehicle. When carrying out this step on coupe vehicles the canister close valve will still be installed in the vehicle.

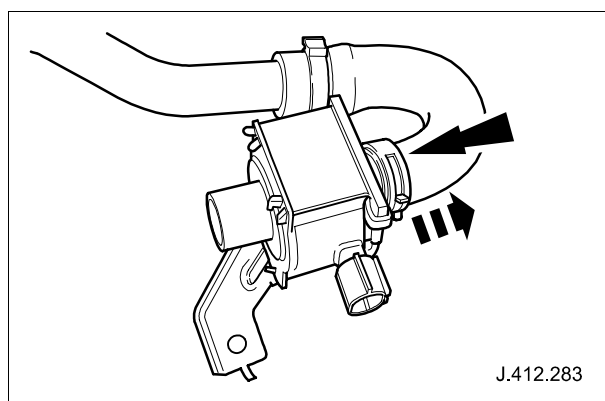

Illustration 9

13. Remove the vapor pipe hose from the canister close valve and place aside.

Note: Illustration 10 shows the canister close valve removed from the vehicle. When carrying out this step on coupe vehicles the canister close valve will still be installed in the vehicle.

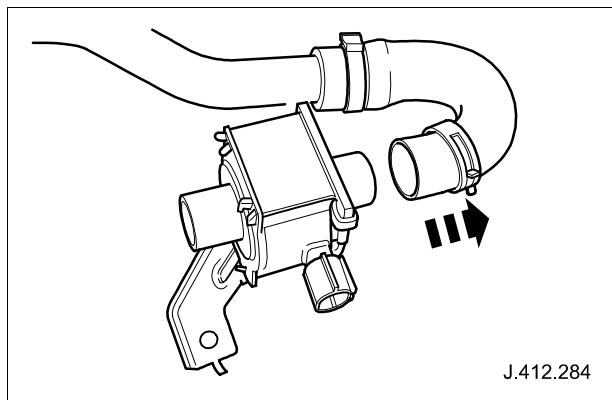

Illustration 10

14. Remove securing clip from vapor pipe hose.
15. Place vapor pipe hose assembly aside.
16. Place new vapor pipe/hose assembly to front.
17. Install securing clip to vapor pipe hose.
18. Install the vapor pipe hose to the canister close valve.
19. Reposition vapor pipe hose to canister close valve-securing clip.

Convertible vehicles only

20. Install canister close valve/vapor pipe assembly to vehicle.
21. Connect canister close valve to carbon canister hose.
22. Reposition carbon canister and canister close valve to body studs, ensuring that the canister close valve bracket alignment tang engages body hole.
23. Install and tighten carbon canister to body securing nut.
24. Install and tighten canister close valve to body securing nut.
25. Reposition canister close valve to carbon canister hose securing clip.

All vehicles

26. Connect canister close valve connector.
27. Reposition canister close valve connector rubber cover.
28. Secure vapor pipe to plastic body clips.
29. Connect vapor pipe hose to filter.
30. Lower vehicle.

Caution: It should be noted that all displaced oils and fluids should be disposed of locally, ensuring compliance with local authority legislation and health and safety guidelines.

Parts Information:

DESCRIPTION
NJC 6107EA

PART NUMBER
Pipe Assembly

QTY
1

Warranty Information:

Warranty claims should be submitted quoting program code S845 together with the relevant option code found in table below. This will result in payment of the stated time and where applicable parts/miscellaneous expense codes.

The options that allow for drive in/drive out can only be claimed when the vehicle has been brought in to the workshop for this action alone to be undertaken.

The SROs and parts items listed in the table have been included for information only; there will be no requirement to enter the parts or SROs onto the claim.

Service Action S845

Model	Year	VIN Range
XK8	2001 MY	1N A13961 - 1N A22928
XKR	2001 MY	1P A13961 - 1P A22928
XK8	2002 MY	1N A22929 - 1N A30344
XKR	2002 MY	1P A22929 - 1P A30344
XK8	2003 MY	12 A30345 - 12 A33149
XKR	2003 MY	13 A30645 - 13 A33149

Program Code	Option	Description	SRO	Time	Part Number	Part Description	Qty
All models							
S845	A	Check location of vapor pipe filter – no further action required.	10.10.99	0.2	-	-	-
S845	K	Check location of vapor pipe filter – no further action required.	10.10.99	0.2	-	-	-
		Drive in/Drive out	10.10.10	0.1 hrs.			
Coupe							
S845	B	Replace pipe – coupe.	17.91.39	0.2	NJC 6107EA	Pipe Assembly	1
S845	C	Replace pipe – coupe.	17.91.39	0.2	NJC 6107EA	Pipe Assembly	1
		Drive in/Drive out	10.10.10	0.1 hrs.			
Conv.							
S845	D	Check location of vapor pipe filter, replace pipe – convertible.	17.91.39/70	0.2	NJC 6107EA	Pipe Assembly	1
S845	E	Check location of vapor pipe filter, replace pipe – convertible.	17.91.39/70	0.2	NJC 6107EA	Pipe Assembly	1
		Drive in/Drive out	10.10.10	0.1 hrs.			

Note: Always perform a DDW claim search first to determine whether this service action has been performed on this vehicle. The “Review Claim History” function will provide a listing of all claims against the vehicle. If this service action number appears in the program code field, do not perform this service action.