



Sedan Range

DATE 7/95

03.1-04

SERVICE

TECHNICAL BULLETIN

Poor Idle Quality –
Normally Aspirated AJ16 Engine –
Valve Timing Modification

MODEL 1995 MY
4.0L NA
VIN
See engine no. below

ISSUE:

To improve idle quality, revised camshafts with reduced valve timing overlap were introduced on the normally aspirated engines as running change 95/13. The original camshafts, with a maximum opening position of 110 degrees have been superseded by camshafts with a maximum opening position of 114 degrees. This change is accomplished by machining the camshaft slot in a different position. The valve timing overlap is reduced from 22 degrees on the 110 camshafts to 14 degrees on the 114 camshafts. The maximum opening position of the 114 intake camshaft is 114 degrees after top dead center (ATDC) while the maximum opening position of the exhaust camshaft is 114 degrees before top dead center (BTDC). Normally aspirated engines with the 110 camshafts, that exhibit poor idle quality, can be modified to achieve the same reduction in valve timing overlap as with the 114 camshafts.

NOTE: Refer to Illustration 5, to identify engines with 110 camshafts that have already been modified.

The 114 camshafts were introduced for a period, withdrawn, and then re-introduced as a permanent change. The following table lists the change points by engine number:

<u>Model</u>	<u>Introduction of the 114 camshafts</u>	<u>Re-introduction of the 110 camshafts</u>	<u>Re-introduction of the 114 camshafts</u>
Sedan 4.0L	9JPFRB129204	9JPFRB130241	9JPFNB133653



ACTION:

In case of a customer complaint of poor idle quality on a vehicle equipped with the 110 camshafts only, first check for punch marks on the timing cover near the camshaft position sensor, Illustration 5, to determine if the timing modification has already been performed. If not, reset the camshaft timing and spark plug gap as described below.

In addition, on engines with numbers below 9J103935, modify the bolts retaining the upper chain damper to the upper damper saddle as described at the appropriate point in the procedure.

VALVE TIMING MODIFICATION PROCEDURE

1. Disconnect the battery negative cable.
2. Remove the coil cover and the on-plug coils. Discard the seal and gaskets.
3. Remove the camshaft cover and discard the seal. Remove all six spark plugs.
4. Check the tappet clearances with the engine at room temperature. If necessary, adjust any that are not within the specifications of 0.012 - 0.014 inch (0.30 - 0.36 mm). Refer to section 12.29.48 of the AJ16 Engine Service Manual.
5. Turn the crankshaft until the No. 1 cylinder is at Top Dead Center (TDC) on the compression stroke, i.e. with the cam lobes on the No. 1 cylinder pointing upwards as in Illustration 1. This position can be checked by temporarily inserting the camshaft setting tool 18G-1433/A into the slot on each camshaft.
6. On engines with numbers below 9L103934 (XJS Range) or 9J103935 (Sedan Range) only, remove the upper chain damper and saddle assembly and set aside for modification.

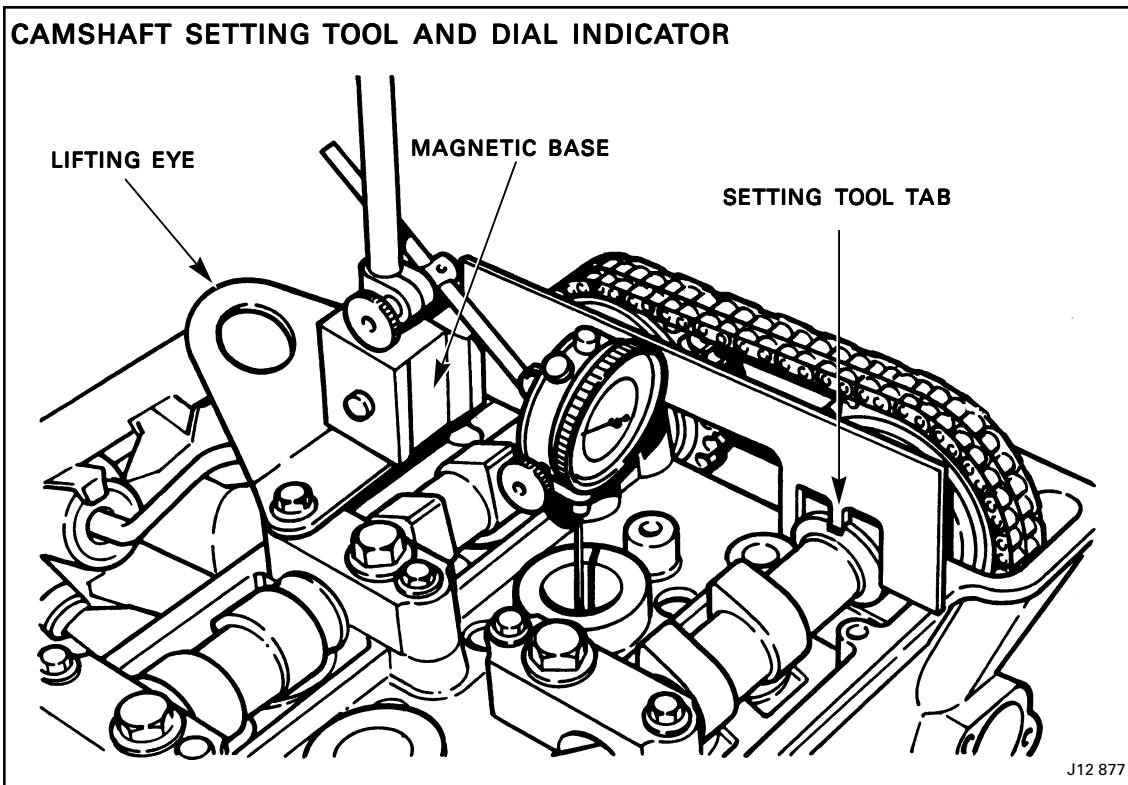

ILLUSTRATION 1

7. On all engines, attach an engine lifting eye to the intake camshaft cap as shown in Illustration 1.
8. Position the magnetic base of a dial indicator gauge on the lifting eye.
9. Install the dial indicator gauge with an extension pointing downward, into the spark plug bore, contacting the top of the piston.
10. Bend back the locking tabs that lock the bolts holding the camshaft sprocket vernier couplings to the camshafts. Loosen the bolts slightly, but do not remove them.
11. Remove the camshaft setting tool. Rotate the crankshaft back and forth slightly across the TDC position to determine the true TDC point for the no. 1 piston and then zero the gauge.

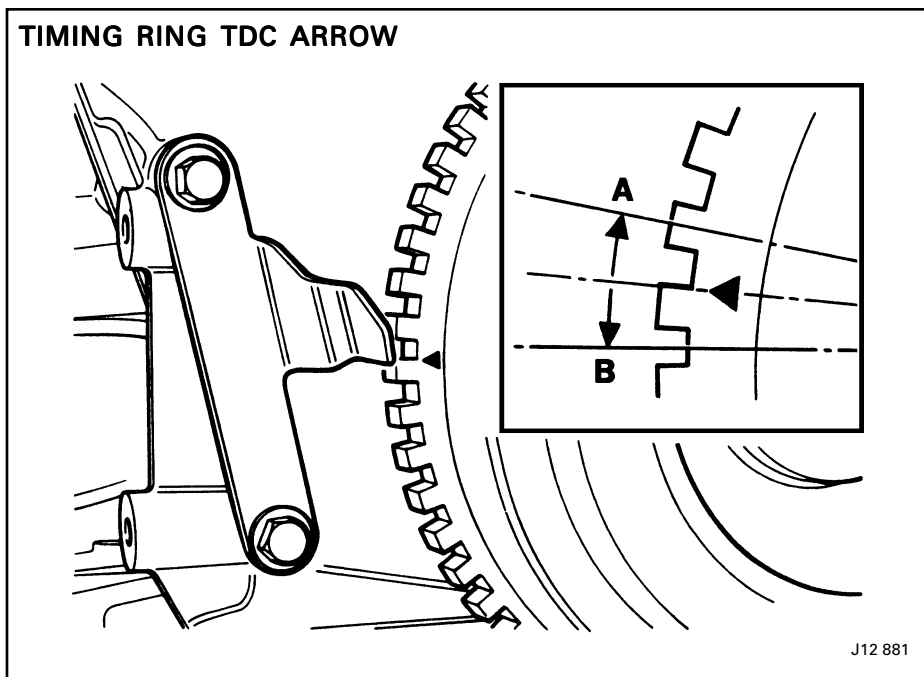

ILLUSTRATION 2

12. Check that the pointer on the front timing cover is in line with the arrowed (TDC) tooth edge on the timing ring, Illustration 2. Realign the pointer if necessary.
13. The crankshaft positions for resetting the camshafts are one and a half teeth on either side of the arrowed (TDC) tooth edge on the timing ring as shown in Illustration 2.
14. Rotate the crankshaft two revolutions in a clockwise direction (viewed from the front of the engine) until the pointer is one and a half teeth before the arrowed (TDC) tooth edge on the timing ring, position A, Illustration 2.

NOTE: Do not release the timing chain tension during this operation since the accuracy of the valve timing depends on maximum chain tension.

15. Remove the retaining bolts and the camshaft sprocket vernier coupling, Illustration 3, from the exhaust camshaft, but do not detach the sprocket from the camshaft flange. The camshaft is free to rotate inside the sprocket with the coupling removed.
16. Position the camshaft setting tool 18G-1433/A across the camshafts with the positioning tab on the exhaust camshaft, Illustration 1.
17. Turn the exhaust camshaft until the tab on the setting tool engages the slot in the camshaft.
18. With the camshaft in this position, reinstall the sprocket vernier coupling to the exhaust camshaft. This step will require several attempts to find the exact alignment of the vernier splines and the bolt holes.

CAMSHAFT SPROCKET VERNIER COUPLINGS

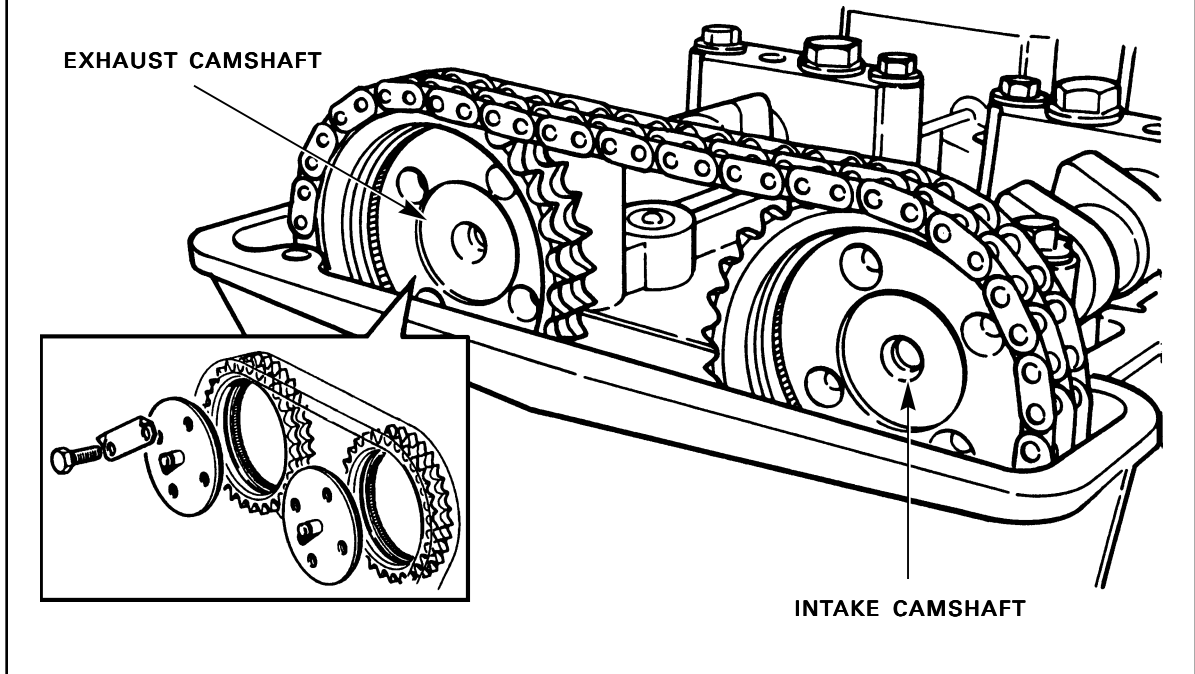

ILLUSTRATION 3

19. Install the locking tabs and the coupling bolts. Lightly tighten the bolts.
20. Remove the setting tool and turn the crankshaft in a clockwise direction (viewed from the front of the engine) until the pointer is one and a half teeth after the arrowed (TDC) tooth edge on the timing ring, position B, Illustration 2.

NOTE: Do not release the timing chain tension during this operation since the accuracy of the valve timing depends on maximum chain tension.

21. Remove the retaining bolts and the camshaft sprocket vernier coupling, Illustration 3, from the intake camshaft, but do not detach the sprocket from the camshaft flange. The camshaft is free to rotate inside the sprocket with the coupling removed.
22. Position the camshaft setting tool 18G-1433/A across the camshafts with the positioning tab on the intake camshaft.
23. Turn the intake camshaft until the tab on the setting tool engages the slot in the camshaft.
24. With the camshaft in this position, reinstall the sprocket vernier coupling to the intake camshaft. This step will require several attempts to find the exact alignment of the vernier splines and the bolt holes.
25. Install the locking tabs and the coupling bolts. Lightly tighten the bolts.

UPPER DAMPER SADDLE IN VISE

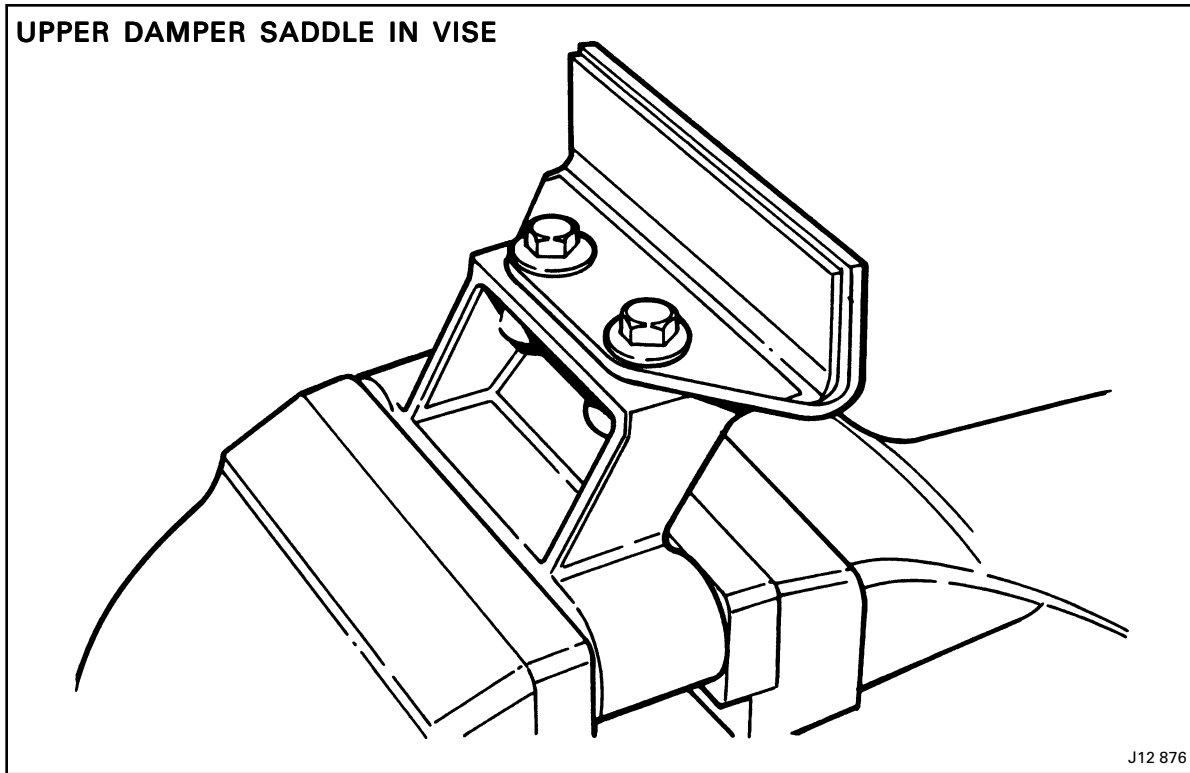

J12 876

ILLUSTRATION 4

26. Remove the setting tool and final tighten the camshaft sprocket vernier coupling bolts to 16.2 - 20.6 lb ft (22 - 28 Nm). Bend the lock tabs against the bolt heads.
27. Check both the settings of one and a half teeth before and after the arrowed (TDC) tooth edge on the timing ring, Illustration 2. The tab of the setting gauge should fit in the slot of the camshaft being checked.
28. Remove the setting tool, the dial indicator gauge, and the lifting eye. Torque camshaft bearing cap bolt to 12.5 - 16.9 lb ft (17 - 23 Nm).
29. On engines with numbers below 9L103934 (XJS Range) or 9J103935 (Sedan Range) only, remove the damper saddle retaining bolts, Illustration 4. Thoroughly degrease the bolts and the saddle. Apply Loctite 545, part number 54531 to the bolt threads and torque to 15.8 - 21 lb ft (21.5 - 28.5 Nm). Install the damper saddle using new cylinder head bolts and torque to 43.5 - 44.9 lb ft (59 - 61 Nm) plus 90 degrees as described in section 2.1 of the AJ16 Engine Service Manual.

NOTE: Engines starting with 9L103934 (XJS Range) or 9J103935 (Sedan Range) do not require modification since the damper saddles are equipped with self locking bolts.

30. Reset the spark plug gaps to 0.038 inch (0.97 mm) and reinstall the spark plugs.
31. Install the camshaft cover using a new seal and new spark plug boss seals.
32. Install the on-plug coils using new gaskets. Install the coil cover using a new seal.

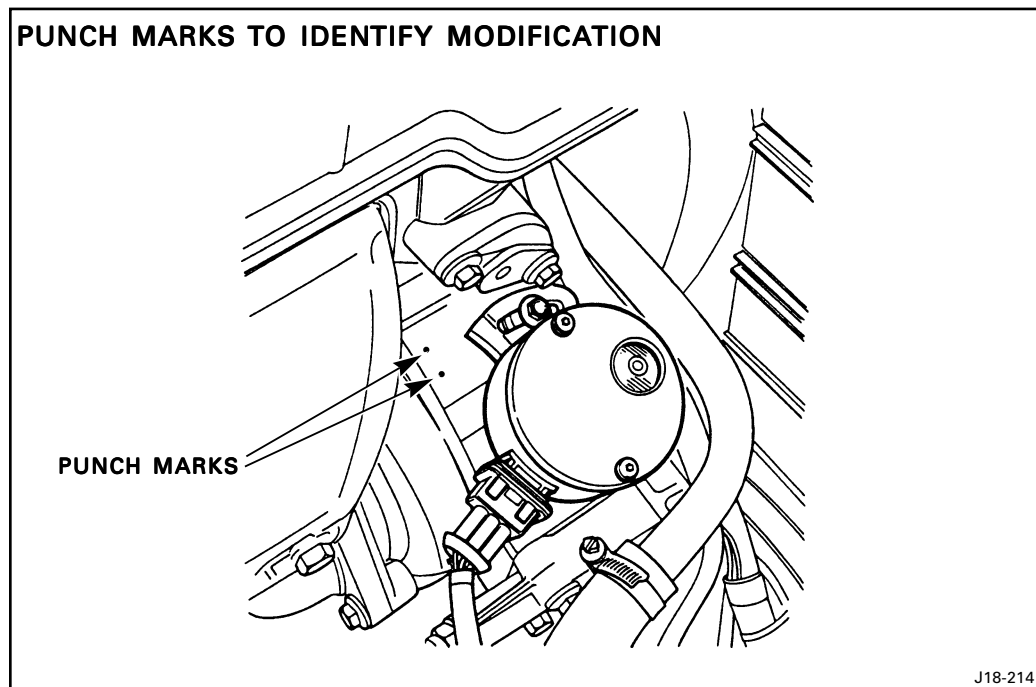

ILLUSTRATION 5

33. Place two punch marks approximately 1/4 inch apart on the timing cover parallel to the lip, Illustration 5, to indicate that the modification was done.
34. Connect the battery negative cable and reset the clock.

PARTS INFORMATION:

<u>DESCRIPTION</u>	<u>PART NUMBER</u>	<u>QTY</u>
Cylinder head bolt (if needed)	JZB 100053	2
Loctite 545 (if needed)	54531	-
Camshaft cover seal	NBC 2525AA	1
Sprocket coupling tab washer	C 33917	4
Spark plug boss seal	NBC 2579AA	6
On-plug coil gasket	DAC 11510	6

WARRANTY INFORMATION:

<u>FAULT CODE</u>	<u>R.O. NUMBER</u>	<u>DESCRIPTION</u>	<u>TIME ALLOWANCE</u>
AD BB LH	12.91.19	Camshaft timing modification (including check tappet clearance)	2.75 hrs.
	10.10.10	Drive in/out	0.15 hrs.

NOTE: Record engine number in the comments section of the claim.