



Sedan Range

DATE 10/95

05.2-07

SERVICE

## TECHNICAL BULLETIN

Poor Drivability/MIL Illumination –  
Check Throttle Synchronization

MODEL	1995 MY XJ12 Sedan
VIN	720001-ON

**ISSUE:**

Diagnostic Trouble Codes (DTCs) may be set if both throttle valves are not synchronized to begin opening at the same time. The Manifold Absolute Pressure (MAP) sensors will detect a difference in pressure between the two intake manifolds, which leads to the setting of DTCs.

The most common codes found are:

P1106          P0106

The following DTCs may also be set:

P0107          P0108  
P0125          P1107  
P1128

Poor throttle valve synchronization may also cause customer complaints of poor drivability and idle quality.

An improved factory procedure for setting the throttle stop screws, using an air flow measuring gauge, was introduced during the 1994 MY production of V12 engines. All 1995 MY V12 engines are set at the factory using this method.

An additional revision was made to the method for setting the throttle linkage to improve synchronized opening of both throttle valves starting with:

<u>Engine no.</u>	<u>VIN</u>
8E118043	745410

**ACTION:**

When diagnosing the following:

- a customer complaint of MIL illumination
- the setting of one or more of the above DTCs
- any drivability or idle complaints

check the throttle valve and linkage settings as described in the following procedure before any further diagnosis or repair.

Perform a road test after adjusting the throttle valves and linkage. If the complaint still exists, refer to Section 5.2 in Volume 2 of the 1995 MY XJ6-XJ12 Electrical Diagnostic Manual.

## SETTING THROTTLE VALVES

**NOTE:** The factory throttle stop setting should not be disturbed unless a noticeable fault is present.

1. Check that both throttle valves are centered horizontally and vertically in the throttle bodies.
2. With the throttle valve closed, use a feeler gauge to check the clearance between the throttle valve and the throttle body (Illustration 1).

Throttle valve checking clearance: 0.001 - 0.003 inch (0.025 - 0.076 mm)

Check the clearance at the bottom as well as at the top of the throttle valve. If a significant difference is found between the top and bottom measurements, the throttle valve may be offset on its shaft. If both measurements are within the above range, do NOT adjust the throttle stop screw (Illustration 1).

3. If adjustment is necessary, set the throttle stop screw to achieve the following throttle valve clearance range:

Throttle valve setting clearance: 0.001 - 0.0015 inch (0.025 - 0.04 mm).

After completing throttle valve adjustment, seal the locknuts with a dab of paint.

4. Repeat the checking procedure on the opposite throttle valve.

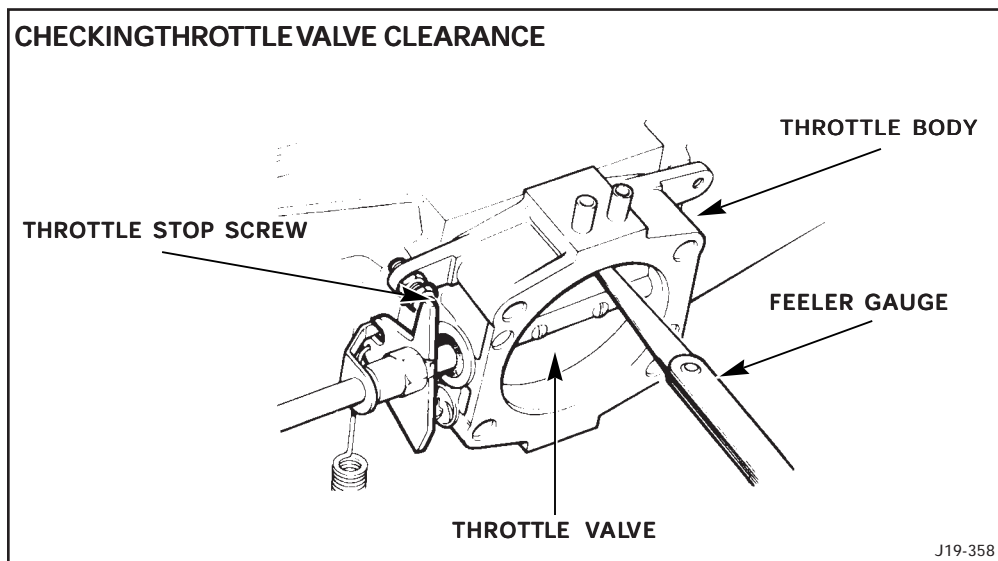

ILLUSTRATION 1

## SETTING THROTTLE LINKAGE

**NOTE:** Starting with VIN 745410, the linkage has been set at the factory using special equipment to obtain simultaneous opening of both throttle valves. Do not change these settings unnecessarily.

Use the following procedure to obtain the required backlash in the throttle linkage to ensure correct synchronization of throttle opening.

1. Loosen both locknuts on the two linkage rods between the center throttle turntable and the throttle levers.
2. Disconnect one linkage rod from its ball pin on the linkage rod bracket.
3. Position a 0.079 inch (2.00 mm) spacer between the linkage rod bracket and its stop (Illustration 2).

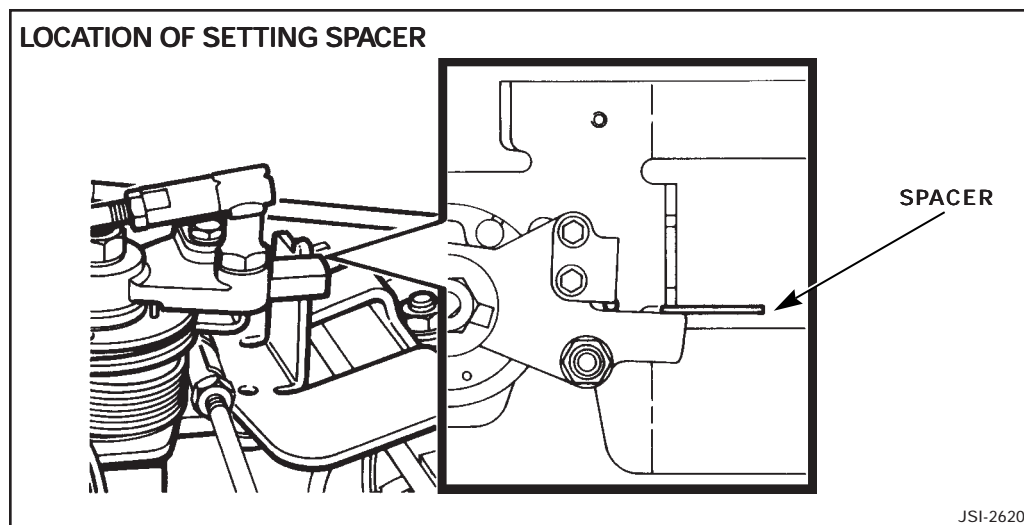

ILLUSTRATION 2

4. Turn the linkage rod that is still connected to increase its length until the throttle lever clears its stop screw.
5. Shorten the linkage rod until the throttle lever just touches its stop screw. Tighten both lock nuts on the linkage rod.
6. Connect the second linkage rod and repeats steps 4 and 5 to adjust its length.
7. Remove the spacer inserted between the linkage rod bracket and its stop.
8. Check the backlash by turning the linkage rod bracket of the throttle turntable slightly clockwise. A gap should appear between the bracket and its stop before either throttle lever leaves its stop screw.  
Gap dimension: 0.062 - 0.094 inch (1.57 - 2.39 mm)
9. Both throttle levers should leave their stops at the same time. Satisfactory synchronization is possible if the second throttle lever moves from its stop after the first throttle lever within a maximum additional increase of 0.030 inch (0.76 mm) in the gap.

10. Release the linkage rod bracket to allow the turntable to return to the closed throttle position. Check that the linkage rod bracket is now in contact with its stop. If any gap is present, repeat steps 1 through 10.

Perform a road test after adjusting the throttle valves and linkage. If the complaint still exists, refer to Section 5.2 in Volume 2 of the 1995 MY XJ6-XJ12 Electrical Diagnostic Manual.

**WARRANTY INFORMATION:**

<b>FAULT CODE</b>	<b>R.O. NUMBER</b>	<b>DESCRIPTION</b>	<b>TIME ALLOWANCE</b>
CD GB GG	19.20.05	Throttle linkage check and adjust	0.25 hrs.
CD KF GG	19.20.11	Throttle valves - engine set - check and adjust	0.40 hrs.
CD GB GG CD KF GG	19.20.40	Throttle valves and linkage - engine set - check and adjust	0.60 hrs.

**NOTE:** If the MIL is illuminated, complete and Diagnostic Trouble Code Report (Form S-93) as described in Administration Bulletin 3-133 Amended 7/95.