



Sedan Range

DATE 2/95

05.2-10

SERVICE

TECHNICAL BULLETIN

Fuel Tank Fill – Tank Will Not Fill
Above 3/4 – Replace Fuel Tank –
Service Action 626

MODEL 1995 MY
XJ12 Sedan
VIN 720001-724559

ISSUE:

The fuel tank will not fill above 3/4 full.

Service station gas pumps that deliver less than 8 gallons per minute may not be able to completely fill the fuel tanks of 1995 MY Sedan Range vehicles (VIN 720001 – 724559).

ACTION:

If a customer complains that the fuel tank of a 1995 MY Sedan Range vehicle within the VIN range cannot be filled above approximately 3/4 full, replace the fuel tank assembly with a new fuel tank assembly. Follow the procedure detailed below.

NOTE: Perform this action on a customer complaint basis only.

FUEL TANK ASSEMBLY REPLACEMENT PROCEDURE:

1. Depressurize the fuel system following the instructions in the Service Manual Section 5.1.3.
2. Remove the trunk carpet and front liner.
3. Disconnect the battery negative cable.
4. Remove the left side rear lamp interior finisher, trunk seal retainer, and left side trunk liner.
5. Drain the fuel tank.

WARNING: Use only approved equipment to drain the fuel tank. Observe all safety precautions when working on the fuel system.

6. Raise the vehicle. Use tool JD 203 to disconnect the fuel tank supply and return lines. Plug all open fuel lines to prevent leakage and contamination.
7. Disconnect the fuel filler drain hose under the vehicle.
8. Lower the vehicle. Remove the CD player and amplifier (where applicable) from the fuel tank evaporative flange area and set aside.
9. Disconnect the vehicle harness from the evaporative loss flange and disconnect the fuel tank sender unit connectors.

10. Remove the tie straps securing the filler drain hose to the filler neck. Remove the filler drain hose spring clamp (Illustration 1) and remove the drain hose from the body grommet.

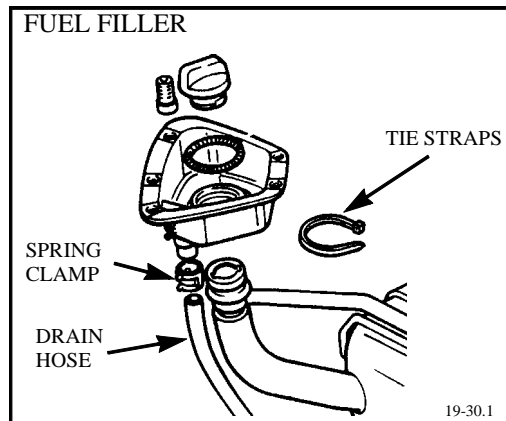

ILLUSTRATION 1

11. Disconnect the vapor line from the fuel tank using tool JD 203.
12. Remove the fuel filler cap to access the filler neck seal spring.
13. Remove the filler neck spring from around the filler neck seal and pull the seal up, free of the filler neck (Illustration 2).

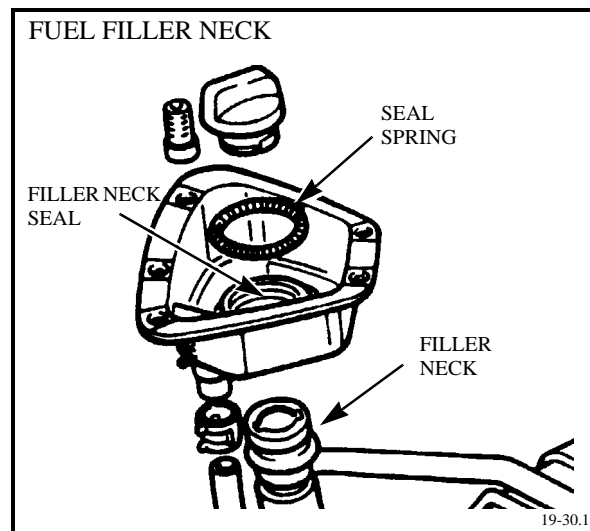

ILLUSTRATION 2

14. Loosen the fuel tank retaining strap tensioning bolts at the lower brackets (Illustration 3). Remove the bracket retaining bolts. Leave the brackets attached to the retaining straps.

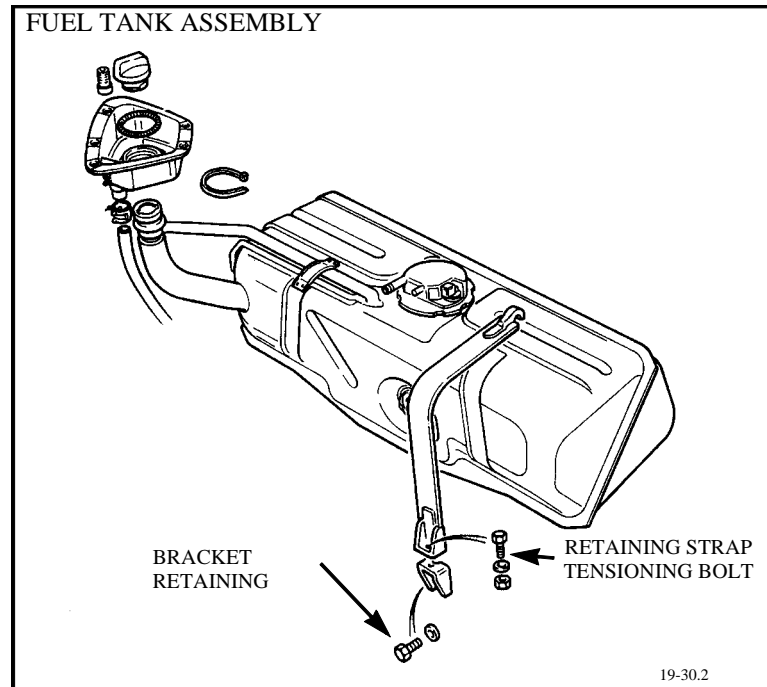

ILLUSTRATION 3

15. Tape the retaining straps to the bulkhead, clear of the tank.
16. Support the trunk lid and remove the left side trunk lid support strut retaining clip. Detach the strut from the trunk lid.
17. Remove the fuel tank and drain any remaining fuel from the tank.

WARNING: Observe all safety precautions when working on the fuel system

18. Install the replacement tank by reversing the steps above.
19. Transfer the drained fuel to the newly installed tank.
20. Connect the battery and check the fuel system for leaks and proper operation.
21. Reset the clock to the correct time.

PARTS INFORMATION:

<u>DESCRIPTION</u>	<u>PART NUMBER</u>
Fuel tank assembly - Sedan Range (4.0L Normally Aspirated)	NNA 5908FD/1K
Fuel tank assembly - XJR (4.0L Supercharged) and XJ12 Sedan	NNA 5908EB/1K
Tie strap	C 46294

WARRANTY INFORMATION

Service Action S626

<u>VEHICLE</u>	<u>SUMMARY CODE</u>	<u>DESCRIPTION</u>	<u>TIME ALLOWANCE</u>
Sedan Range (4.0L Normally Aspirated) 1995 MY VIN 720001 - 724559	GA	Replace fuel tank - No drive in/out time	2.15 hrs.
Sedan Range (4.0L Normally Aspirated) 1995 MY VIN 720001 - 724559	GB	Replace fuel tank - Only repair performed - With drive in/out time	2.30 hrs.
XJR (4.0L Supercharged) and XJ12 Sedan 1995 MY VIN 720001 - 724559	GC	Replace fuel tank - No drive in/out time	2.35 hrs.
XJR (4.0L Supercharged) and XJ12 Sedan 1995 MY VIN 720001 - 724559	GD	Replace fuel tank - Only repair performed - With drive in/out time	2.50 hrs.

CLAIM SUBMISSION PROCEDURE:

Warranty summary codes have been assigned to this service action in order to simplify claim submission. The dealership will be reimbursed the parts and labor time allowance as indicated.

DCS Dealers

Submit claims using the appropriate summary code for the vehicle model and work performed. Follow standard campaign submission procedures.

Non-DCS Dealers

Submit claims on the Recall Campaign Summary form W-25. Enter the appropriate summary code for the vehicle model and work performed in the Repair Code column. Do not use the W-1 warranty claim form.