



Sedan Range

DATE 10/95
Amended 7/00

08.2-01

SERVICE

TECHNICAL BULLETIN

Transmission MIL Illumination – Revised EPROM – Replacement Procedure

MODEL 1995 MY
XJR and XJ12
VIN
720028 - 754303

Remove and destroy Bulletin 08.2-01, dated 10/95.
Replace with this Bulletin.
Revisions are marked with a bar and in **bold text**.

ISSUE:

Some 1995 MY Sedan Range vehicles equipped with 4L80-E automatic transmissions may experience repeated Malfunction Indicator Lamp (MIL) illumination and setting of one or more of the following Diagnostic Trouble Codes (DTCs) even though no actual faults exist in the transmission:

- P0706 Manifold pressure switch
- P0756 Transmission solenoid B
- P1739 Transmission slip

A revised Erasable Programmable Read Only Memory (EPROM) chip is now available for the Transmission Control Module (TCM) on XJR and XJ12 models.

Note: Do not replace the TCM for the above conditions.

ACTION:

If a Sedan Range vehicle within the above VIN range exhibits repeated transmission MIL illumination with DTCs P0706, P0756, and P1739, proceed as follows:

EPROM REPLACEMENT PROCEDURE

1. Connect the PDU to the vehicle and make the following menu selections: Diagnostics, Toolbox, Engine and Transmission, Datalogger, GM 4L80-E Transmission. Select Transmission Oil Temperature (TOT).
2. Drive the vehicle to bring the transmission fluid temperature to 194° F (90° C).

CAUTION! Do not use a stall test procedure to raise the fluid temperature.

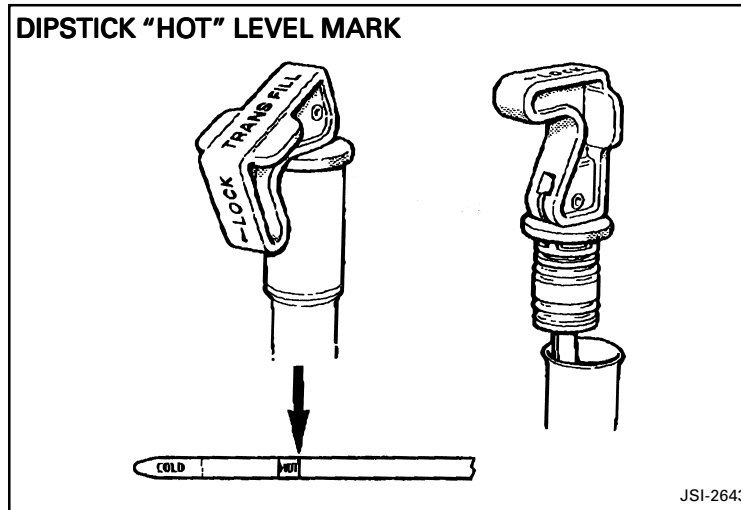

ILLUSTRATION 1

3. Check the transmission oil level with the vehicle parked on level ground. The oil level should be at the top line of the HOT area marked on the dipstick (Illustration 1).
4. Remove the TCM (Illustration 2). The TCM is located under the passenger side underscuttle. The mounting bracket is the same as for ZFTCMs. Refer to repair operation 44.15.32 in subsection 8.1.3 of the XJ6 - XJ12 Vehicle Service Manual.

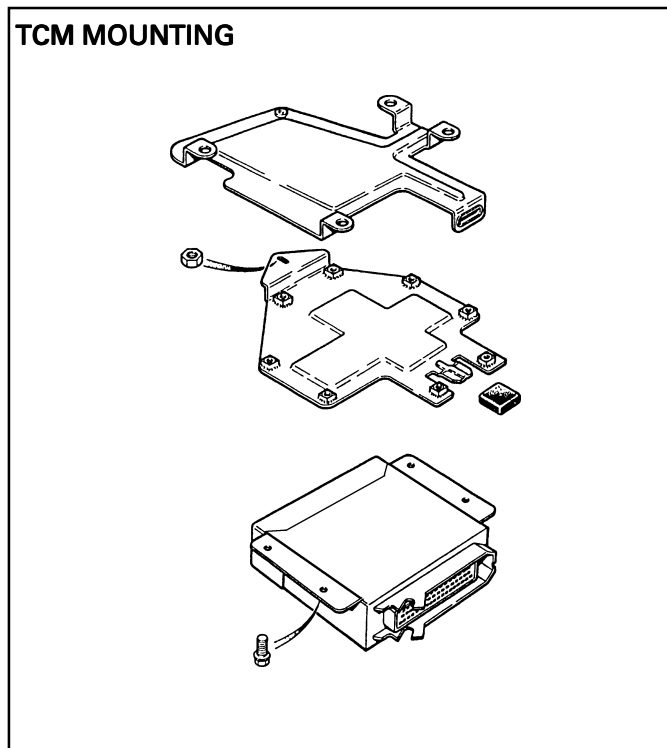

ILLUSTRATION 2

5. Place the TCM on a clean bench area and remove the TCM inspection cover (Illustration 3).

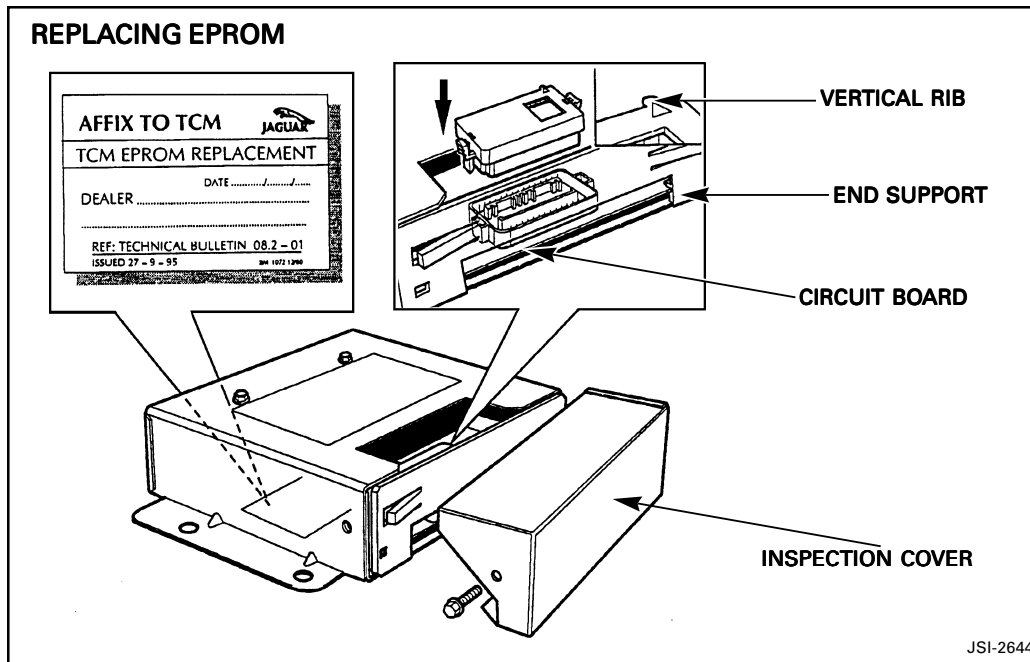

ILLUSTRATION 3

CAUTION! The end support (Illustration 3) is free to move when the inspection cover is removed and must be held in place. Support the circuit board through the opening in the end support to prevent the board from bending and possibly cracking while removing and installing the EPROM.

6. The EPROM has a retaining latch at each end. These latches must be pressed in while removing the EPROM from the socket. Press the latches inward and ease each latch free of the socket. Then, carefully remove the EPROM module from the circuit board.
7. Align the vertical rib (Illustration 3), indicated by an arrow, on the replacement EPROM with the rib on the socket to ensure correct alignment.

CAUTION! The EPROM can only be installed in one direction. DO NOT use excessive force to install it.

Install the replacement EPROM module in the board socket while holding the board through the opening in the end support. Press the EPROM down into the socket until the latches engage.

8. Reinstall the inspection cover.
9. Fill out and attach the label supplied with the revised EPROM, to the bottom of the TCM, opposite the identification label. Do not damage or cover the TCM identification label.

10. Install the TCM in the vehicle. Refer to repair operation 44.15.32 in subsection 8.1.3 of the XJ6 - XJ12 Vehicle Service Manual.
11. Use the PDU to check for any DTCs stored in the TCM. Record any DTCs found on a Diagnostic Trouble Code Report Form (Form S-93) before clearing them.
12. Road test the vehicle to ensure that the condition has been eliminated.

NOTE: The EPROMs for the 4.0L SC and the 6.0L V12 applications are **not** interchangeable.

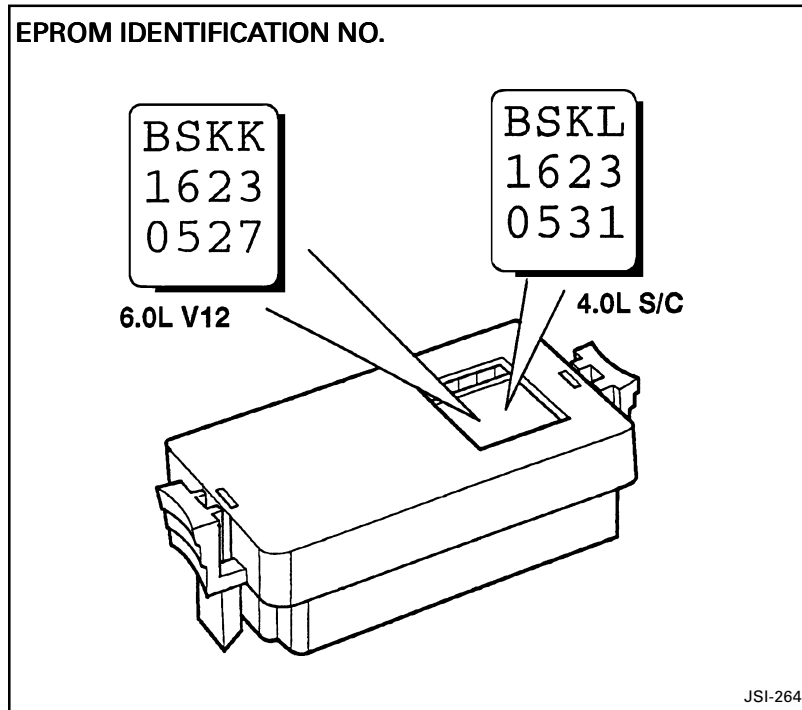

ILLUSTRATION 4

PARTS INFORMATION:

<u>DESCRIPTION</u>	<u>IDENTIFICATION NO.</u>	<u>PART NUMBER</u>	<u>QTY.</u>
EPROM Module, XJR	BSKL 1623 0531	JLM 12442	1
EPROM Module, XJ12	BSKK 1623 0527	JLM 12441	1

WARRANTY INFORMATION:

<u>FAULT CODE</u>	<u>R.O. NUMBER</u>	<u>DESCRIPTION</u>	<u>TIME ALLOWANCE</u>
FX CB ZZ	44.91.13	TCM, modify with revised EPROM	0.65 hrs.
	10.10.10	Drive in/Drive out	0.15 hrs.