



Sedan Range

DATE 11/98

13-39

SERVICE

## TECHNICAL BULLETIN

### Sliding Roof – Diagnosis & Repair

MODEL 1995-97 MY  
Sedan Range  
VIN  
720001-812255

**Issue:**

This Bulletin is issued to clarify the correct procedures for the elimination of problems concerning the Sliding Roof Assembly.

**Action:**

The operations covered in this bulletin are as follows:

- Diagnosis, page 2.
- Tilt and Slide Mechanism removal, page 3.
- Tilt and Slide Mechanism installation, page 5.
- Water ingress around Furflex seal, page 7.
- Water ingress through sliding roof mechanism frame, page 8.
- Reporting procedure, page 8.

## DIAGNOSIS

The sliding roof assembly electrical system must be tested before the mechanism is investigated.

1. Lower the roof console to provide access to the sliding roof motor and its harness connector.
2. Connect the PDU to the vehicle and select 'Sliding Roof Motor'.
3. Ensure that the sliding roof is fully closed, either electrically or mechanically.
4. Follow the instructions on the PDU screen. Use the current probe to check the measurement at the motor harness connector.

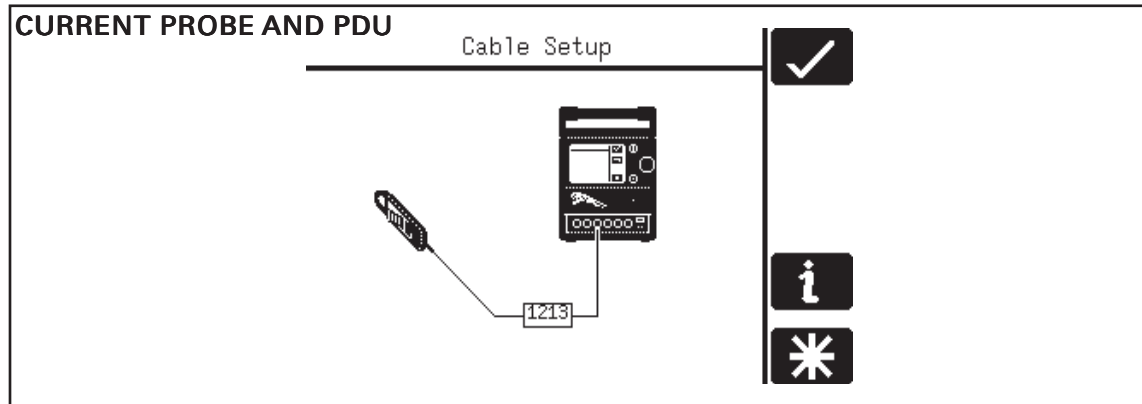

ILLUSTRATION 1

5. Press and hold the sliding roof switch in the open position and read the current.
6. Press and hold the sliding roof switch in the close position and read the current.

**Note:** The operating current should be 3.5 Amp when sliding and 6.0 Amp maximum, with an average, recorded on the PDU, of the two figures, i.e. around 4.75 Amp.

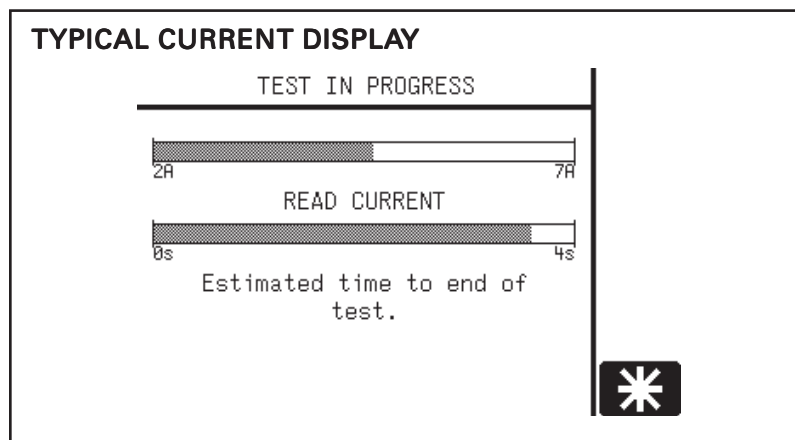

ILLUSTRATION 2

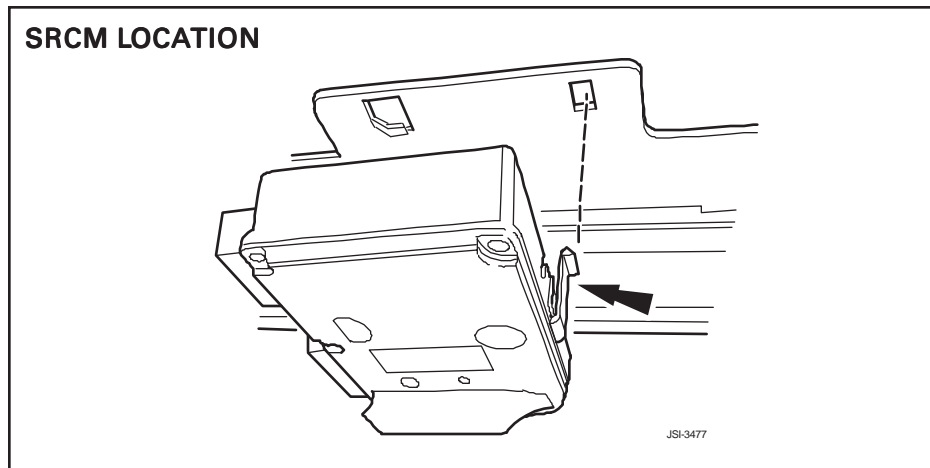

ILLUSTRATION 3

- Intermittent operation can be caused by the Sliding Roof Control Module, (SRCM), not being correctly located against the cables.
- The SRCM retaining tang (arrow) should be firmly engaged in the base plate, as indicated in Illustration 3, and secured by a tie-strap between the cables.

#### TILT AND SLIDE MECHANISM REMOVAL

- If the sliding roof has not fully closed, use a drive key or screwdriver in the slot in the gearbox shaft (indicated in Illustration 4) to rotate the shaft to manually close the sliding roof.

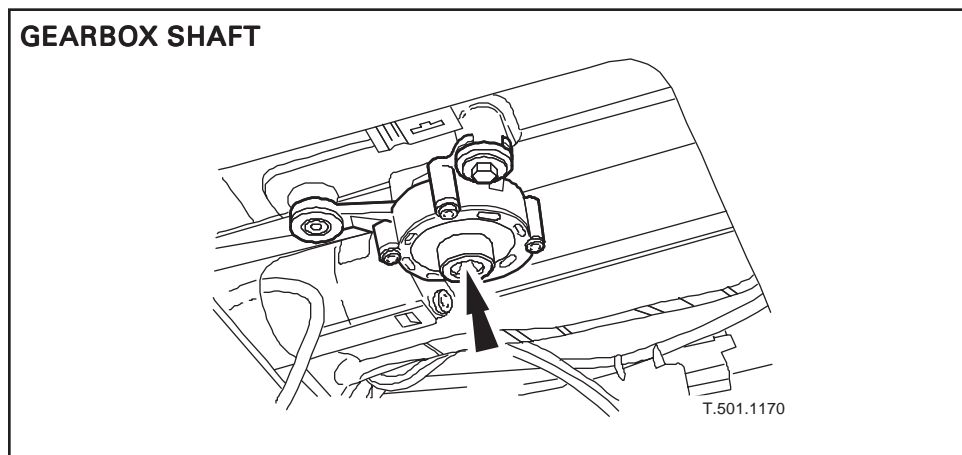

ILLUSTRATION 4

- If the electrical drive and controls are verified as fault free, remove the sliding roof assembly, as detailed in JTIS 5, Section 501-17, SRO 76.82.01, to inspect the mechanical components.

**Note:** A replacement tilt and slide mechanism is available as a left or right side component.

1. After removing the sliding roof and the mechanism from the vehicle, place the mechanism on a suitable bench and then remove the SRCM and the motor.

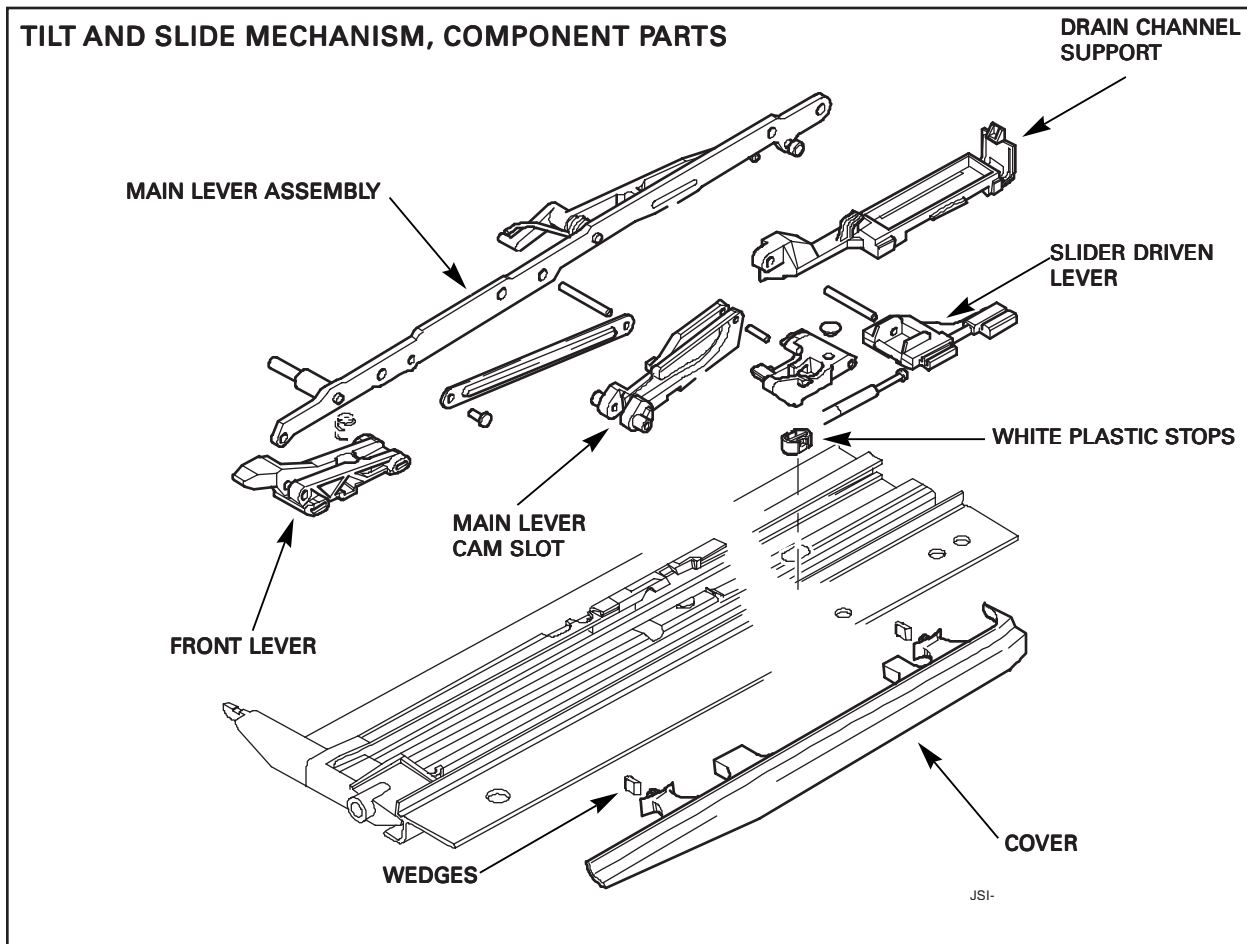

ILLUSTRATION 5

2. Remove the white plastic stops, (Illustration 5), from the track.
3. Remove the wedges, (Illustration 5), from the split locating pins and pull the pins through the holes to remove the cover from the mechanism.
4. Remove the rubber plug from the end of the channel.
5. Pull on the defective mechanism to pull the mechanism and the cable to the end of the channel.

**Note:** With the SRCM and the motor removed, the drive cable is free to be removed from the channel.

- The first item to slide out of the channel will be the support (H, Illustration 6) for the drain channel. Pull the support to remove it while maintaining downward pressure, (dashed arrow, Illustration 6), on the bell crank lever arm (C) against the spring pressure.

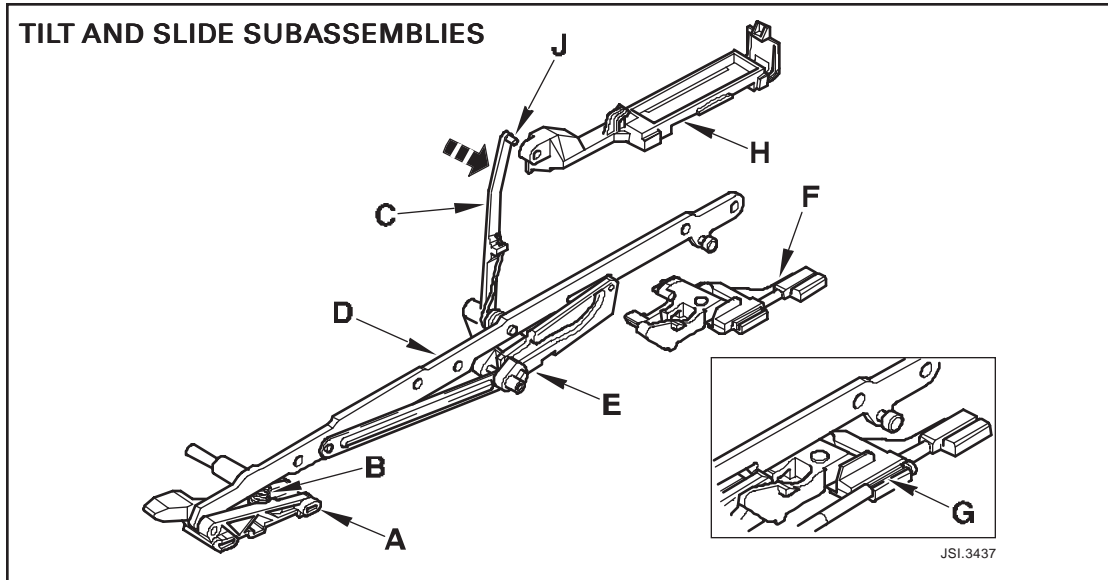

ILLUSTRATION 6

- Detach the support (H) and remove it as soon as the bell crank lever arm, (C, Illustration 6), reaches the end of the channel.
- Slowly pull out the mechanism, while maintaining pressure on the bell crank lever arm, to expose the cable end, (G, Illustration 6), lift the drive cable end from the slot in the slider driven lever (F) and then withdraw the assembly from the channel until the main lever assembly (D) can be detached.
- Maintain pressure downwards on the bell crank lever arm, and pull the assembly from the channel and then slowly release the bell crank lever arm to relax the spring.

#### TILT AND SLIDE MECHANISM INSTALLATION

- Clean the channel of dirt and old lubricant.
- Lightly lubricate, using a small brush, the channel, in the areas indicated in Illustration 7, the front lever spring, (B, Illustration 6), both cam slots, (E, Illustration 6), and the slot for the main lever pin with the approved lubricant, listed in 'Parts Information'.
- The tilt and slide mechanism is supplied, (left or right side), as a replacement

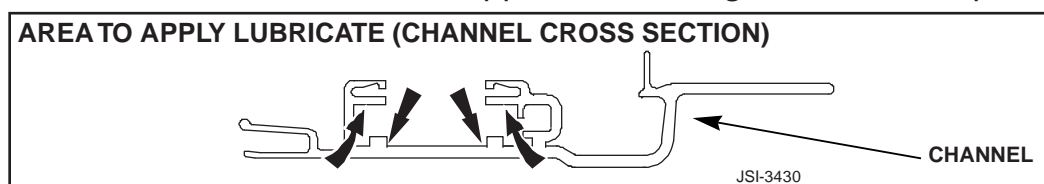

ILLUSTRATION 7

kit of sub assemblies, as shown in Illustration 6, and not in component form as shown in Illustration 5. The sub assemblies are shipped in a spare section of rail to keep them aligned correctly. This provides a convenient reference for proper assembly. The rail is **not** intended for installation and should be discarded.

4. Insert the front lever (A, Illustration 6) in the channel making sure that the front lever spring (B, Illustration 6), is in position.
5. When the front lever is fully located, rotate the bell crank lever arm, (C, Illustration 6), to pre-load the spring and then hold the arm against the lift mechanism, (D, Illustration 6).
6. Insert the dowels and the square reaction pin of the main lever, (E, Illustration 6), in the channel. The small arm of the bell crank lever arm can now locate against the channel to prevent the crank rotating.
7. Slowly release the bell crank lever arm to relax the spring.
8. Position the driven lever assembly, (F, Illustration 6), so that the forward dowel of the driven lever engages in the rear of the main lever cam slot (E) and the hook engages with the roller pin at the rear of the lift mechanism.
9. Press the assembly into the channel until the foot of the driven lever (F) is engaged in the channel and then engage the end of the drive cable, (G, Illustration 6), in the slot in the driven lever.
10. Place the support of the drain channel, (H, Illustration 6), on the pivot pin, (J, Illustration 6), at the end of the bell crank lever arm. Depress the lever to release the spring load and then push the assembly, plus the support, fully into the channel.
11. Reinstall the split locating pins of the mechanism cover through the lift mechanism and secure them with the wedges, (B, Illustration 5) and reinstall the white plastic stops, (A, Illustration 5), on the track.

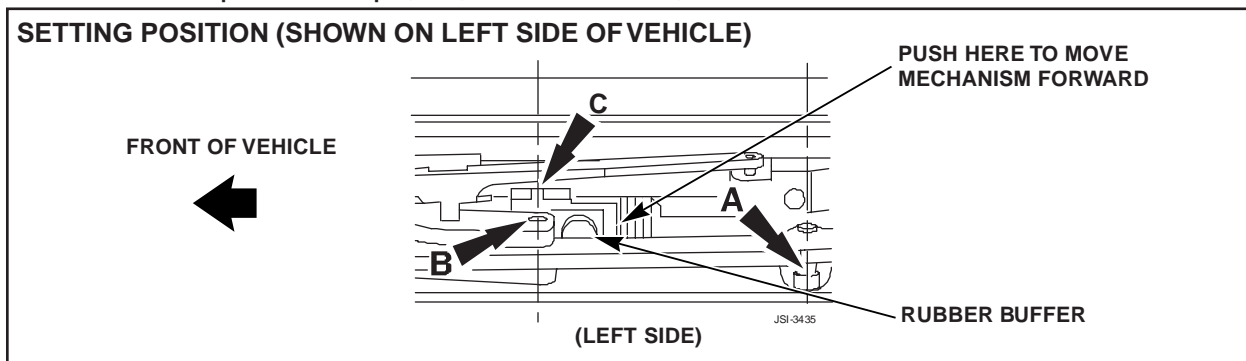

ILLUSTRATION 8

12. Move both mechanisms forward until they reach the "panel closed" position as follows:
  - the mechanism is **raised** out of the channel and is parallel to the channel,
  - the roller pin, A, Illustration 8, is raised out of the circular cutout and is centered over the circular cutout in the channel,
  - the pivot pin through the main lever, B, is aligned with the rib on the top of the sliding lever, C.

This is the position that the mechanisms are in when the sliding roof panel pops up flush with the roof.

- When both mechanisms are in this setting position, insert the motor assembly to mesh with the drive cables and secure the motor with the mounting screws.

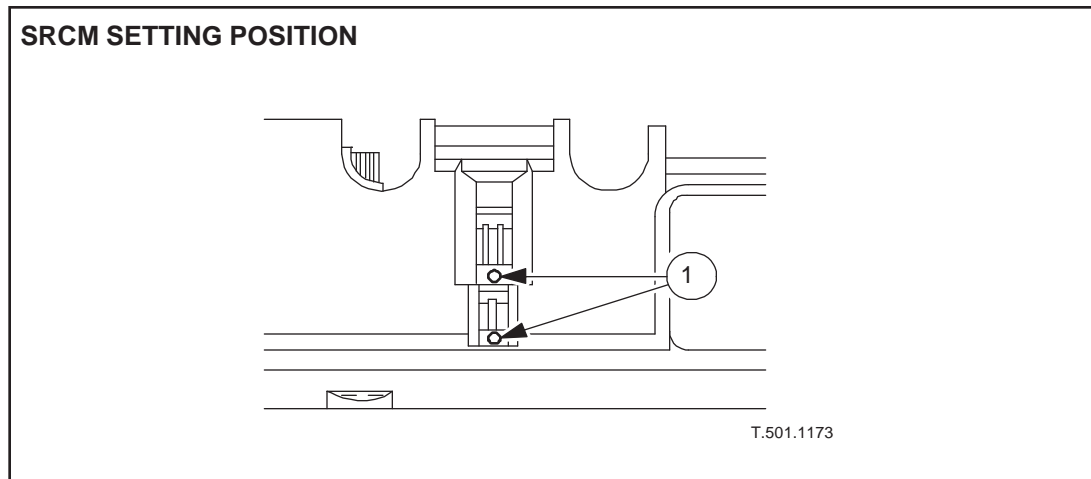

ILLUSTRATION 9

- The SRCM should be re-timed, with the two dots aligned, (1, Illustration 9), and then installed on the assembly.
- Using a drive key or screwdriver in the slot in the gearbox shaft, (indicated in Illustration 4), rotate the shaft  $\frac{1}{4}$  turn counter clockwise to reengage the motor drive so the shaft drops into position, level with the edge of the housing.
- Reinstall the sliding roof assembly as in JTIS 4, Section 501-17, SRO 76.82.01.

#### WATER INGRESS AROUND FURFLEX SEAL.

If water is entering the sliding roof panel area by the rear of the Furflex seal, the seal must be removed and discarded and a new seal installed, as follows:

- Thoroughly clean the roof panel inner and outer edge.

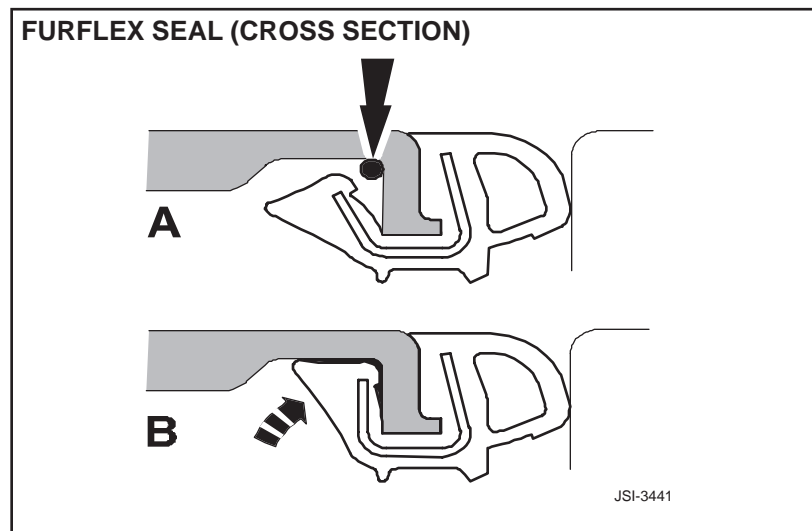

ILLUSTRATION 10

- Apply a narrow bead of sealant to the inner angle of the roof panel, (A, Illustration 10), all around the panel. Install the seal on the panel and trim to length.

## CRIMPING TOOL

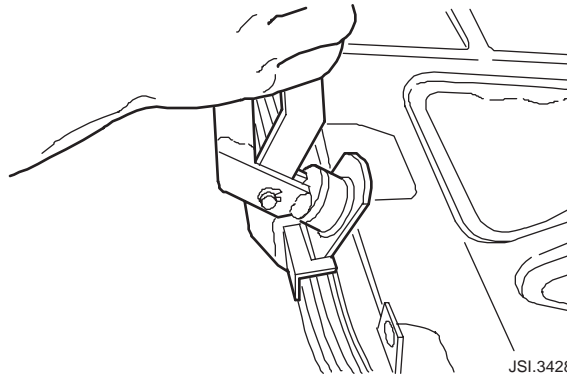

ILLUSTRATION 11

**Note:** The appropriate sealant is listed under Parts Information.

3. Crimp the seal into position using ServiceTool 501-023, as shown in Illustration 11.
4. When the seal is crimped into position, (B, Illustration 10), the sealant is compressed and spread around the roof panel inner face to provide a barrier to water ingress.

**Note:** Do not allow any sealant to contact the Furflex face of the seal.

## WATER INGRESS THROUGH SLIDING ROOF MECHANISM FRAME

- If the headlining shows a stain within 100 mm (4 inches) radius of the front corners of the aperture this is evidence of a water leak through the sliding roof frame.
- If the sliding roof frame is responsible for a water leak, then replace the assembly by a new item.

## REPORTING PROCEDURE

Any example of a serious defect in the Sliding Roof mechanism must be reported to the Product Investigation Dept. on an S-94 form faxed to 201-818-9763.



## Parts Information:

<u>DESCRIPTION</u>	<u>PART NUMBER</u>
Sliding Roof Assembly	HNA 1772AA
Tilt and slide mechanism - Right side	HNA 1752AA
Tilt and slide mechanism - Left side	HNA 1753AA
Support drain channel - Right side	HNB 1774AA
Support drain channel - Left side	HNB 1775AA
Mechanism cover - Right side	HNA 1758AA
Mechanism cover - Left side	HNA 1759AA
TEFOIL 184-18-934	obtain locally
Low-temperature grease (good for 10 cars)	JLM 12068

## Warranty Information:

<u>FAULT</u>	<u>R.O.</u>	<u>DESCRIPTION</u>	<u>TIME</u>
<u>CODE</u>	<u>NUMBER</u>		<u>ALLOWANCE</u>
VB DB **	76.82.49	Sliding RoofTilt & Slide Mechanism Cover - left side - renew	0.15 hrs.
VB DB **	76.81.50	Sliding RoofTilt & Slide Mechanism Cover - right side - renew	0.15 hrs.
VB DB **	76.82.51	Sliding RoofTilt & Slide Mechanism Cover - vehicle set - renew	0.25 hrs.
VB ** **	76.82.52	Sliding Roof RearTrim Panel Lower Support - left side - renew	2.65 hrs.
VB ** **	76.82.53	Sliding Roof RearTrim Panel Lower Support - right side - renew	2.65 hrs.
VB ** **	76.82.54	Sliding Roof RearTrim Panel Lower Support - vehicle set - renew	2.65 hrs.
VB DB **	76.82.55	Sliding RoofTilt & Slide Mechanism - left side - renew	2.75 hrs.
VB DB **	76.82.56	Sliding RoofTilt & Slide Mechanism - right side - renew	2.75 hrs.
VB DB **	76.82.57	Sliding RoofTilt & Slide Mechanism - vehicle set - renew	2.85 hrs.