

Interior and Fascia Panel Lighting Malfunctions – Harness Chafing Behind Radio

MODEL 1995 MY
Sedan Range
VIN 720001-ON

ISSUE:

1995 Sedan Range vehicles may experience fascia panel lighting and interior lighting malfunctions that can be caused by the back of the radio (Illustration 1) chafing on the fascia harness, In-Car Entertainment (ICE) system harness or the center console harness (Illustration 2).

Some conditions found to be caused by harness chafing include:

- Dimmer module fuse blows - shorted to ground.
- No locate lighting.
- No interior lighting.
- All interior lighting remains ON - ground wire from module constantly grounded.
- Control panel illumination flickering.
- Hazard flasher light remains ON at all times.
- Climate Control panel inoperative.

ACTION:

In case of a customer complaint of conditions similar to those listed above or when performing work on the radio on a Sedan Range vehicle within the above VIN range, check that no chafing of the harness is occurring as follows:

1. Remove the radio, switch pack and climate control panel as an assembly (refer to 13.3.10 in Section 13 of the XJ6 - XJ12 Vehicle Service Manual).

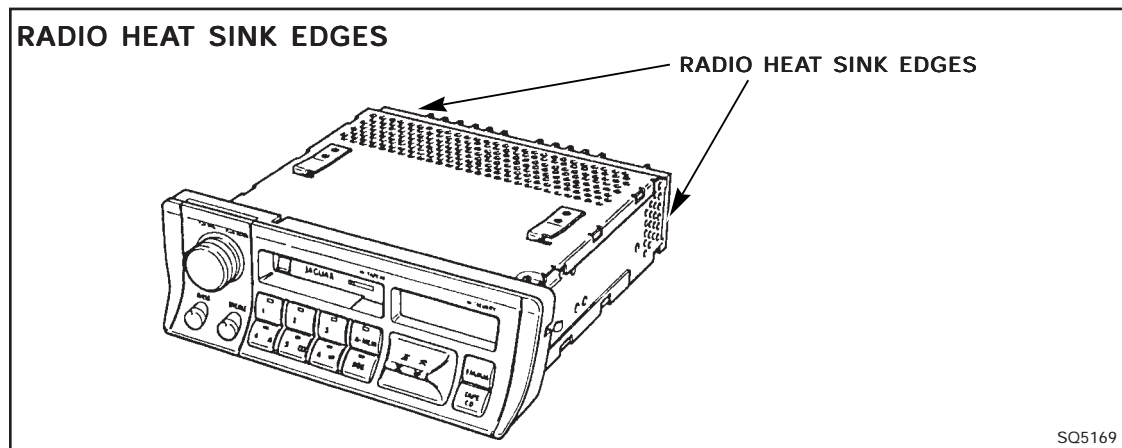

ILLUSTRATION 1

2. Check the harnesses running along the console and behind the radio (Illustration 2) for evidence of chafing.

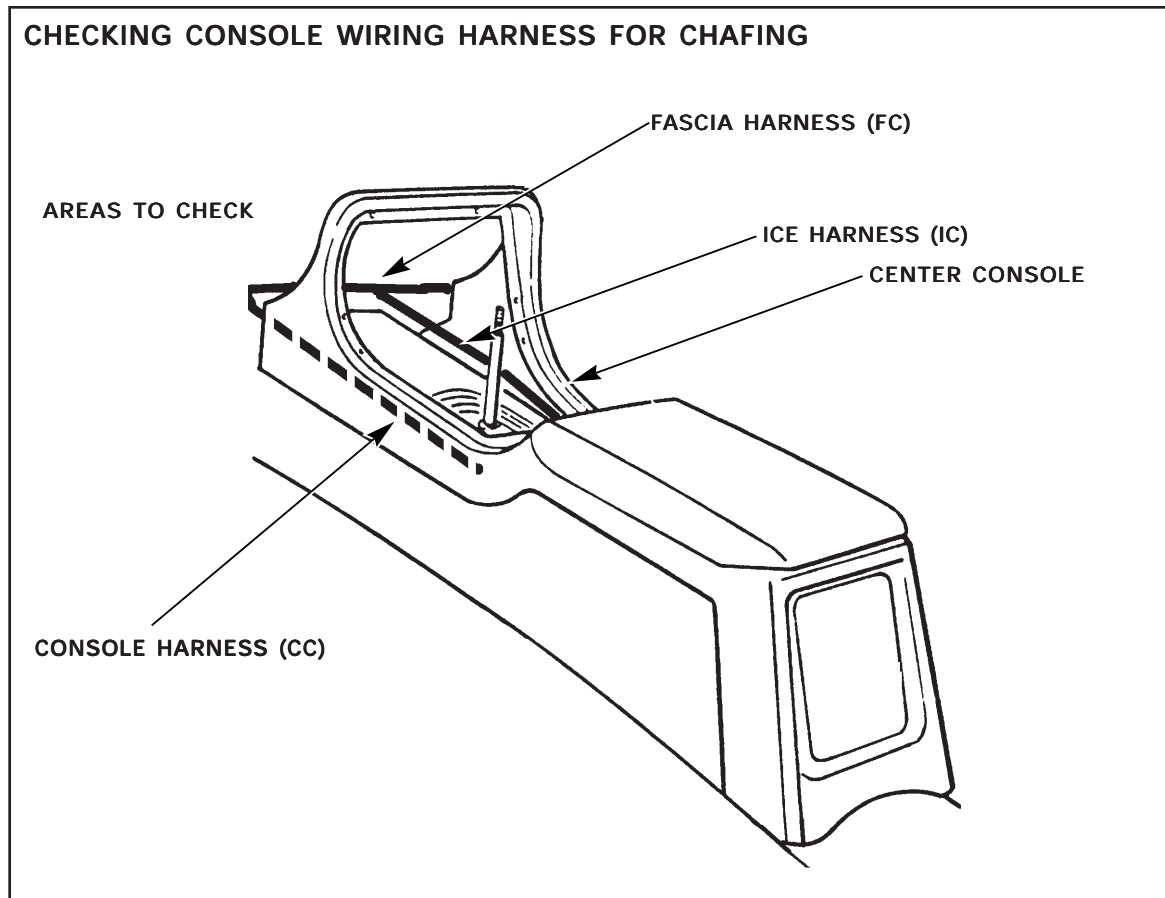

ILLUSTRATION 2

3. If chafing is found, repair the wires, apply suitable protection such as 3M Glass Cloth Tape (part no. 27 or 69) or convoluted tubing to the harness and secure the harness away from the sharp edges of the radio chassis and heat sink.
4. Check the operation of the systems listed on page 1.
5. Reinstall the climate control panel and the radio.
6. Check the operation of all systems.

WARRANTY INFORMATION:

FAULT CODE	R.O. NUMBER	DESCRIPTION	TIME ALLOWANCE
LD RC BT	86.70	Repair chafed console harness	shop time
LD QC BT	86.70	Repair chafed ICE harness	shop time
LB KC BT	86.70	Repair chafed fascia harness	shop time