



V8 XJ Series/XK8

DATE 04/98
Amended 04/02

206-07

SERVICE

TECHNICAL BULLETIN

Selector Lever Difficult Shift From Park – Brake Lamps Remain Lit – Failsafe Message – Revised Brake Pedal And Switch

MODEL
1997-2000 MY XK Range
1998-2002 MY V8 XJ Series
VIN
001001-A03097
812256-F50212

Remove and destroy Bulletin 206-07, amended 04/00.
Replace with this Bulletin.
The content of this bulletin is all new.

Issue:

This Technical Bulletin has been issued to address three specific customer complaints:

- Unable to remove the gear lever from 'Park' position when depressing the brake pedal.
- The brake lights may operate without depressing the brake pedal.
- FAILSAFE is displayed in the message center and DTC P1571 is stored in the ECM..

To eliminate the customer concerns, an improved brake pedal switch assembly has been introduced on XK series vehicles from VIN number A03098 and on V8 XJ series vehicles from VIN number F05566.

The improved brake pedal switch assemblies are interchangeable with those fitted to earlier vehicles and should be replaced on any XK or V8 XJ series vehicle within the above VIN ranges on a customer complaint basis only.

Action:

In case of a customer complaint of above conditions on a 1997-2000 MY XK or 1998-2002 MY V8 XJ series vehicle within the above VIN ranges, refer to the procedures below:

XK SERIES VEHICLES

Install improved brake pedal switch only.

V8 XJ SERIES VEHICLES

In VIN range 812256 to F05565, if the vehicle is equipped with the old level brake switch, install the improved brake switch (page 4). If the improved brake light switch was already installed, install the improved brake pedal with a new brake pedal switch.

From VIN number F05566, install the improved brake pedal with a new brake pedal switch. A modified brake pedal was introduced on production from VIN number F50213.

BRAKE SWITCH INSTALLATION FOR XK VEHICLES ONLY

1. Open drivers door.
2. Switch ignition 'ON'.
3. Motor drivers seat fully rearward.
4. Switch ignition 'OFF'.

5. Open hood and fit fender protector covers.
6. Displace and remove brake booster compartment cover.

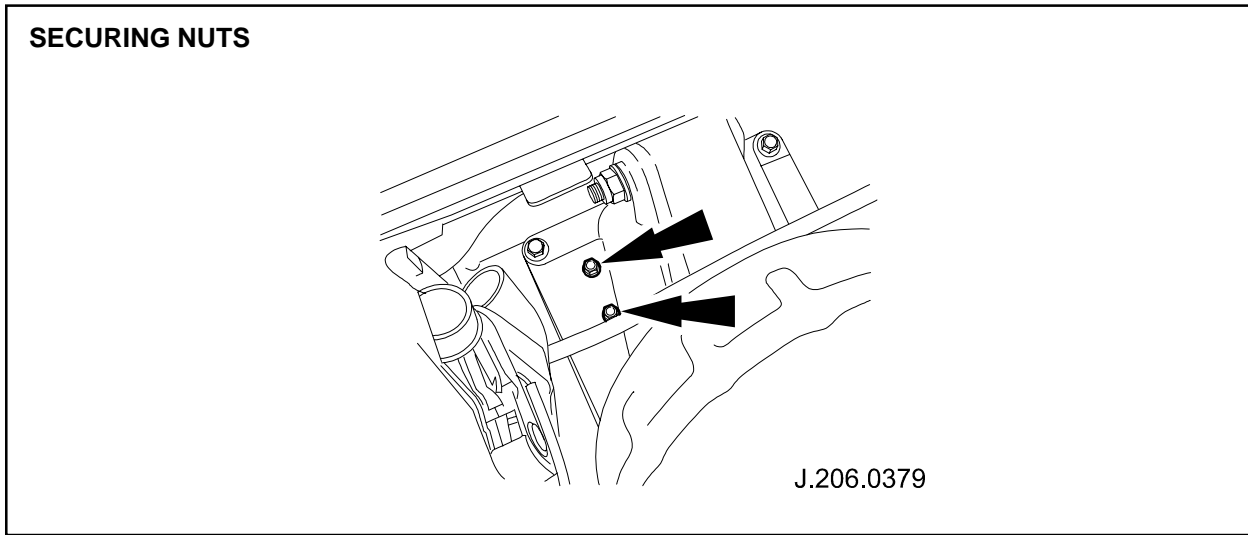

ILLUSTRATION 1

7. Remove stop light switch to brake pedal box-securing nuts (Illustration 1).
8. From inside drivers foot well.
9. Press brake pedal down to allow removal of stop-lamp switch.
10. Displace and reposition stop light switch from brake pedal box housing.
11. Release brake pedal.

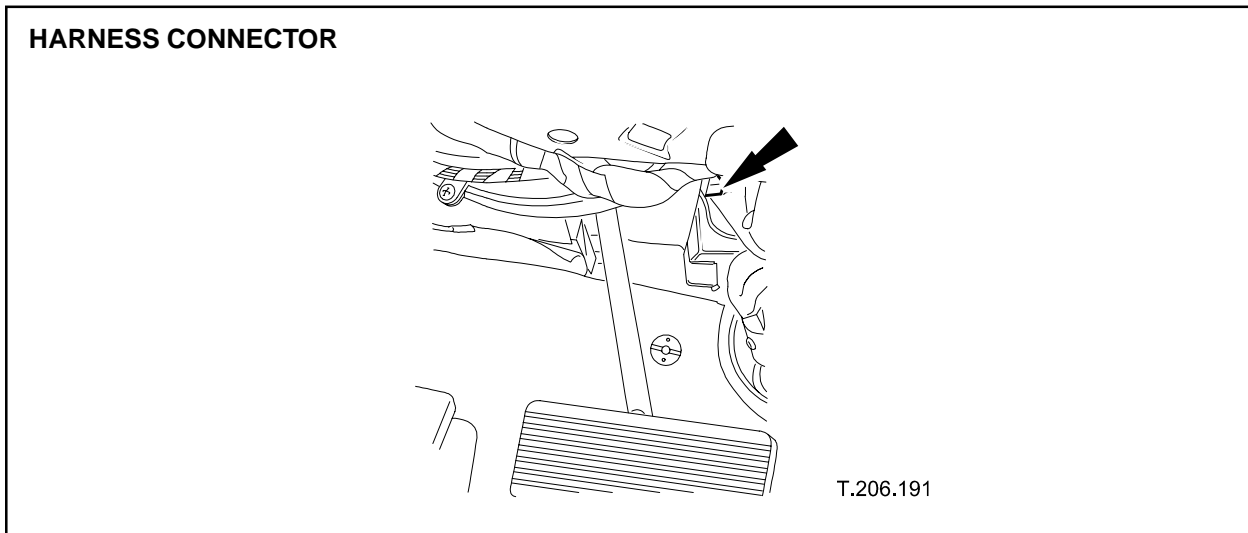
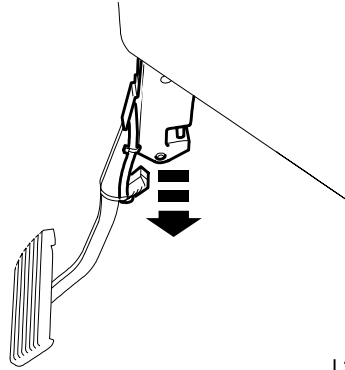

ILLUSTRATION 2

12. Disconnect stop light switch electrical harness connector (Illustration 2).

REMOVING STOP LAMP SWITCH



J.206.0381

ILLUSTRATION 3

13. Remove stop light switch and place to one side (Illustration 3).
14. Place new stop light switch to front.
15. Ensure stop light switch ratchet adjuster is fully released.
16. Install stop light switch electrical harness connector.
17. Press brake pedal down.
18. Install new stop light switch to brake pedal box.
19. Release brake pedal.

SECURING NUTS

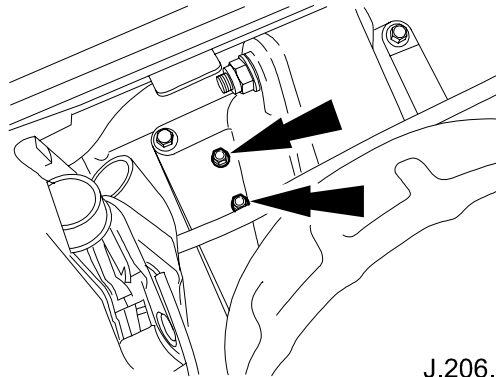

J.206.0379

ILLUSTRATION 4

20. Install and tighten stop light switch securing nuts to 3 Nm (Illustration 4).
21. Install brake booster compartment cover.
22. Remove fender protector covers and close hood.
23. Switch ignition on.
24. Check operation of stop light switch.
25. Motor drivers seat to original position.
26. Switch ignition off.
27. Close door.

BRAKE SWITCH INSTALLATION FOR V8 XJ SERIES VEHICLES ONLY

1. Open drivers door.
2. Switch ignition on.
3. Motor drivers seat fully rearward.
4. Switch ignition off.

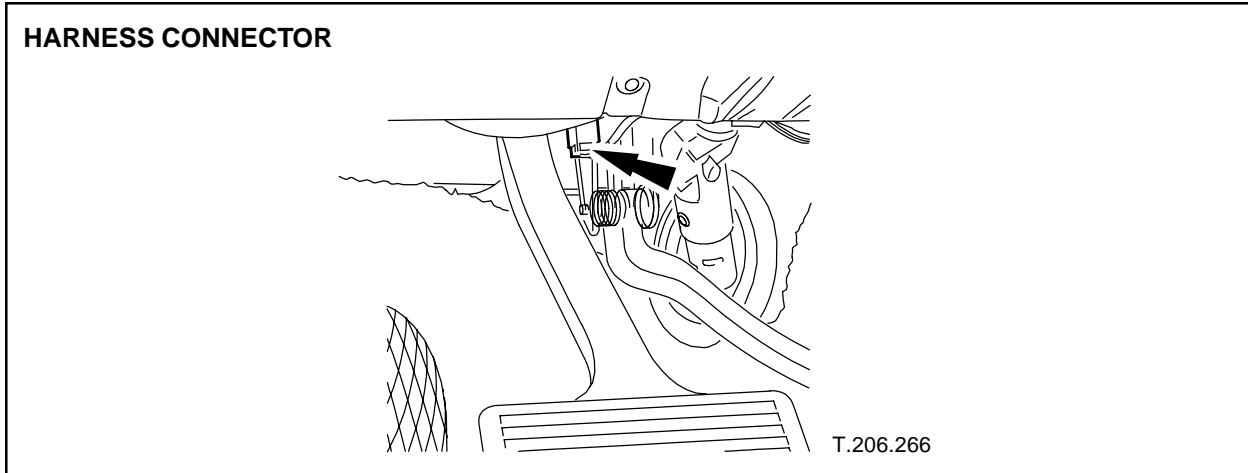

ILLUSTRATION 5

5. Disconnect stop light switch electrical harness connector (Illustration 5),

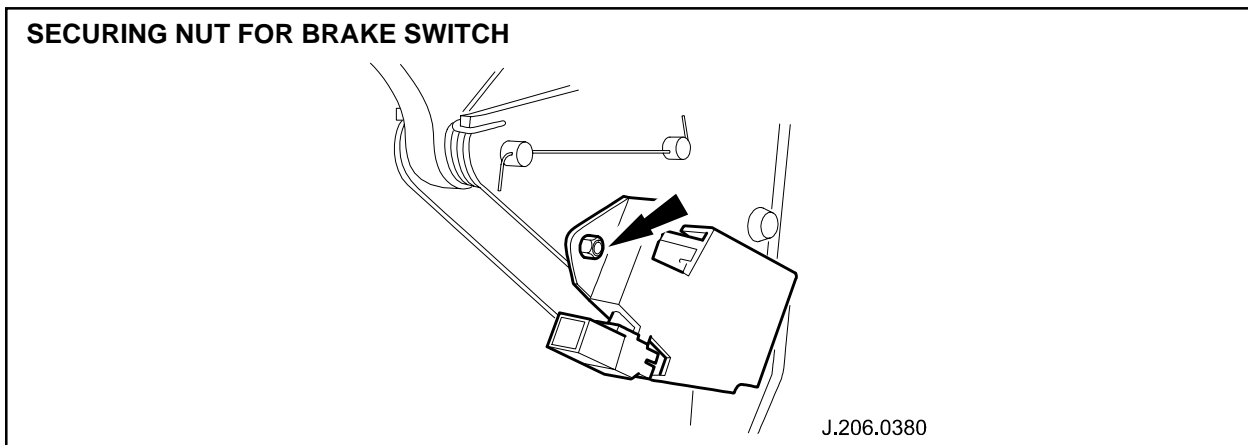

ILLUSTRATION 6

6. Undo and remove stop light switch to brake pedal box securing nut and bolt (Illustration 6).
7. Displace and remove stop lamp switch downwards. (Top is retained by open ended hole)
8. Place stop light switch aside.
9. Position new stop light switch.
10. Ensure stop light switch ratchet is fully released.
11. Install new stop light switch on brake pedal box. (Locating upper fixing)
12. Tighten stop light switch securing nut and bolt to 3 Nm (Illustration 6).

HARNESS CONNECTOR

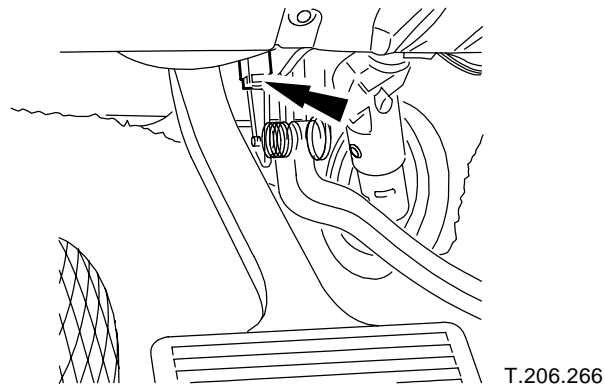

ILLUSTRATION 7

13. Connect stop light switch electrical harness connector (Illustration 7).
14. Press down brake pedal and release, brake pedal switch automatically resets on ratchet.
15. Switch ignition on.
16. Check operation of brake pedal switch.
17. Motor drivers seat to original position.
18. Switch ignition off.
19. Close door.

BRAKE PEDAL AND SWITCH INSTALLATION FOR V8 XJ SERIES VEHICLES ONLY:

Install new brake pedal and new brake pedal switch assembly (see Workshop Manual, JTIS CD ROM section: 206-06, SRO 70.35.39 for procedure to remove pedal box).

Parts Information:

<u>DESCRIPTION</u>	<u>PART NUMBER</u>	<u>QTY</u>
Brake pedal switch XK8	LJB 6420BB	1
Brake pedal switch V8 XJ Series	LNB 6420BB	1
Brake pedal - V8 XJ Series	MNE 5373BB	1
Brake pedal gasket - V8 XJ Series	MNB 5412AA	1
Brake fluid - V8 XJ Series	MNA 7829AD	1

Warranty Information:

<u>FAULT CODE</u>	<u>R.O. NUMBER</u>	<u>DESCRIPTION</u>	<u>TIME ALLOWANCE</u>
HJ BB 42	70.35.01/01	Install brake pedal and brake pedal switch - V8 XJ Series	1.7 hrs.
QN FB 42	86.65.51	Install brake pedal switch - V8 XJ and XK Series	0.2 hrs.