

Author: **timex** on 2007-12-17 at 11:21:31

(posted from: Host: exchange.juniperindustries.com IP: 68.161.239.98)

Subject: **Re: Here you go. TSB 501-33**

(429 views)

Message: I Hope this helps you out.

Tim

Body - Convertible Top Operating Slowly

501-33

DATE 8/99  
Amended 04/03

XK  
MODEL  
1997-99 MY  
XK Convertible  
VIN  
001001-037188

Slow Operation/Erratic Latching - Convertible Top - Repair Procedure  
Remove and destroy Bulletin 303-33, dated 08/99. Replace with this Bulletin. The procedure has been revised.

**Issue:**  
Some 1997-99 MY XK8 Convertibles may experience slow operation of the convertible top, or slow or erratic operation of the latch. These conditions are caused by a tendency of the Univis hydraulic fluid in the system to slowly evaporate, and in certain conditions to gel within the hydraulic system pipes and hoses. From VIN 037189, vehicles in production have been filled with an improved fluid, Pentosin CHF 11S.

The condition described above is more typical, of a vehicle used in moderate to high ambient temperatures and when the convertible top hydraulic system has not been actuated for some time.

**Action:**  
On a verified customer complaint of slow operation or erratic latching of the convertible top, check the hydraulic fluid level within the reservoir, and if low, top up using "Pentosin" fluid (Part No JLM21112) Cycle the top fully open and closed several times to see if the performance returns to normal. If the concern is still evident, then carry out the workshop procedure outlined below.  
If all other potential causes have been eliminated, it is necessary to flush the hydraulic system and change the fluid to "Pentosin" (JLM21112). This should be performed on a customer complaint basis only, on vehicles within the above VIN range.

**REPAIR PROCEDURE**  
Caution: Only use Pentosin fluid, JLM21112, for topping-up or refilling the hydraulic system on any XK series convertible. Do not use any other type of hydraulic fluid.

- Remove luggage compartment carpet.
- Remove luggage compartment front liner (See Workshop Manual, JTIS CD ROM, section: 501-05, SRO 76.19.31).
- Remove luggage compartment right hand side liner. (See Workshop Manual, JTIS CD ROM, section: 501-05, SRO 76.19.22).
- Turn ignition ON.
- Power the convertible top to full open position.
- Turn ignition OFF.
- Disconnect battery. (See Workshop Manual, JTIS CD ROM, section: 414-01).  
Note: Ensure the radio code is available before disconnecting the battery.

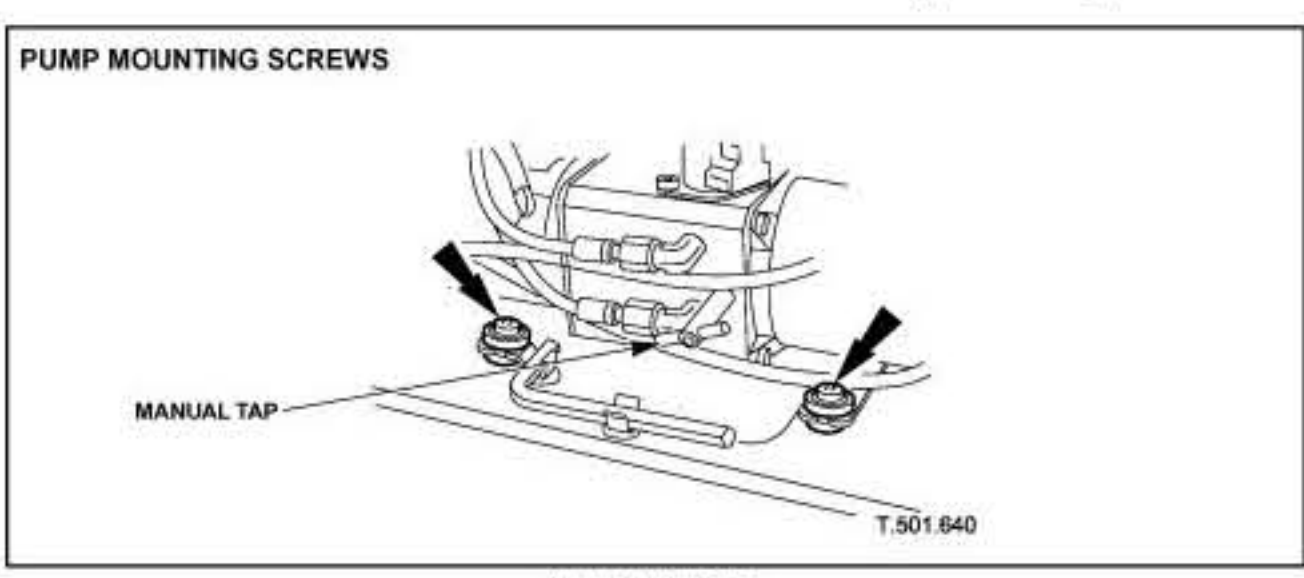

ILLUSTRATION 1

- Remove convertible top pump assembly securing screws. (Illustration 1).
- Open convertible top pump manual tap. (Approximately 3-1/4 turns).
- Remove convertible top pump reservoir filler plug.  
Caution: Cover luggage compartment floor with suitable material in case of spillage of hydraulic fluid.
- Place suitable container in trunk area.
- Reposition and invert convertible top pump assembly over container and allow fluid to drain.
- Manually raise and lower top six times to expel fluid from operating rams.
- Allow fluid to drain, reposition convertible top pump upright and clean spilled fluid from pump/reservoir.
- Close convertible top pump manual tap.

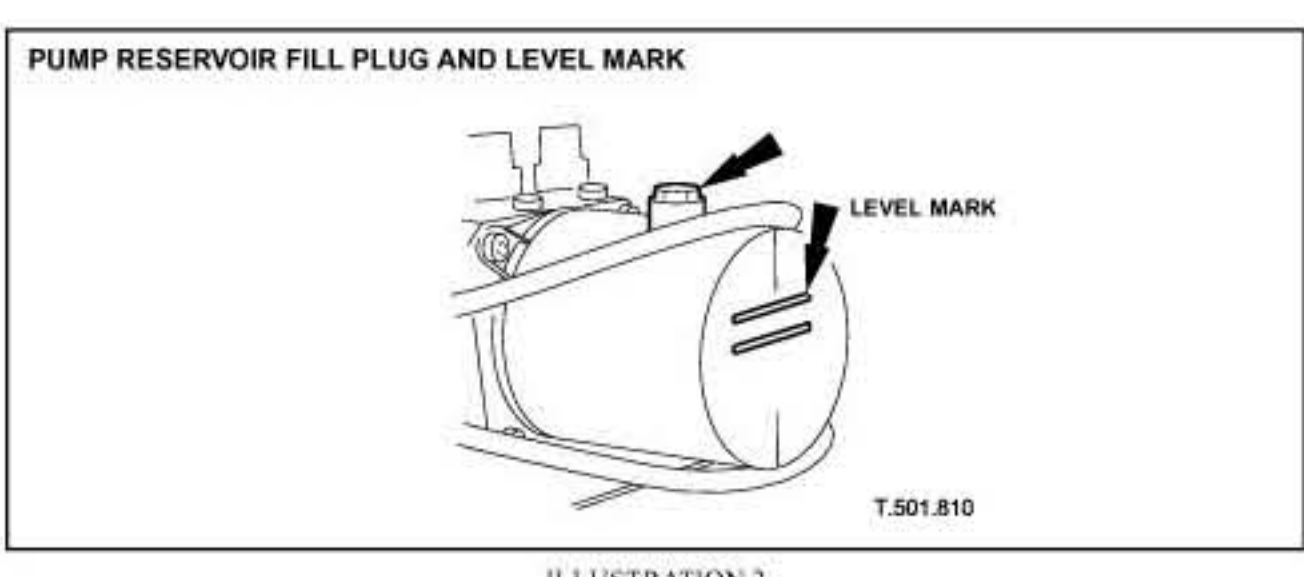

ILLUSTRATION 2

- Fill convertible top pump reservoir to upper level with Pentosin fluid. (Illustration 2)
- Remove header rail upper trim panel. (See Workshop Manual, CD ROM, section: 501-18, SRO 76.26.20).

Note: When removing illuminated sun visor, refer to SRO 76.10.48 not 76.10.47 as stated in section 501-18.

- Disconnect the harness electrical connector from the latch. Release the hydraulic pipes from the retaining clips on the A-post.
- Disconnect sun visor harness electrical connectors from their brackets on the latch bracket.  
Note: During the next operation do not remove the securing bolts from the elongated open-ended holes.
- Remove 10 bolts that secure the latch assembly to the header.
- While supporting the latch assembly, loosen the three remaining bolts in the elongated holes until the latch assembly can be displaced as these three bolts slide through the open-ended holes.
- Cut and discard the tie strap that secures the hoses. Use tape to identify the two hoses for correct connection during reassembly.
- Having protected trim and carpet with suitable material, drain container adjacent to left-hand door, disconnect hydraulic hoses, moving them towards the container to allow partial draining.
- Discard O-ring seals from hydraulic hoses; hold latch assembly over drain container, and manually actuate latch until all fluid has been expelled.
- Connect battery. (See Workshop Manual, JTIS CD ROM, section: 414-01, General Procedures).
- Turn ignition ON.
- Operate convertible top switch both ways until Pentosin fluid is expelled from both latch assembly hydraulic pipes.
- Clean any spilled fluid from convertible top latch assembly and hydraulic pipes.
- Turn ignition OFF.
- Disconnect battery. (See Workshop Manual, JTIS CD ROM, section: 414-01)
- Install and fully seat new O-rings to convertible top latch assembly hydraulic pipes, offer up latch assembly and reconnect hoses, noting tape identification markings made during removal.
- Fully tighten union nuts.
- Secure hoses to latch assembly with a new tie strap.
- Reconnect electrical harness connector to latch assembly.
- Make sure that hoses are not kinked or trapped, and engage the latch assembly to the header, starting three bolts into the elongated holes. Install and tighten all securing bolts.
- Install header rail upper trim panel. (See Workshop Manual, CD ROM, section: 501-18).
- Note: When installing illuminated sun visor refer to SRO 76.10.48 not 76.10.47 as stated in section 501-18.
- Top up convertible top pump reservoir to upper level with Pentosin fluid.
- Install but do not tighten convertible top pump reservoir filler plug.
- Connect battery. (See Workshop Manual, JTIS CD ROM, section: 414-01).
- Turn ignition ON and start engine, allowing it to idle so that full battery voltage is maintained.
- Actuate rocker switch to drive convertible top through two complete cycles of closing and opening. Check latch fully engages when convertible top is in the fully closed position.
- Turn ignition OFF.
- Reposition and invert convertible top pump assembly over container and allow fluid to drain.
- Reposition convertible top pump upright and clean spilled fluid from pump/reservoir.
- Remove container and place aside.

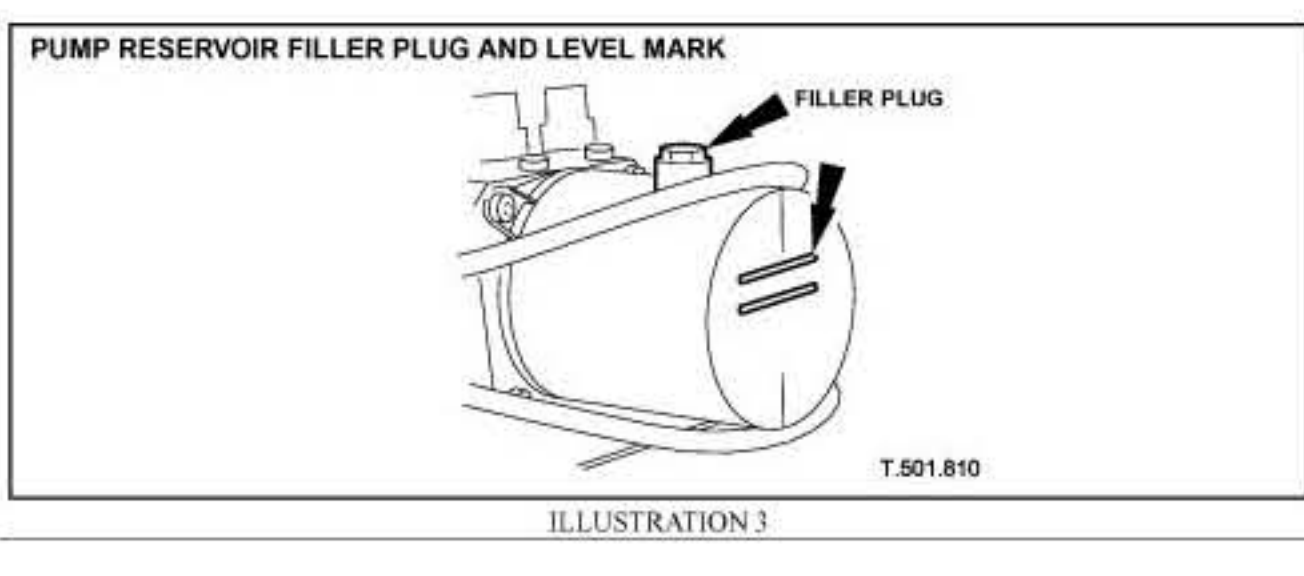

ILLUSTRATION 3

- Top up convertible top pump reservoir to upper level with Pentosin fluid. Temporarily install the reservoir filler plug. (Illustration 3).
- Turn ignition ON and start engine, allowing it to idle so that full battery voltage is maintained.
- Actuate rocker switch to drive convertible top through two complete cycles of closing and opening. Check latch fully engages when convertible top is in the fully closed position.
- Close convertible top.
- Turn ignition OFF.
- Remove reservoir filler plug. Check fluid level and if necessary top up to low level mark. Install and tighten filler plug.
- Reposition convertible top pump to mounting position.

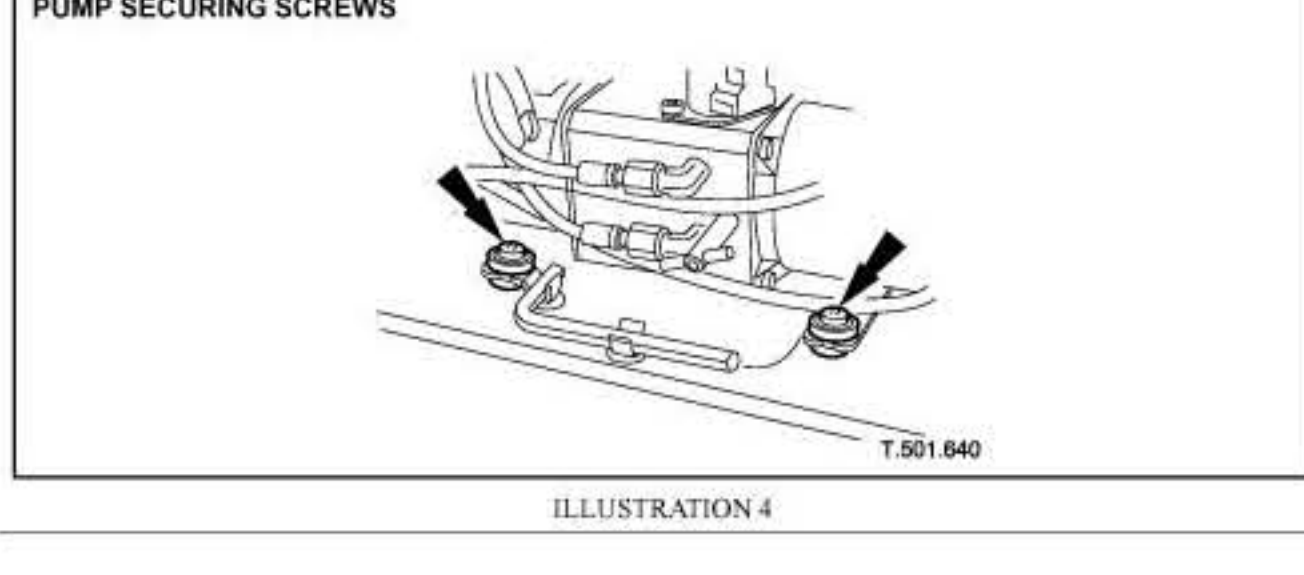

ILLUSTRATION 4

- Install and tighten convertible top pump securing screws. (Illustration 4).
- Remove the absorbent material used to contain any fluid spillage on the luggage compartment floor.
- Install luggage compartment right hand side liner. (See Workshop Manual, JTIS CD ROM, section: 501-05, SRO 76.19.22).
- Install luggage compartment front liner. (See Workshop Manual, JTIS CD ROM, section: 501-05, SRO 76.19.31).
- Install luggage compartment carpet.

DESCRIPTION	PART NUMBER	QTY
Pentosin hydraulic fluid (1 liter container)	JLM 21112	1
Tie strap	ADU 9028	1
O-ring - hose connection at convertible latch (supplied as pack of 6)	HJD 8259AA	2

Parts Information

Description	SRO	Time	Causal Part Number
Convertible top – hydraulic fluid modification	76.93.66	1.7 hrs.	JLM 21112

**The 2010 Acura TSX** Looking for a used luxury vehicle? See Acura TSX photos and specs. [www.acura.com](#)

**2010 Lexus GX** Compare the GX to its Competition & Discover the Benefits of the GX. [www.Lexus.com/GX/Compare](#)

**Ask a Jaguar Mechanic Now** 6 Jaguar Mechanics Are Online! Ask a Question, Get an Answer ASAP. [Jaguar\\_JustAnswer.com](#)

Ads by Google

The Jaguar XK8/XKR Forum | Message Posts:

- [Jag XK8 new owner - Roc](#) 2007-09-18 15:13:45 (569 views) (5050 thread views)
  - [If it were my car...](#) - **Charlie Leonard** e43 2007-09-19 21:49:32 (440 views)
    - [Re: If it were my car...](#) - **Roc** 2007-09-20 11:13:59 (341 views)
    - [Re: If it were my car... - Charlie Leonard](#) e43 2007-09-20 15:16:50 (289 views)
    - [Re: If it were my car...](#) - **Yacht Sales** 2007-09-20 13:31:48 (281 views)
  - [Re: Jag XK8 new owner - timex](#) e30 2007-09-18 15:47:33 (374 views)
    - [Re: Jag XK8 new owner - Roc](#) 2007-09-18 16:07:42 (307 views)
    - [Re: Jag XK8 new owner - timex](#) e30 2007-09-18 16:59:14 (341 views)
      - [Re: 1999 XK8 & 2002 XKR TSB's - timex](#) e30 2007-09-18 19:30:39 (936 views)
        - [Re: 1999 XK8 & 2002 XKR TSB's - Roc](#) 2007-09-20 11:17:53 (268 views)
          - [Re: 1997 XKR/XKR Recalls and TSBs \(url\) - Harley D.](#) 2007-09-21 14:31:40 (386 views)
            - [Re: 1997 XKR/XKR Recalls and TSBs](#) - **Roc** 2007-09-25 14:34:56 (189 views)
              - [Re: Nickname - Harley D.](#) 2007-09-26 06:45:32 (149 views)
              - [Re: 1997 XKR/XKR Recalls and TSBs](#) - **Roc** 2007-09-22 12:02:28 (192 views)
              - [Re: 1997 XKR/XKR Recalls and TSBs](#) - **Charlie Leonard** e43 2007-09-21 17:40:18 (179 views)
                - [Re: Complete TSB Descriptive Text - Harley D.](#) 2007-09-21 19:57:51 (246 views)
                  - [Re: Complete TSB Descriptive Text - Charlie Leonard](#) e43 2007-09-22 00:42:09 (193 views)
                  - [Re: Complete TSB Descriptive Text - Onca 3](#) e33 2007-09-21 20:47:21 (178 views)
                    - [Re: Infotraxx Info + TSB Article from Edmunds \(url\) - Harley D.](#) 2007-09-22 01:28:42 (268 views)
        - [Re: 1999 XK8 & 2002 XKR TSB's - timex](#) e30 2007-09-21 07:05:47 (215 views)
          - [Re: 1999 XK8 & 2002 XKR TSB's - Roc](#) 2007-09-21 09:15:26 (207 views)
            - [Re: 1999 XK8 TSB's - cooljag](#) 2007-12-15 14:31:22 (156 views)
              - [Re: Here you go. TSB 501-33 - timex](#) e30 2007-12-17 11:21:31 (429 views)
                - [Re: Question Re:TSB 501-33 - Moonshiner](#) e27 2007-12-18 14:42:44 (135 views)
                - [Re: Here you go. TSB 501-33 - cooljag](#) 2007-12-17 20:56:01 (180 views)
                  - [Re: Here you go. TSB 501-33 - cooljag](#) 2007-12-23 19:19:20 (137 views)