



XK8

DATE 02/00
Amended 07/00

501-39

SERVICE

TECHNICAL BULLETIN

Airbag Deactivation Switch - Installation Instructions - USA Vehicles

MODEL 1997 MY-ON
XK8 Range
VIN 001001-ON

Remove and destroy Bulletin 501-39, dated 02/00.
Replace with this Bulletin.
Revisions are marked with a bar and in **bold text**.

Issue

An airbag deactivation switch kit may be installed, **at owner expense**, on the 1997 MY-on **XK8 Range** vehicles to allow the owner/driver to control whether the airbag(s), driver, front passenger or both, are active or inactive. **This is a customer paid modification.**

Note: This kit is a protected, controlled use item. The vehicle owner **must** have permission from Jaguar North America and an N.H.T.S.A. waiver permitting use of the kit.

Note: Prior to installation the airbag deactivation switch kit, determine whether the vehicle has previously been equipped with a shunt deactivation kit in the airbag harness connector. If so, order a new set of sun visors in the relevant color. When the deactivation switch kit fitting takes place, remove the shunt kit and change the sun visors to the new set, with the normal instructions printed on the reverse side label. Return the shunt, with VIN of car to the Product Legislation and Compliance Department at Mahwah.

Action:

INSTALLATION INSTRUCTIONS

- Prior to disconnecting the battery, move the transmission selector lever to Neutral 'N' or Reverse 'R'.
- Disconnect both battery terminals, negative first, and stow safely to avoid any possible arcing.
- Before proceeding with the fitting procedure, wait a minimum of 1 minute to allow full discharge of components.
- Remove the J-gate surround, Illustration. 1, by releasing the four clips with a suitable tool.

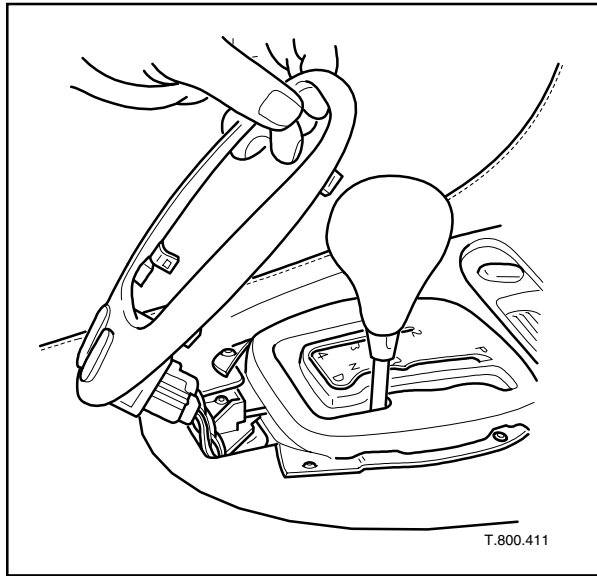

Illustration 1

- Disconnect the switches on the underside, rear of the J-gate surround, Illustration 2, and release the securing clip.

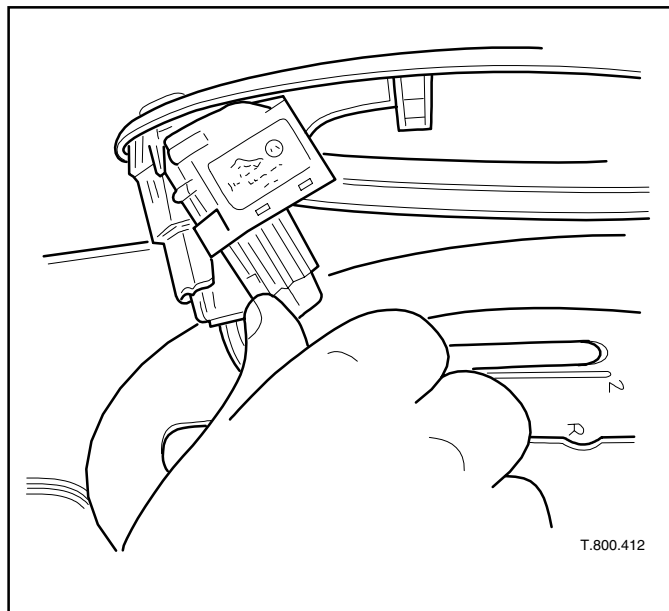

Illustration 2

- Remove the four screws securing the wood veneer, Illustration 3.

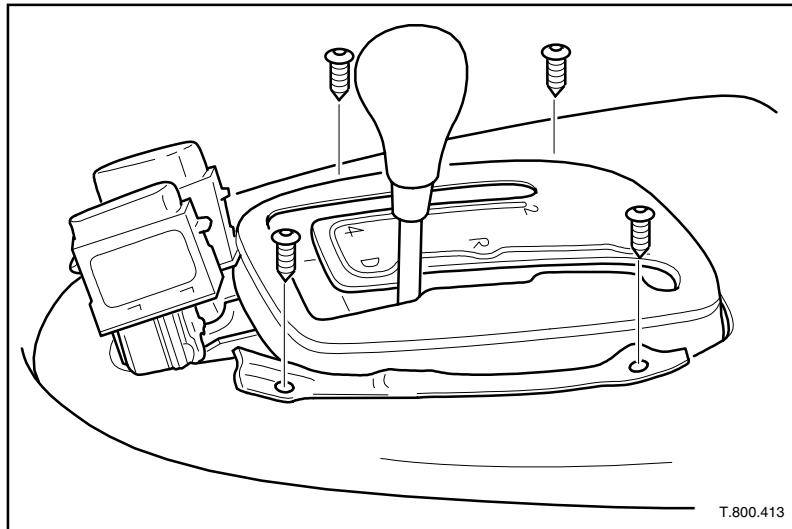

Illustration 3

- Lift the veneer and remove the two spacer washers, arrowed, Illustration 4.

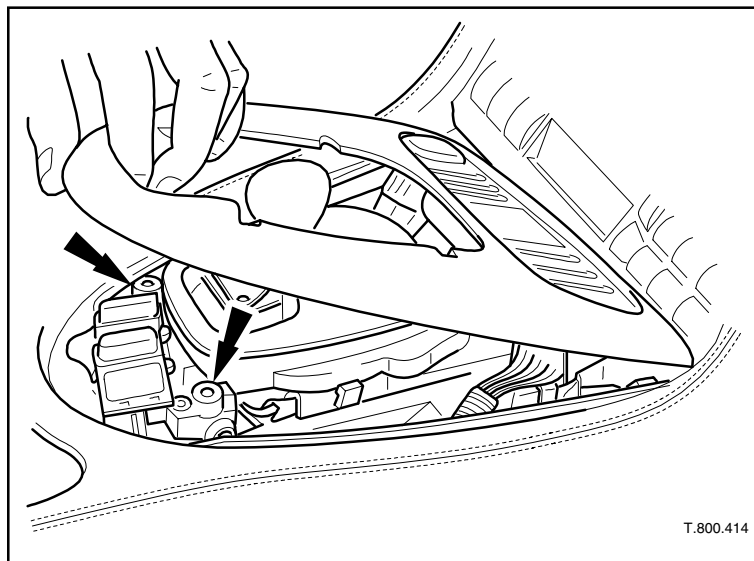

Illustration 4

Convertible only: Disconnect the convertible top for switch connector, Illustration 5.

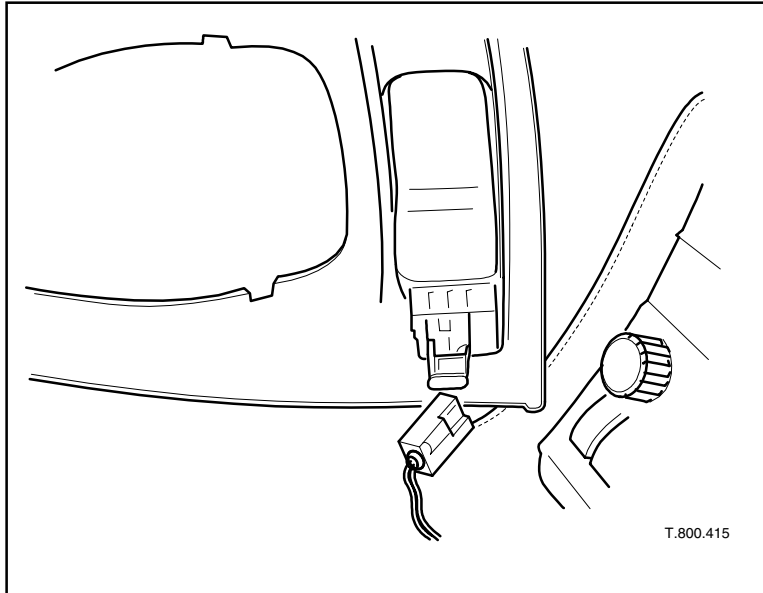

Illustration 5

- Hold the veneer panel firmly, taking care not to crack or damage the veneer.
- Apply gentle pressure to the front edge and spring slightly open to release the coin/trinket tray assembly, Illustration 6.

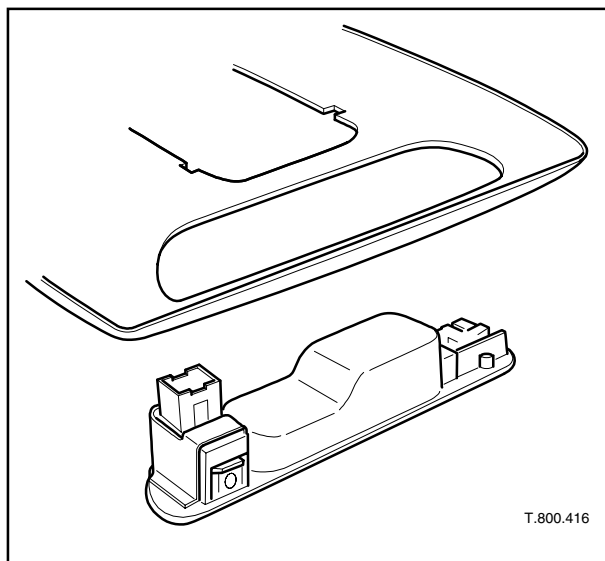

Illustration 6

- On the underside of the coin/trinket tray assembly, remove the metal clip, arrowed, Illustration 7, securing the hood switch.

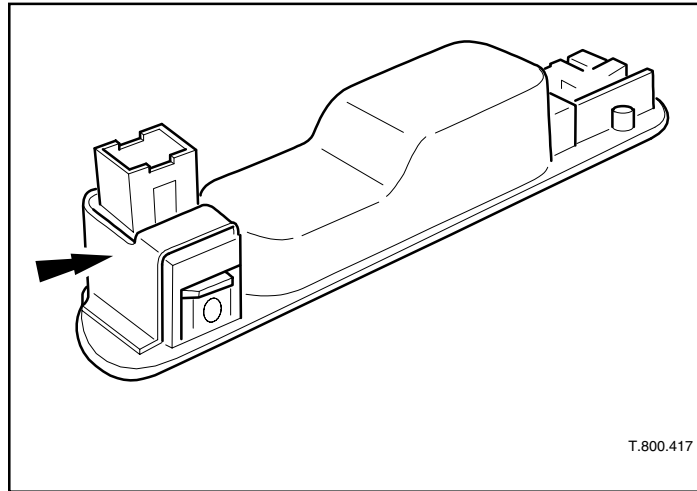

Illustration 7

- Remove the convertible top switch from the coin/trinket tray, Illustration 8, and discard the old trinket tray.

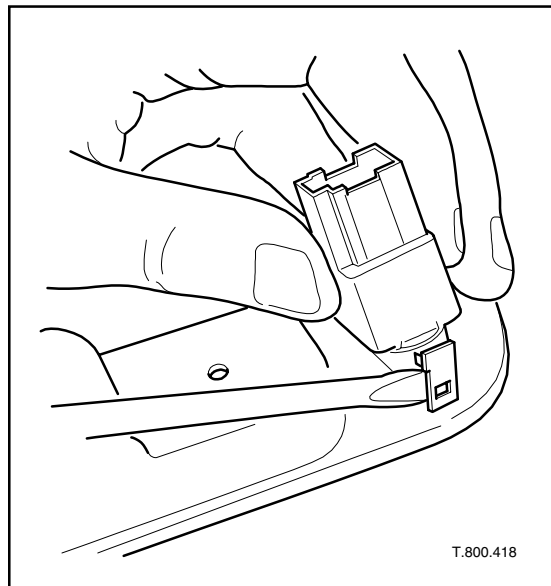

Illustration 8

Refer to the latest JTIS disc (service manual), to carry out the following operations:

- Remove the glove box assembly.
- Remove the 'A' post finisher.
- Insert the airbag deactivation switch into the new coin tray, supplied in the kit, Illustration 9.

Note: The switch is supplied with a foam gasket. Ensure this is fitted between the underside of the switch and the face of the coin tray.

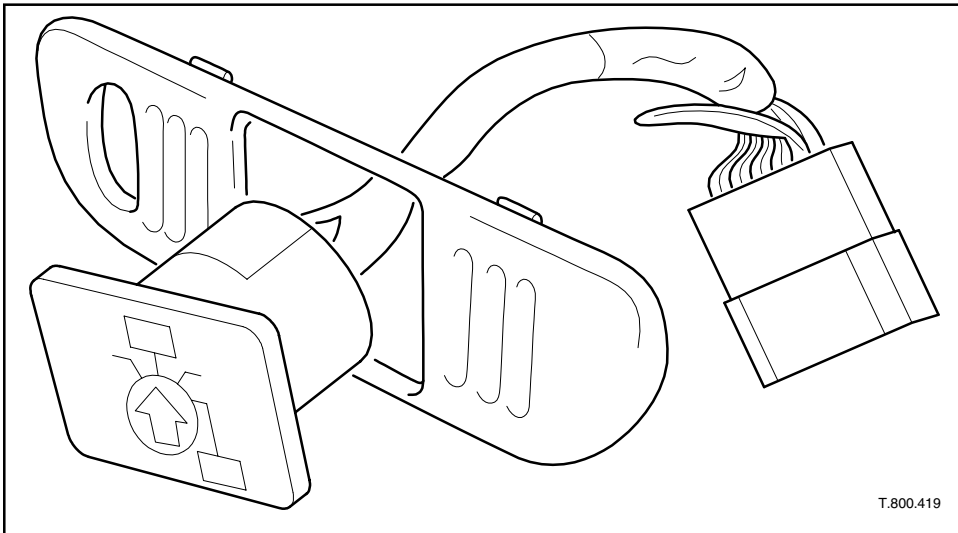

Illustration 9

- Locate the switch lugs into the coin tray. Fully secure the switch by pushing the 'star' fixing washers fully down over the lugs, Illustration 10.

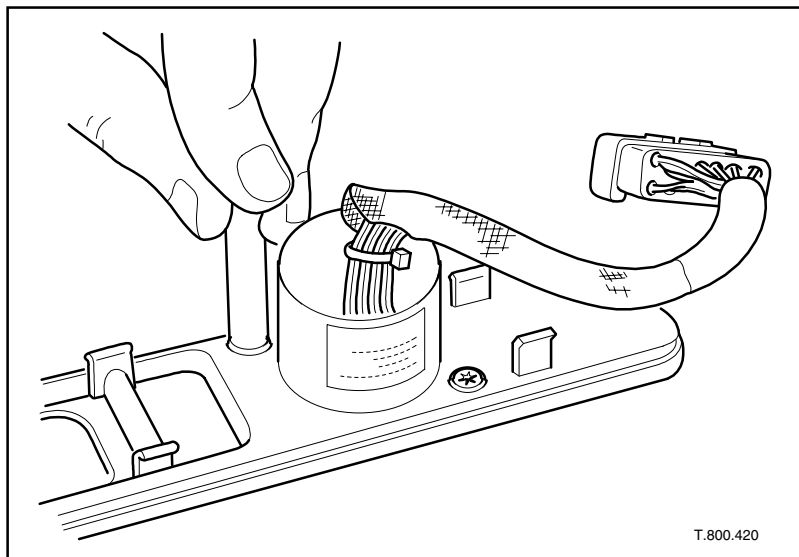

Illustration 10

Convertible only: Refit the convertible top for switch.

- Install the coin tray assembly to the veneer panel, Fig. 11, by clipping in the rear first, then gently easing the front to clip fully in.

Note: The switch body will be a close fit to the veneer aperture.

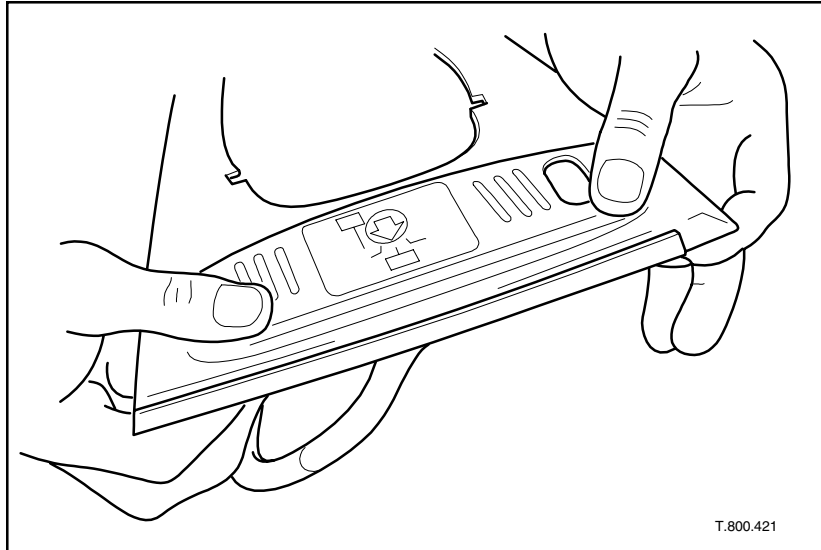

Illustration 11

- Provisionally fit the veneer panel assembly in place.
- Check that the airbag deactivation switch does not interfere with the fixing bolt for the reverse blocker solenoid, arrowed, Illustration 12.

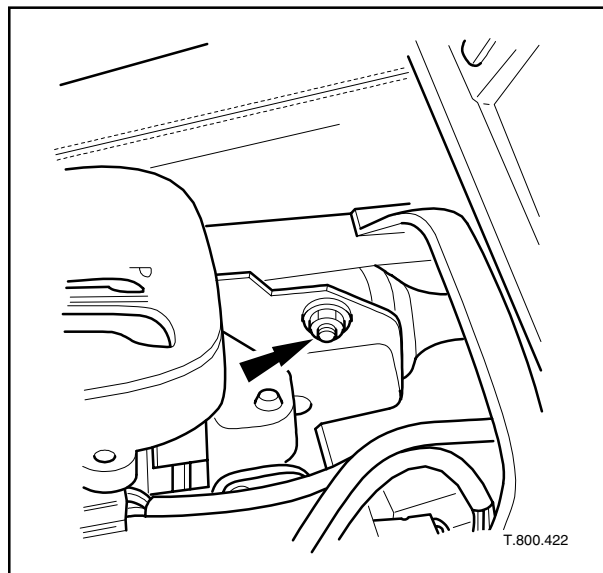

Illustration 12

- If interference does exist, relieve by carefully filing back the solenoid fixing bolt.

Note: Ensure all harnesses, trim panels and components are protected from damage and any filings/debris are thoroughly cleaned from the surrounding area.

Refer to the latest JTIS disc (service manual), to carry out the following operations:

- Remove the center tunnel/cubby box trim panel assembly, ensuring the cigar lighter is disconnected.
- Remove the ICE (in-car entertainment), panel assembly. Remove the underscuttle panel with the glove box.
- Position the deactivation switch harness, arrowed, Fig. 13, in the center tunnel area.

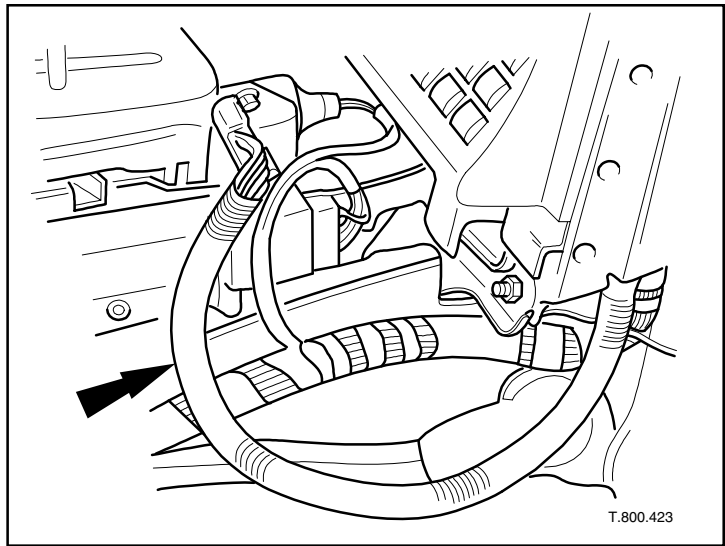

Illustration 13

- Route the harness across the center tunnel, behind the glove box, Illustration 14 and cable tie to the existing harness, just beyond the 'vee' joint.

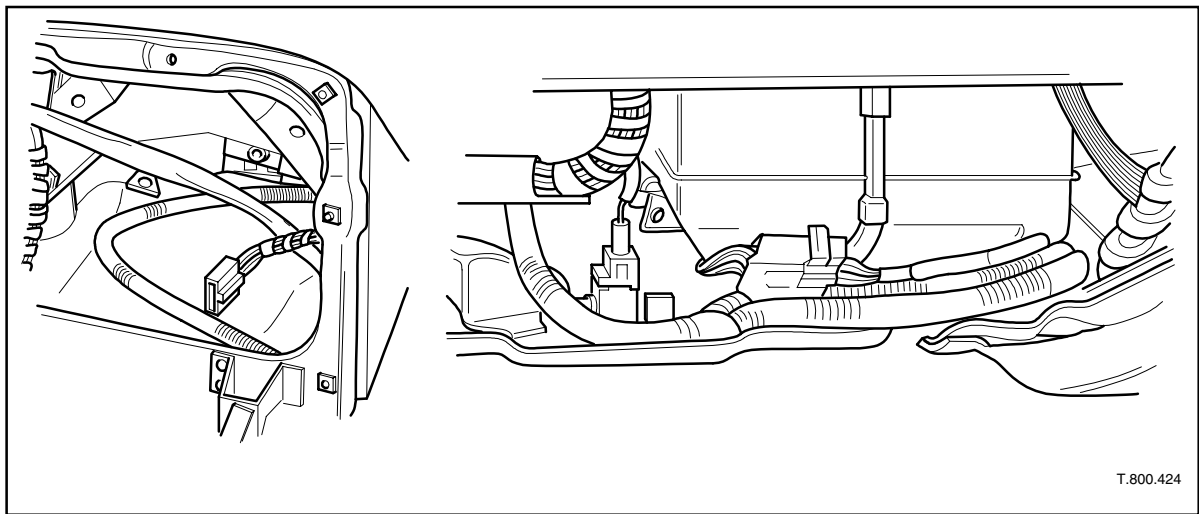

Illustration 14

- Disconnect the forward, light gray, connector, on the blue, restraints control module.
Replace with the light gray connector on the airbag switch harness, arrowed, Illustration 15.
Ensure a good connection is made, indicated by a positive 'click'.

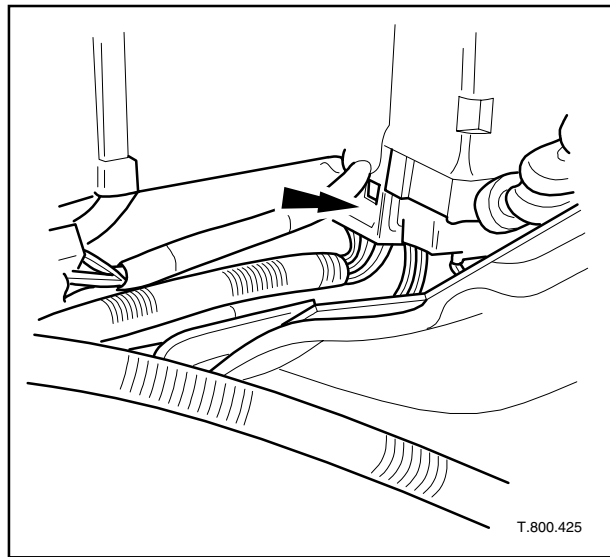

Illustration 15

- Connect the, female, light gray connector, previously removed, to the male connector on the airbag switch harness, Illustration 16. Ensure a good connection is made, indicated by a positive 'click'.

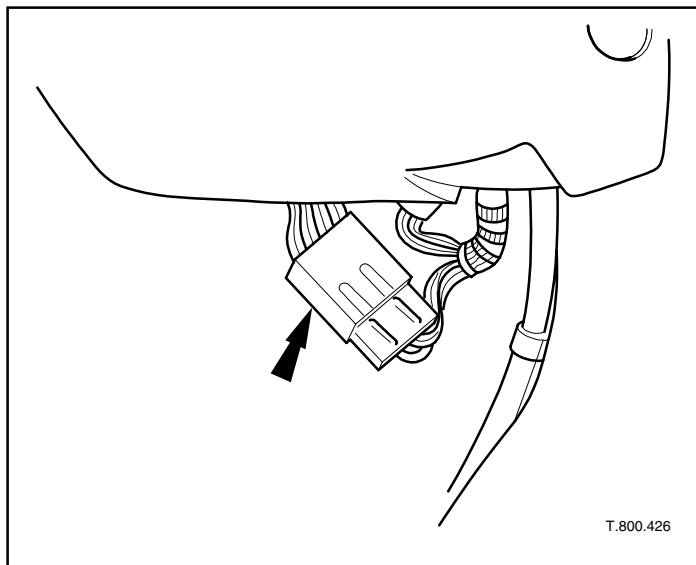

Illustration 16

- Ensure the harness is positioned and secured to avoid chafing or rattle condition. Secure both branches of the harness with cable ties, arrowed, Illustration 17.
- Illustration 17, 'A' shows center console area. Illustration 17, 'B' shows right side under dashboard area.

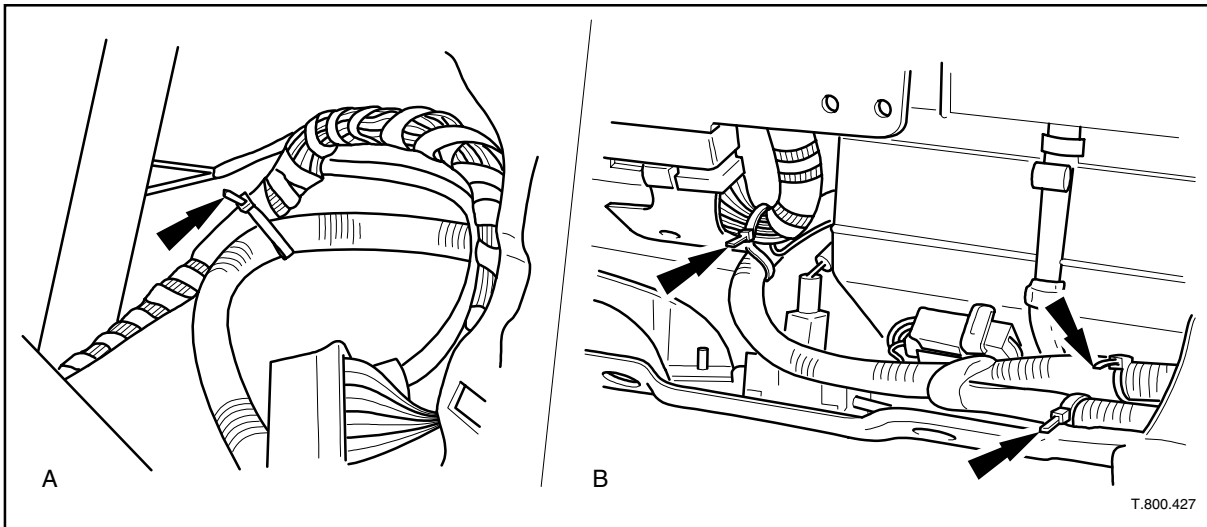

Illustration 17

Refer to the latest JTIS disc (service manual), to carry out the following operations:

- Reinstall the glove box.
- Reinstall the 'A' post finisher.
- Reinstall the center tunnel/cubby box trim panel assembly, ensuring the cigar lighter is re-connected.
- Reinstall the ICE (in-car entertainment), panel assembly.
- On the J-gate wood veneer, connect the airbag harness to the airbag deactivation switch unit, Illustration 18.

Convertible only: Ensure the convertible top switch is reconnected.

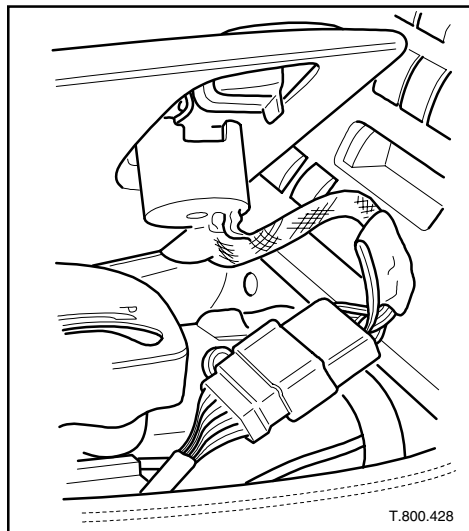

Illustration 18

- Position the connector neatly at the side of the center tunnel, Illustration 19.

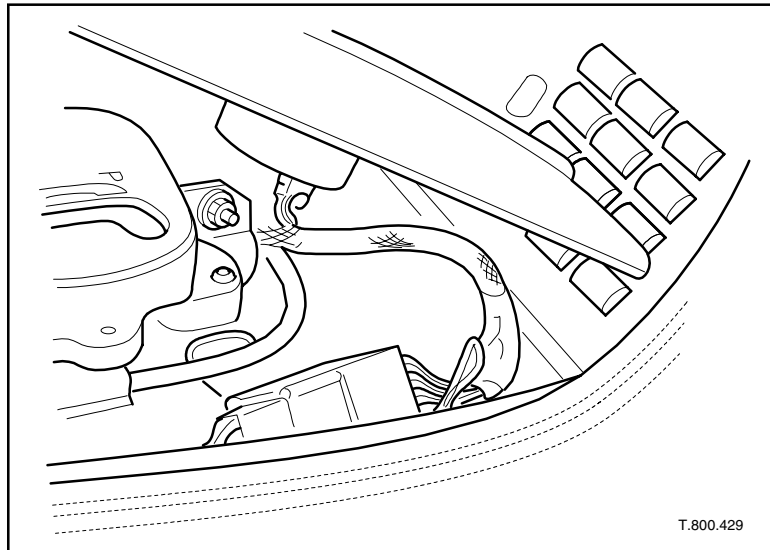

Illustration 19

- Reinstall the wood veneer, ensuring there is no foul condition or trapped wires.
- Reinstall the switches to the J-gate surround and refit the surround.
- Reconnect the battery and program the radio code.

FUNCTIONAL CHECK

- Sitting well back from the steering wheel, ensure no objects are between the airbag module and driver.
- Insert the ignition key and switch 'on' the ignition.
- Wait for the airbag warning lamp on the instrument panel to go 'off' and stay 'off'.
- Ensure neither lamp on the airbag switch panel is 'on'.
- Switch the ignition 'off'.
- Use the ignition key to turn the deactivation switch and check all positions (**where applicable within switch variant**), as follows:
 1. **Driver airbag 'off'**. With the ignition 'on', the airbag warning lamp on the instrument panel will extinguish after approx. 4 to 5 seconds. On the airbag deactivation switch, LH (driver) lamp stays 'on'.
 2. **Airbags 'on'**. With the ignition 'on', the airbag warning lamp on the instrument panel will extinguish after approx. 4 to 5 seconds. On the airbag deactivation switch, all lamps stay 'off'.
 3. **Passenger airbag 'off'**. With the ignition 'on', the airbag warning lamp on the instrument panel will extinguish after approx. 4 to 5 seconds. On the airbag deactivation switch, RH (passenger) lamp stays 'on'.

4. **Airbags ‘off’.** With the ignition ‘on’, the airbag warning lamp on the instrument panel will extinguish after approx. 4 to 5 seconds. On the airbag deactivation switch, both lamps (driver and passenger) stay ‘on’.
 - Finally, return the switch to **Airbags ‘on’** position.
 - After completion of fit and functional check, ensure the appropriate language driver instruction supplement, is inserted in the vehicle driver’s handbook.
 - **Explain the operation of the switch to the customer.**
 - Supplement publication numbers are as follows:
 - JTP 641-English.
 - JTP 642-French.
 - JTP 643-Spanish.
5. Complete the NHTSA form indicating you have added switch to car and mail to NHTSA.

Parts Information:

Note: The Jaguar Compliance and Legislation Department must be contacted to place an order for a deactivation kit.

<u>DESCRIPTION</u>	<u>PART NUMBER</u>	<u>QTY</u>
XK8 Coupe		
Airbag deactivation switch - driver’s airbag only	JLM 20979	1
Airbag deactivation switch - pass. airbag only	JLM 20980	1
Airbag deactivation switch - both airbags	JLM 20981	1
XK8 Convertible		
Airbag deactivation switch - driver’s airbag only	JLM 20982	1
Airbag deactivation switch - pass. airbag only	JLM 20983	1
Airbag deactivation switch - both airbags	JLM 20984	1

Recommended Installation Time:

<u>DESCRIPTION</u>	<u>TIME ALLOWANCE</u>
Install deactivation switch	1.35 hrs.